

ProtoAir FPA-W44

For interfacing with the following AERCO products:

- AM Series
- C-More
- Modulex
- ECS/SmartPlate
- BMS/BMSII/ACS

For interfacing with the following Building Automation Systems:

- BACnet MS/TP
- BACnet IP
- Modbus TCP/IP
- Modbus RTU
- Metasys N2

This user manual applies only to ProtoAir Model FPA-W44 (P/N 69281-3).



Disclaimer

The information contained in this manual is subject to change without notice from AERCO International, Inc. AERCO makes no warranty of any kind with respect to this material, including, but not limited to, implied warranties of merchantability and fitness for a particular application. Some states do not allow the exclusion or limitation of incidental or consequential damages, so the above limitation may not apply. AERCO is not liable for errors appearing in this manual, not for incidental or consequential damages occurring in connection with the furnishing, performance, or use of these materials.

Heating and Hot Water Solutions

AERCO International, Inc. • 100 Oritani Drive • Blauvelt, NY 10913
USA: T: (845) 580-8000 • Toll Free: (800) 526-0288 • AERCO.com
Technical Support • (800) 526-0288 • Mon-Fri, 8 am - 5 pm EST
© 2026 AERCO

Contents

Quick Start Guide	5
1. Introduction	6
1.1. ProtoAir Gateway.....	6
1.2. Methods of Configuration.....	7
2. Setup for ProtoAir	8
2.1. Record Identification Data.....	8
2.2. Point Count Capacity and Registers per Device.....	8
2.3. Configuring Device Communications.....	8
2.3.1. Confirm the Device and ProtoAir COM Settings Match.....	8
2.3.2. Set Node-ID for Any Device Attached to the ProtoAir.....	8
2.4. Attaching the Wi-Fi Antenna.....	9
2.5. WATTS Device Connections to ProtoAir Device Port R1.....	9
2.6. Wiring Field Port R2 to BAS RS-485 Serial Network.....	10
2.7. Bias Resistors.....	10
2.8. Termination Resistor.....	11
3. BACnet IP or Modbus TCP/IP: Change The ProtoAir IP Address	12
3.1. Connect the PC to ProtoAir via the Ethernet Port.....	12
3.2. BACnet IP and Modbus TCP/IP: Setting IP Address for Field Network.....	13
4. POWER UP THE GATEWAY	15
5. Connect the PC to the Gateway	16
5.1. Connecting to the Gateway via Ethernet.....	16
5.1.1. Changing the Subnet of the Connected PC.....	16
5.2. Connecting to the Gateway over Wi-Fi Access Point.....	16
5.3. Navigate to the Login Page.....	17
6. Setup Web Server Security	18
6.1. Login to the FieldServer.....	18
6.2. Select the Security Mode.....	19
6.2.1. HTTPS with Own Trusted TLS Certificate.....	20
6.2.2. HTTPS w/ Default Untrusted Self-Signed TLS Certificate or Built-in Payload Encryption.....	20
7. Configure the ProtoAir	21
7.1. Select Field Protocol and Set Configuration Parameters.....	21
7.2. Configure Devices Connected to the Gateway.....	22
7.2.1. Use Discovery Mode.....	22
7.2.2. Setting Active Profiles.....	23
7.3. Verify Device Communications.....	24
7.4. BACnet: Setting Node_Offset to Assign Specific Device Instances.....	24
7.5. How to Start the Installation Over: Clearing Profiles.....	25
8. Setup Network	26
8.1. Using FS-GUI to Input Network Settings.....	26
8.2. Change the ProtoAir IP Address.....	27
8.2.1. Routing Settings.....	27
8.2.2. Ethernet 1.....	27
8.2.3. Wi-Fi Client Settings.....	28
8.2.4. Wi-Fi Access Point Settings.....	29

9. Troubleshooting	31
9.1. Lost or Incorrect IP Address.....	31
9.2. Viewing Diagnostic Information.....	31
9.3. Checking Wiring and Settings	32
9.4. LED Functions.....	32
9.5. Taking a FieldServer Diagnostic Capture	33
9.6. Wi-Fi Signal Strength.....	34
9.7. Factory Reset Instructions.....	34
9.8. Internet Browser Software Support.....	34
10. Additional Information	35
10.1.Update Firmware	35
10.2.BACnet: Setting Network_Number for More Than One ProtoAir on the Subnet	35
10.3.Mounting.....	35
10.4.Certification.....	36
10.5.Physical Dimensions.....	36
10.6.Change Web Server Security Settings After Initial Setup	37
10.6.1. Change Security Mode.....	37
10.6.2. Edit the Certificate Loaded onto the FieldServer.....	38
10.7.Change User Management Settings	38
10.7.1. Create Users.....	39
10.7.2. Edit Users	40
10.7.3. Delete Users.....	41
10.7.4. Change FieldServer Password.....	41
11. Vendor Information – WATTS	42
11.1.AERCO/WATTS Equipment Points Mapping	42
11.1.1. AERCO C-More & ACS/BMS II/BMS Point Definitions.....	42
11.1.2. AERCO Electronic Control System (ECS) Point Definitions.....	45
11.1.3. Standalone SmartPlate EV Points.....	45
11.1.4. AERCO (Modulex) BCM Point Definitions.....	45
11.1.5. WHM and On-Board BST Point Definitions	47
11.1.6. AM Series Point Definitions.....	50
11.2.AERCO Equipment Point Mappings.....	53
11.2.1. AM Mngr Modbus RTU Mappings to BACnet MS/TP, BACnet IP, Metasys N2, Modbus TCP/IP and LonWorks.....	53
11.2.2. AM Dep Modbus RTU Mappings to BACnet MS/TP, BACnet IP, Metasys N2, Modbus TCP/IP and LonWorks	57
11.2.3. C-More Modbus RTU Mappings to BACnet MS/TP, BACnet IP, Metasys N2, Modbus TCP/IP and LonWorks	59
11.2.4. Modulex Modbus RTU Mappings to BACnet MS/TP, BACnet IP, Metasys N2, Modbus TCP/IP and LonWorks.....	60
11.2.5. ECS/SP Modbus RTU Mappings to BACnet MS/TP, BACnet IP, Metasys N2, Modbus TCP/IP and LonWorks	61
11.2.6. ACS/BMSII/BMS Modbus RTU Mappings to BACnet MS/TP, BACnet IP, Metasys N2, Modbus TCP/IP and LonWorks	61
11.2.7. MFC LMV5 Points	64
11.2.8. MFC RWF55 Points.....	68
11.2.9. Standalone SmartPlate EV Points.....	71
11.3.Sixteen C-More/Edge Boilers/Heaters and BST/WHM Master.....	72
11.4.C-More/Edge Status and Fault Messages	87
11.5.Conversion Equations For Temperature Variables.....	91
11.6.BCM and BMM Fault Codes For Modulex E8 Controller.....	92

- 11.6.1. BCM and BMM Fault Code Conversion Table 92
- 11.6.2. BMM Fault Code Table 92
- 11.6.3. BCM Fault Code Table..... 95
- 11.7.AM Error, State and Status Tables 96
 - 11.7.1. AM Lockout Error Codes Table..... 96
 - 11.7.2. AM Blocking Error Codes Table..... 97
 - 11.7.3. AM State Parameters Table 98
 - 11.7.4. AM Status Parameters Table 98
- 12. Specifications..... 99**
 - 12.1.Compliance with EN IEC 62368-1 99
 - 12.2.Warnings for FCC and IC Waste Disposal 100

QUICK START GUIDE

1. Methods of Configuration (Section 1.2):
 - **Auto-Discovery:** See the table of devices that support automatic configuration.
 - **Web Configurator:** For devices that cannot be automatically configured, use a web browser to access the Web Configurator page.
2. Record the information about the unit (Section 2.1).
3. Check that the ProtoAir and customer device COM settings match (Section 2.3).
4. **If connecting to Watts equipment:**
Connect the ProtoAir's 3-pin RS-485 "R1" device port to the RS-485 or RS-232 network of the WATTS devices. (Section 2.5)
5. **If connecting to a Building Automation System (BAS) using a serial field protocol:**
Connect the ProtoAir 3-pin RS-485 "R2" field port to the BAS RS-485 port (Section 2.6).
6. Connect power to the ProtoAir 3-pin black power port. **CAUTION:** Connect power to the black port only else damage could result to the unit (Section 3).
7. Connect a Building Automation System (BAS) doing Internet Protocol (BACnet IP or Modbus TCP) or a PC to the ProtoAir via an Ethernet cable, or connect the PC or Cell Phone to the ProtoAir's Wi-Fi Access Point (Section 4).
8. Set up the Web Server Security and login via a web browser (Section 5).
9. Use a web browser to access the ProtoAir Web Configurator page to set configuration parameters and setup connected devices using one of the methods below:
 - **Discover Devices Automatically** (Section 6.2.1): Click the Discovery Mode button at the bottom of the screen. It may take up to 10 minutes for all the devices to be discovered and the configuration file to be built.
 - **Select Devices Manually** (Section 6.2.2): Select the profiles of the devices attached to the ProtoAir and enter any necessary device information. Once the devices are selected, the ProtoAir automatically builds and loads the appropriate configuration.
10. Ethernet Network (Section 7): If using an Ethernet field protocol, use a web browser to access the ProtoAir Web Configurator page to change the IP Address.

1. INTRODUCTION

1.1. ProtoAir Gateway

The ProtoAir wireless gateway is an external, high performance building automation multi-protocol gateway that is preconfigured to automatically communicate between WATTS devices (hereafter simply called “device”) connected to the ProtoAir and automatically configures them for BACnet IP, BACnet MS/TP, Modbus TCP/IP, Modbus RTU, and Metasys N2.

It is not necessary to download any configuration files to support the required applications. The ProtoAir is pre-loaded with tested profiles/configurations for the supported devices.

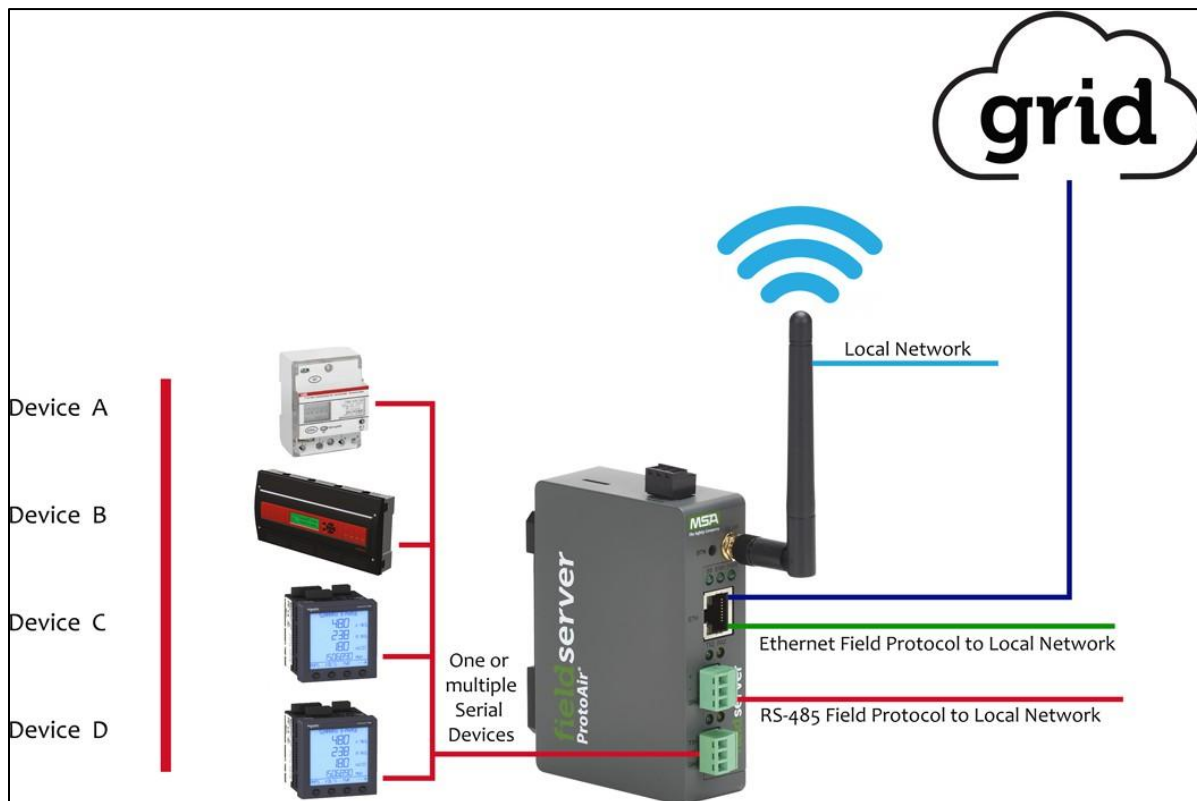

Figure 1-1: FPA-W44 Connectivity Diagram

1.2. Methods of Configuration

The ProtoAir offers two methods of configuration:

- **Auto-Discovery** (Section 6.2.1): Supported RS-485 devices can be automatically detected and identified for addition to the ProtoAir’s configuration via the ProtoAir’s Web Configurator.
- **Web Configurator** (Section 6.2.2): Devices that cannot be identified by Auto-Discovery must be configured to the gateway by selecting profiles on the ProtoAir’s Web Configurator. The Web Configurator shows all the stored profiles/devices on the ProtoAir. It will also show all the devices that were previously discovered or selected. To configure, select a device and enter the Modbus Node-ID. Once all required device profiles are saved, the ProtoAir automatically builds and downloads the configuration for the desired protocol.

Devices	Communication	Configuration Type
Mngr (AM units only)	Modbus RTU	Auto-Discovery
Dep (AM units only)	Modbus RTU	Auto-Discovery
C-More (select for Edge[i] and Edge[ii])	Modbus RTU	Auto-Discovery
Modulex	Modbus RTU	Auto-Discovery
ECS (select for SmartPlate except EV)	Modbus RTU	Auto-Discovery
BMS (select for BMSII and ACS)	Modbus RTU	Auto-Discovery
LMV3 (for MFC3000-6000 units)	Modbus RTU	Web-Configurator
LMV5 (for MFC8000 and 10000 units)	Modbus RTU	Web-Configurator
RWF55 (for MFC3000-6000 units)	Modbus RTU	Web-Configurator
Smartplate_EV	Modbus RTU	Auto-Discovery

2. SETUP FOR PROTOAIR

2.1. Record Identification Data

Each ProtoAir has a unique part number located on the side or the back of the unit. This number should be recorded, as it may be required for technical support. The numbers are:

AERCO ProtoAir	
Model	AERCO Part Number
ProtoAir	64213

- ProtoAir units have the following 3 ports: RS-485, Ethernet, RS-485

2.2. Point Count Capacity and Registers per Device

The total number of registers presented the device(s) attached to the ProtoAir cannot exceed:

Devices	Point Count Per Device
Mngr (AM units only)	95
Dep (AM units only)	95
C-More (select for Edge[i] and Edge[ii])	12
Modulex	10
ECS (select for SmartPlate except EV)	8
BMS (select for BMSII and ACS)	51
LMV3 (for MFC3000-6000 units)	56
LMV5 (for MFC8000 and 10000 units)	141
RWF55 (for MFC3000-6000 units)	73
Smartplate_EV	15

Part number	Total Registers
FPA-W44-2189	1,500

2.3. Configuring Device Communications

2.3.1. Confirm the Device and ProtoAir COM Settings Match

Any connected serial devices MUST have the same baud rate, data bits, stop bits, and parity settings as the ProtoAir. The table below specifies the serial port settings to communicate with the ProtoAir:

AERCO Device Serial Port Setting	Device
Protocol	Modbus RTU or Modbus RS-232
Baud Rate	9600
Parity	None
Data Bits	8
Stop Bits	1

2.3.2. Set Node-ID for Any Device Attached to the ProtoAir

- Set unique Node-ID (1-255) for any device attached to ProtoAir.
- Document the Node-ID that is assigned. The Node-ID assigned is used for deriving the Device Instance for BACnet IP and BACnet MS/TP (see Section 6).

NOTE: The Metasys N2 and Modbus TCP/IP field protocol Node-ID is automatically the same value as the Node-ID of the device.

2.4. Attaching the Wi-Fi Antenna

Screw on the Wi-Fi antenna to the front of the unit as shown in Section 10.5.

2.5. WATTS Device Connections to ProtoAir Device Port R1

The ProtoAir has a green 3-pin Phoenix connector for RS-485 or RS232 devices on the R1 port.

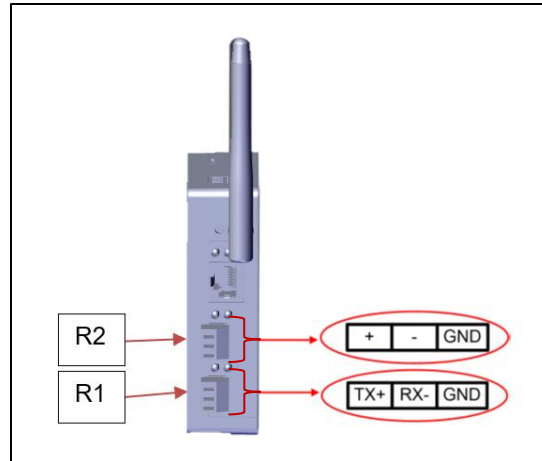

Figure 2-1: Connect R1 port to Watts / AERCO / PVI Equipment.

For the R1 Port only: Switch between RS-485 and RS-232 by moving the number 4 DIP Switch to OFF for RS-485 and ON for RS-232.

Connect to the 3-pin R1 connector as shown below.

The following baud rates are supported on the R1 Port: 9600, 19200, 38400, 57600, 76800, 115000

NOTE: Not all baud rates listed are supported by all protocols. Check the specific protocol driver manual for a list of the supported baud rates.

RS-485		RS-232	
AERCO Device RS-485 Wiring	ProtoAir Pin Assignment	AERCO Device RS-232 Wiring	ProtoAir Pin Assignment
RS-485 +	TX +	RS-232 TX	TX +
RS-485 -	RX -	RS-232 RX	RX -
GND	GND	RS-232 GND	GND

NOTE: The RS-485/RS-232 is part of the RS-485/RS-232 interface and must be connected to the corresponding terminal on the AERCO/WATTS Device. If the cable is shielded, the shield must connect only at one end.

⚠ WARNING!

Power Port uses the same identical connector as RS-485 communication ports (R1, R2). **DO NOT CONNECT THE POWER CONNECTOR TO A COMMUNICATION PORT. THIS WILL DAMAGE THE COMMUNICATION PORT.**

2.6. Wiring Field Port R2 to BAS RS-485 Serial Network

- Connect the RS-485 network wires to the green 3-pin RS-485 connector on the R2 port.
- The following baud rates are supported on the R2 Port: 9600, 19200, 38400, 57600, 76800, 115000.
 - RS-485 is part of the RS-485 interface and must be connected to the corresponding terminal on the BAS. If the cable is shielded, the shield must be connected only at one end.
 - See Section 4.1 for information on connecting to an Ethernet network.

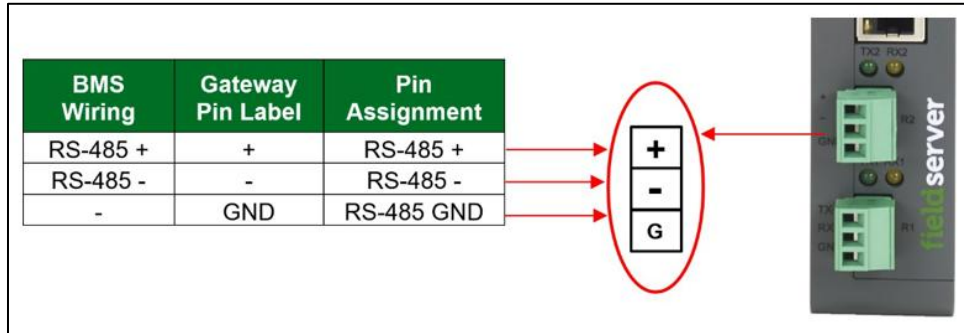

Figure 2-2: Connect R2 port to Building Automation System (BAS)

⚠ WARNING!

Power Port uses the same identical connector as RS-485 communication ports (R1, R2). DO NOT CONNECT THE POWER CONNECTOR TO A COMMUNICATION PORT. THIS WILL DAMAGE THE COMMUNICATION PORT.

2.7. Bias Resistors

To enable Bias Resistors, move both the BIAS- and BIAS+ DIP switches to ON (the right in the orientation shown below).

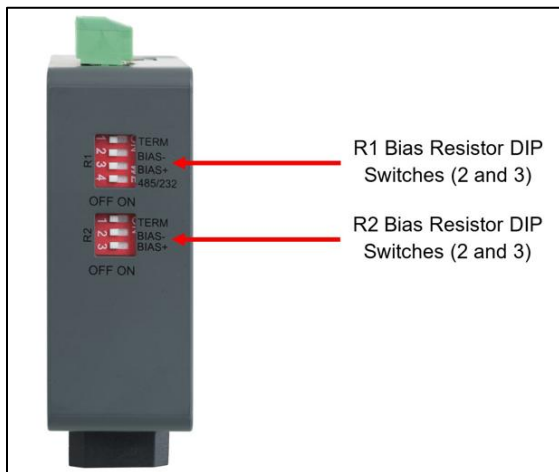

The bias resistors are used to keep the RS-485 bus to a known state, when there is no transmission on the line (bus is idling), to help prevent false bits of data from being detected. The bias switches pull one line high and the other low.

The bias resistor is 510 ohms which is in line with the BACnet spec. It should only be enabled at one point on the bus (for example, on the field port where there are very weak bias resistors of 100k). Since there are no jumpers, many ProtoAirs can be put on the network without running into the bias resistor limit which is < 500 ohms.

NOTE: The R1 and R2 DIP Switches apply settings to the respective serial port.

2.8. Termination Resistor

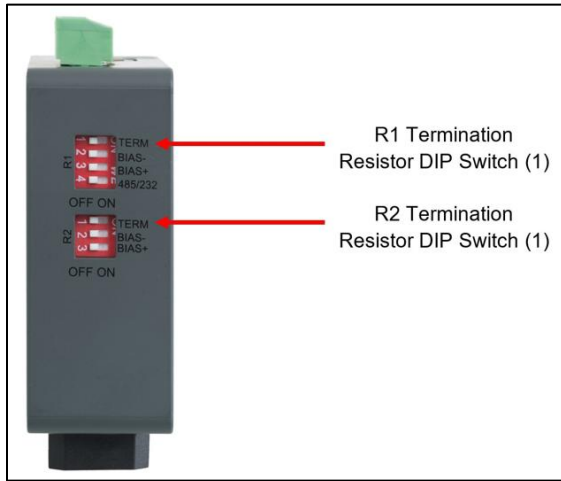

If the gateway is the first or last device on the serial trunk, then the End-Of-Line Termination Switch needs to be enabled. **To enable the termination resistor, move the TERM dip switch to ON (the right in the orientation shown above).**

The termination resistor is also used to reduce noise. It pulls the two lines of an idle bus together. However, the resistor would override the effect of any bias resistors if connected. The R1 termination resistor is 120 Ohms.



NOTE: The R1 and R2 DIP Switches apply settings to the respective serial port.

3. BACNET IP or MODBUS TCP/IP: Change The ProtoAir IP Address

3.1. Connect the PC to ProtoAir via the Ethernet Port

- Connect a CAT5 Ethernet cable (Straight through or Cross-Over) between the PC and ProtoAir.
- The Default IP Address of ProtoAir is **192.168.1.24**, Subnet Mask is **255.255.255.0**. If the PC and ProtoAir are on different IP Networks, assign a static IP Address to the PC on the 192.168.1.xxx network.

- **For Windows XP:**

1. Click  , choose **Control Panel**, and then choose **NetworkConnections**.
2. Right-click on **Local Area Connection** and choose **Properties**.
3. Highlight  Internet Protocol (TCP/IP) > 

- **For Windows 7:**

1. Click  and choose **Control Panel**.
2. If the Control Panel is displayed by category, click **Network and Internet** and then choose **Network and Sharing Center**.
If the Control Panel is displayed by icon, choose **Network and Sharing Center**.
3. Choose **Change adapter settings** in the left pane.
4. Right-click on **Local Area Connection** and choose **Properties**.
5. Highlight **Internet Protocol Version 4 (TCP/IPv4)** and click **Properties**.

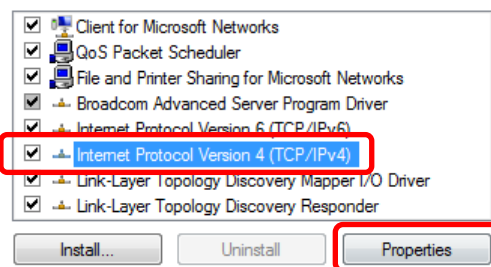

- Click on the **Use the following IP address** radio button and type in the IP Address.

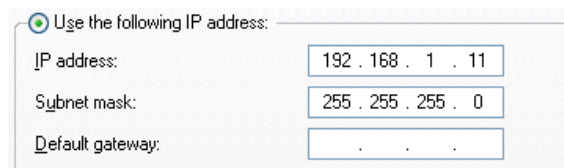

Use the following IP address:

IP address:

Subnet mask:

Default gateway:

- Click the **OK** button twice to complete the process.

3.2. BACnet IP and Modbus TCP/IP: Setting IP Address for Field Network

- After setting your PC to be on the same subnet as the ProtoAir (Section 3), open a web browser on your PC and enter the IP Address of the ProtoAir; the default address is **192.168.1.24**.
- The Web Configurator will be displayed as your landing page (see Figure 4-1).
- Below the Active Profiles heading you should see profiles listed for connected devices. If no profiles are present, then the wiring, baud rate, and DIP switch settings must be checked, because there is a problem with device communications. All the active profiles must show the correct Node-ID's before proceeding.
- To access the Web GUI, click on the **Diagnostics & Debugging** button in the lower-right side of the page.

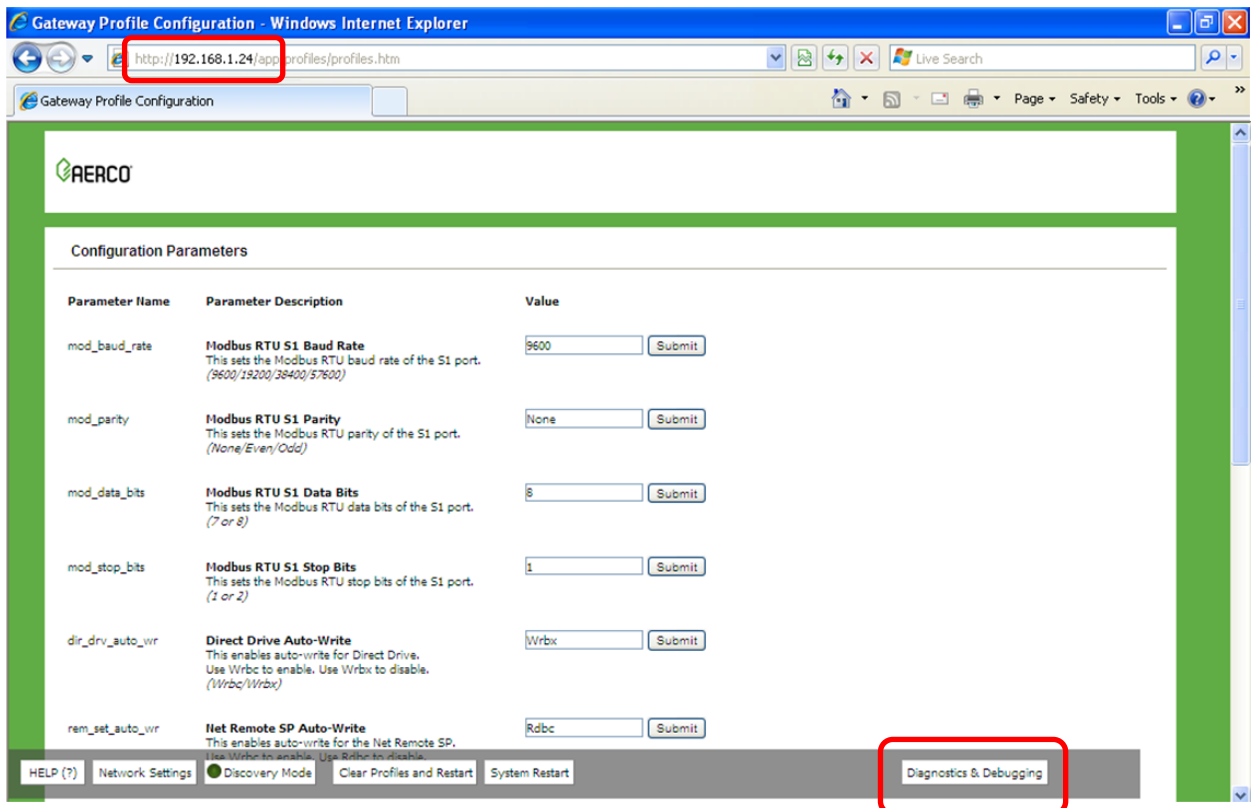

Figure 3-1: Web Configurator Screen with Active Profiles

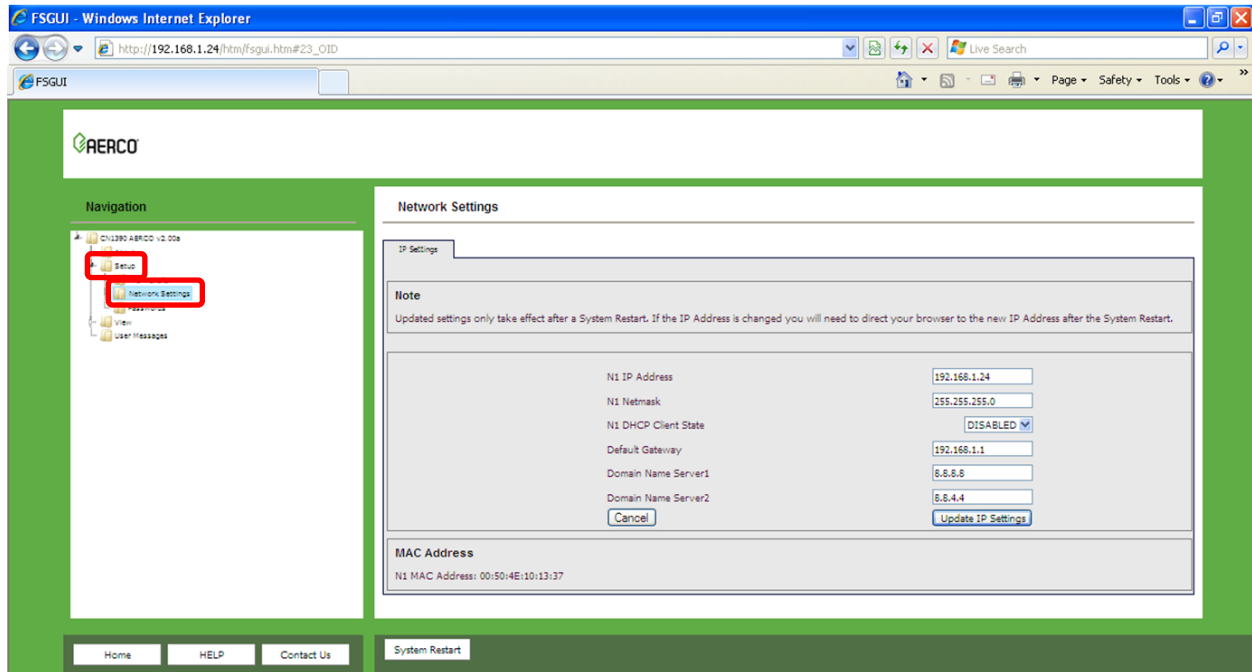

Figure 3-2: Changing IP Address via Web GUI

- From the Web GUI's landing page, click on **Setup** to expand the navigation tree and then select **Network Settings** to access the IP Settings menu (Figure 4-2).
- Modify the IP Address (N1 IP Address field) of the ProtoAir Ethernet port.
- If necessary, change the Netmask (N1 Netmask field).
- Type in a new Subnet Mask
- If necessary, change the IP Gateway (Default Gateway field)
- Type in a new IP Gateway

NOTE: If the ProtoAir is connected to a router, the IP Gateway of the ProtoAir should be set to the IP Address of the router that it is connected to.

- Reset ProtoAir
- Unplug Ethernet cable from PC and connect it to the network hub or router
- **Record the IP Address assigned to the ProtoAir for future reference.**

4. POWER UP THE GATEWAY

Check power requirements in the table below:

Power Requirement for ProtoAir External Gateway		
	Current Draw Type	
ProtoAir Family	12VDC	24VDC/AC
FPA –W44 (Typical)	250mA	125mA

NOTE: These values are 'nominal' and a safety margin should be added to the power supply of the host system. A safety margin of 25% is recommended.

Apply power to the ProtoAir as shown below. Ensure that the power supply used complies with the specifications provided in Section 11 Specifications.

- The gateway accepts 12-24VDC or 24VAC on pins L+ and N-.
- Frame GND should be connected to ensure personnel safety and to limit material damages due to electrical faults. Ground planes are susceptible to transient events that cause sudden surges in current. The frame ground connection provides a safe and effective path to divert the excess current from the equipment to earth ground.

NOTE: Floating AC Power Supplies are supported.

Power to ProtoAir	ProtoAir Pin Label	Pin Assignment
Power In (+)	L +	V +
Power In (-)	N -	V -
Frame Ground	FG	FRAME GND

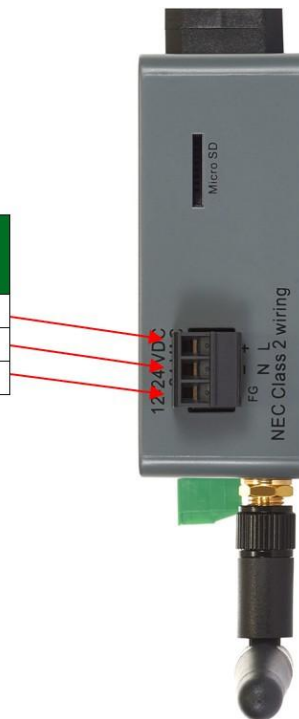

⚠ WARNING!

Power Port uses the same identical connector as RS-485 communication ports (R1, R2). DO NOT CONNECT THE POWER CONNECTOR TO A COMMUNICATION PORT. THIS WILL DAMAGE THE COMMUNICATION PORT.

5. CONNECT THE PC TO THE GATEWAY

There are two ways to connect the PC to the ProtoAir, either by Ethernet cable (Section 4.1) or Wi-Fi Access Point via Laptop or Cell Phone (Section 4.2).

5.1. Connecting to the Gateway via Ethernet

Connect a Cat-5 Ethernet cable (straight through or cross-over) between the local PC and ProtoAir.

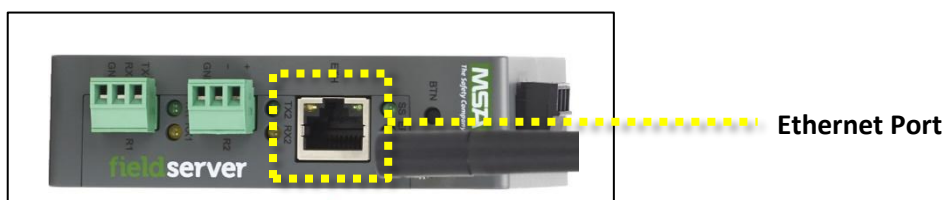

5.1.1. Changing the Subnet of the Connected PC

The default ProtoAir IP Address is **192.168.1.24**, Subnet Mask is **255.255.255.0**. If the PC and ProtoAir are on different IP networks, assign a static IP Address to the PC on the 192.168.1.xxx network.

For Windows 10:

- Use the search field in the PC’s taskbar to the right of the windows icon and type “Control Panel”.
- Click “Control Panel”, click “Network and Internet” and then click “Network and Sharing Center”.
- Click “Change adapter settings” on the left side of the window.
- Right-click on “Local Area Connection” and select “Properties” from the dropdown menu.
- Highlight [Internet Protocol Version 4 \(TCP/IPv4\)](#) and then click the Properties button.
- Select and enter a static IP Address on the same subnet. For example:

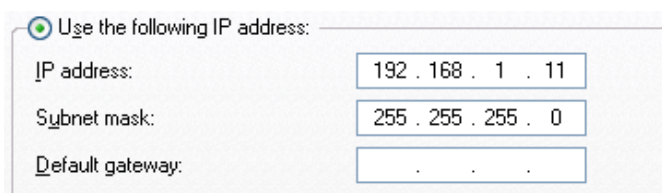

- Click Okay to close the Protocol window and click Close to exit the Ethernet Properties window.

5.2. Connecting to the Gateway over Wi-Fi Access Point

When the ProtoAir is first powered up, the Wi-Fi Access Point will be enabled allowing direct connection to the gateway with Wi-Fi.

To connect to the ProtoAir Wi-Fi Access Point:

- Click the network icon (found in the bottom-right corner of the computer screen) to open the available Wireless Network Connections, or on your cell Phone go to Settings → Connections → WiFi. Look for the “ProtoAir-60FA92” or similar network connection.

- Select the desired gateway and click Connect.



- Enter the Security key. The default is “12345678”.



- The available Wireless Network Connection menu should now show that the computer is connected to the ProtoAir.

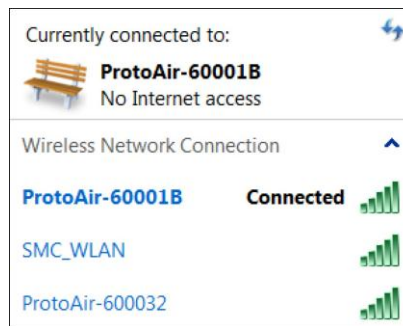

5.3. Navigate to the Login Page

Open a web browser and connect to the FieldServer’s default IP Address. The default IP Address of the ProtoAir via WiFi is 192.168.50.1.

NOTE: If the IP Address of the ProtoAir has been changed, the IP Address can be discovered using the FS Toolbox utility. See Section 8.1.

6. SETUP WEB SERVER SECURITY

6.1. Login to the FieldServer

The first time the FieldServer GUI is opened in a browser, the IP Address for the gateway will appear as untrusted. This will cause the following pop-up windows to appear.

- When the Web Server Security Unconfigured window appears, read the text and choose whether to move forward with HTTPS or HTTP.



- When the warning that "Your connection is not private" appears, click the advanced button on the bottom left corner of the screen.

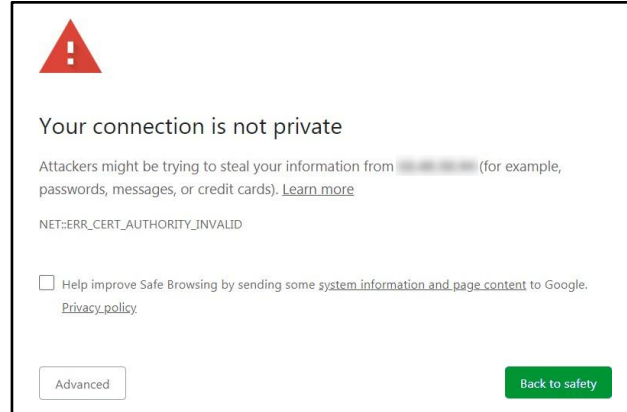

- Additional text will expand below the warning, click the underlined text to go to the IP Address. In the example below this text is "Proceed to <FieldServer IP> (unsafe)".

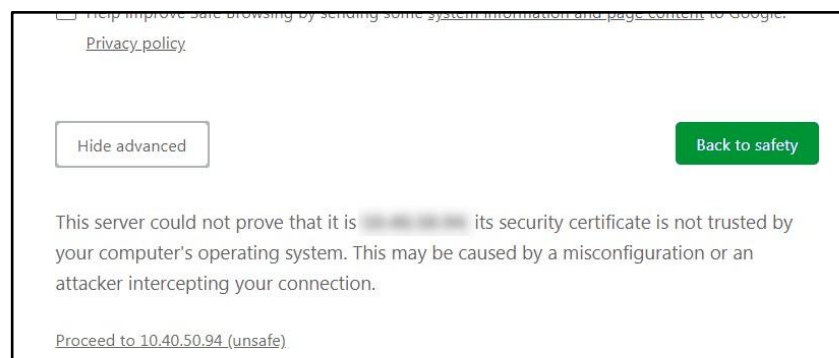

- When the login screen appears, put in the Username (default is “admin”) and the Password (found on the label of the FieldServer).

NOTE: There is also a QR code in the top right corner of the FieldServer label that shows the default unique password when scanned.

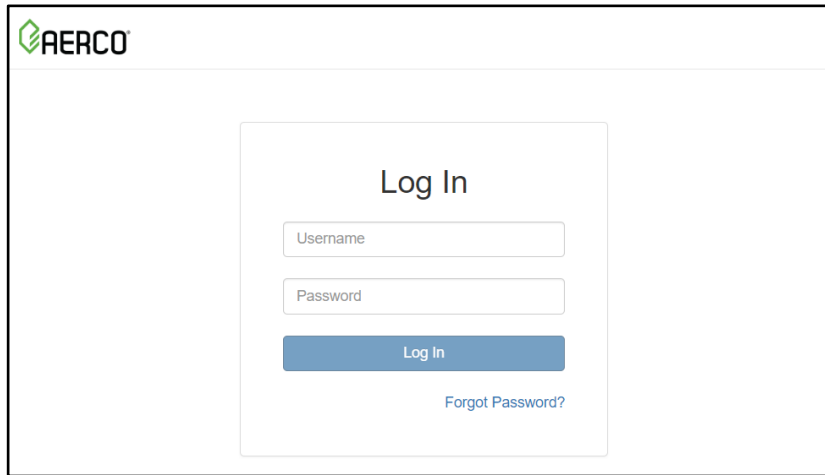

NOTE: A user has 5 attempts to login then there will be a 10-minute lockout. There is no timeout on the FieldServer to enter a password.

NOTE: To create individual user logins, go to Section 9.7.

6.2. Select the Security Mode

On the first login to the FieldServer, the following screen will appear that allows the user to select which mode the FieldServer should use.

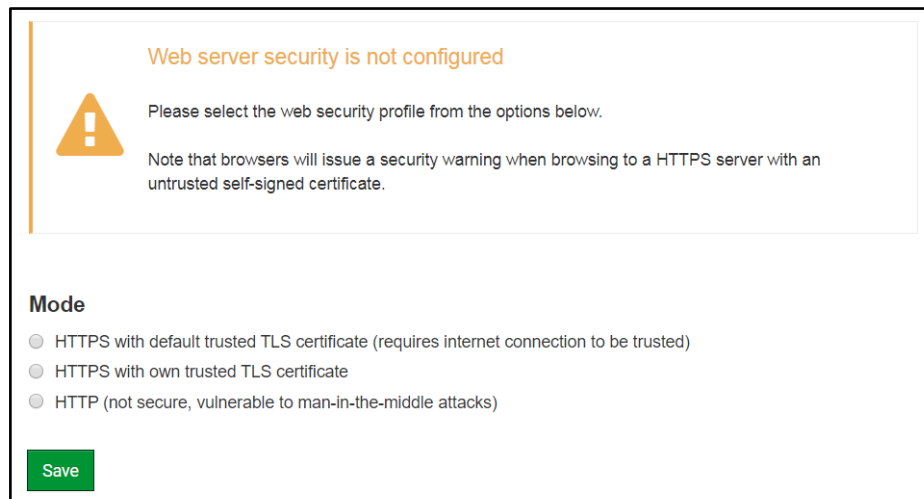

NOTE: Cookies are used for authentication.
NOTE: To change the web server security mode after initial setup, go to Section 9.6 Change Web Server Security Settings After Initial Setup.

The sections that follow include instructions for assigning the different security modes.

6.2.1. HTTPS with Own Trusted TLS Certificate

This is the recommended selection and the most secure. **Please contact your IT department to find out if you can obtain a TLS certificate from your company before proceeding with the Own Trusted TLS Certificate option.**

- Once this option is selected, the Certificate, Private Key and Private Key Passphrase fields will appear under the mode selection.

Certificate

```
XzyMbQZFiRuwJZJPe7CTHLcHOrHLowoUFoVtaBMYd4d6VGdNklKazByWKcNOL7mrX
A4lBAQBfM+IPvOx3T/47VEmaiXqE3bx3zEuBFJ6pWPlw7LHf2r2ZoHw+9xb+aNMU
dVvAelhBMTMsnI2ERvQVp0xi3psSv2EJyKXS1bOYNRLsq7UzpwuAdT/Wy3o6vUM5
K+Cwf9qEoQ0LuxDZTIECt67MkcHMiuFi5pk7TRicHnQF/sfOAYOulduHOy9exlk9
FmHFVDIz/cJUaF+e74EuSph+gEr0lQo2wymhyc7L22UXse1NoOfU2Zq0Eu1VVtu
JRyvaMwIRFEWuuzMGZIKFEWVC+8q2JQsVcgrWm7naoblLEhOCMH+sKHJMCxDoXGt
vtZjpZu0AL51YXxWSVcyZdGIAP5e
-----END CERTIFICATE-----
```

Private Key

```
sHB0zZoHr4YQSDk2BbYVzzbl0LDuKtC8+JiO3ooGjoTuHnqkeAj/fKfbTAsKeAzW
gkQe+H5UQNK0bdvZfOJrm6daDK2vVDmR5k+JUUhEj5N49uplroB97MQqYotzqfT+
THlbpq5t1SIK617k04ObKmHF5l8fck+ru545sVmpeeZh0m5j5SURYAZMvbg5daCu
J4l5NlihbEvxRF4UK41ZDMCvujioPcBKUWrb1a/3XXnDnM2K9xyz2wze998D6Wk46
+7aQFY9F+7j5lJmkoS3GYtwCyH5jP+mPP1K6RnuIDQ19wwwGPb4dtN/RTnfdQeF
GYeVSkI9fxxkxDOFtdWRZbM/rPjn4tm01Xf8HqONVN1x/jaMynOXG4cukoi4+VO
u0rZaUJEsllzNkfm7fAA5m5NBWg202Cy9IAYnuujs3aAlI5uGBeekA62oTMxlzx
-----END RSA PRIVATE KEY-----
```

Private Key Passphrase

Specify if encrypted

Save

- Copy and paste the Certificate and Private Key text into their respective fields. If the Private Key is encrypted type in the associated Passphrase.
- Click Save.
- A “Redirecting” message will appear. After a short time, the FieldServer GUI will open.

6.2.2. HTTPS w/ Default Untrusted Self-Signed TLS Certificate or Built-in Payload Encryption

- Select one of these options and click the Save button.
- A “Redirecting” message will appear. After a short time, the FieldServer GUI will open.

7. CONFIGURE THE PROTOAIR

7.1. Select Field Protocol and Set Configuration Parameters

- On the Web Configurator page, the first configuration parameter is the Protocol Selector.

Parameter Name	Parameter Description	Value
protocol_select	Protocol Selector Set to 1 for BACnet IP Set to 2 for BACnet MSTP Set to 3 for Metasys N2 Set to 4 for Modbus TCP Set to 5 for BST TCP db up to 16 WHM Units Set to 6 for BST BAC db up to 16 WHM Units Set to 7 for BST N2 db up to 16 WHM Units Set to 8 for BACnet MSTP/BACnet IP (single node)	1 <input type="button" value="Submit"/>
mod_baud_rate	Modbus RTU R1 Baud Rate This sets the Modbus RTU baud rate of the R1 port. (9600/19200/38400/57600)	9600 <input type="button" value="Submit"/>
mod_parity	Modbus RTU R1 Parity This sets the Modbus RTU parity of the R1 port.	None <input type="button" value="Submit"/>

HELP (?) Discovery Mode Clear Profiles and Restart System Restart Diagnostics & Debugging fieldserver

- Select the field protocol by entering the appropriate number into the Protocol Selector Value. Click the Submit button. Click the System Restart button to save the updated configuration.

NOTE: Protocol specific parameters are only visible when the associated protocol is selected.

NOTE: If Modbus TCP/IP was selected and is used for the field protocol, skip Section 6.2. Device profiles are NOT used for Modbus TCP/IP. Ensure all parameters are entered for successful operation of the gateway. Find the legal value options for each parameter under the Parameter Description in parentheses.

NOTE: If multiple devices are connected to the ProtoAir, set the BACnet Virtual Server Nodes field to “Yes”; otherwise leave the field on the default “No” setting.

Protocol Selector:

- Set to 1 for BACnet IP
- Set to 2 for BACnet MSTP
- Set to 3 for Metasys N2
- Set to 4 for Modbus TCP or Modbus RTU
- Set to 5 for Modbus TCP or Modbus RTU up to 16 BST or WHM Units
- Set to 6 for BACnet IP or BACnet MSTP up to 16 BST or WHM Units
- Set to 7 for Metasys N2 up to 16 BST or WHM Units
- Set to 8 for Single Node Option for BACnet MSTP or BACnet IP

NOTE: Use Single Node Option (8) if your BAS cannot work with Virtual Server Nodes under the same MAC Address. In this case the units will show as 1 node with unit address 1 data starting at address 1001, unit address 2 data starting at 2001, unit address 3 data starting at 3001, etc.

NOTE: Be sure to select the appropriate “BACnet Protocol Option” – MSTP or IP.

7.2. Configure Devices Connected to the Gateway

7.2.1. Use Discovery Mode

This configuration method works only with devices set as Auto-Discovery in Section 1.2.

- Click the Discovery Mode button at the bottom of the screen.

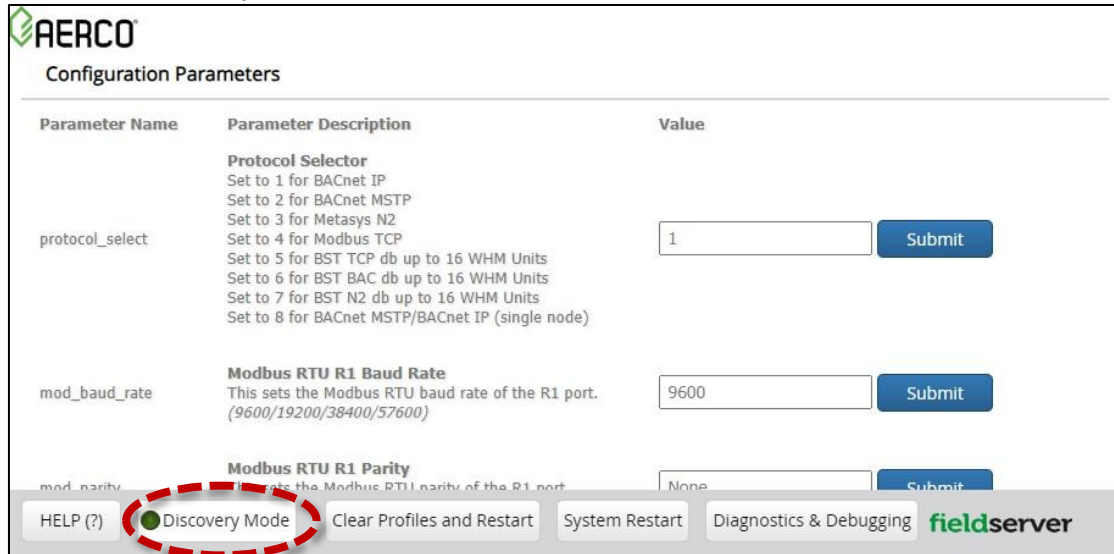

- Click the OK button in the window that appears to discover devices and restart the device.
- Wait for the ProtoAir to restart and the Discovery in Progress window to disappear.

NOTE: It may take up to 10 minutes for all the devices to be discovered and the configuration file to be built.

- If the discovery is successful, the desired device profile should appear under the Active profiles title near the bottom of the screen.



NOTE: Scroll down the page if the Active profiles header is not visible.

7.2.2. Setting Active Profiles

This section applies to Web Configurator devices referenced in Section 1.2.

- In the Web Configurator, Active Profiles are shown below the configuration parameters. This list is empty for new installations, or after clearing all configurations.

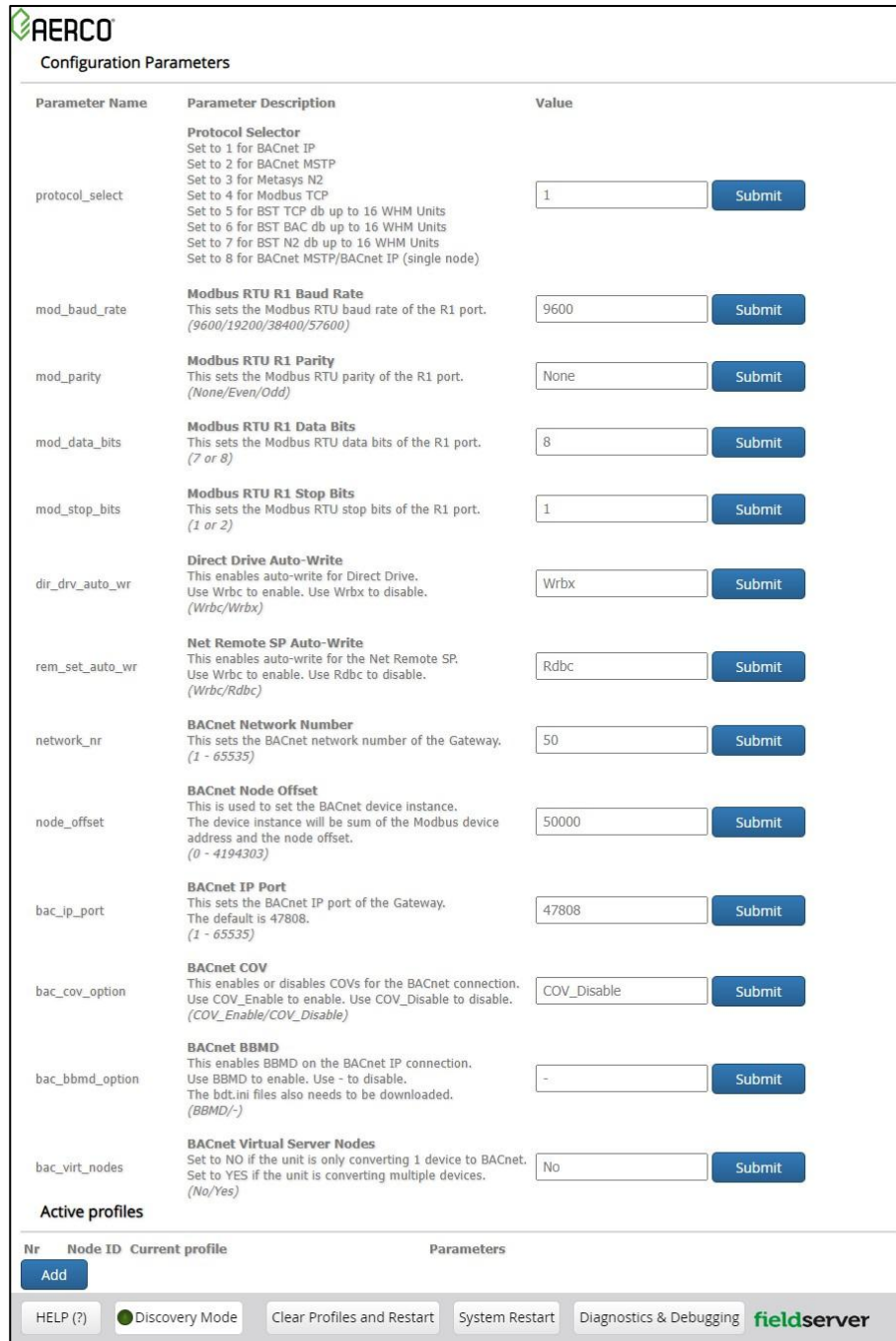

Parameter Name	Parameter Description	Value
protocol_select	Protocol Selector Set to 1 for BACnet IP Set to 2 for BACnet MSTP Set to 3 for Metasys N2 Set to 4 for Modbus TCP Set to 5 for BST TCP db up to 16 WHM Units Set to 6 for BST BAC db up to 16 WHM Units Set to 7 for BST N2 db up to 16 WHM Units Set to 8 for BACnet MSTP/BACnet IP (single node)	1 <input type="button" value="Submit"/>
mod_baud_rate	Modbus RTU R1 Baud Rate This sets the Modbus RTU baud rate of the R1 port. (9600/19200/38400/57600)	9600 <input type="button" value="Submit"/>
mod_parity	Modbus RTU R1 Parity This sets the Modbus RTU parity of the R1 port. (None/Even/Odd)	None <input type="button" value="Submit"/>
mod_data_bits	Modbus RTU R1 Data Bits This sets the Modbus RTU data bits of the R1 port. (7 or 8)	8 <input type="button" value="Submit"/>
mod_stop_bits	Modbus RTU R1 Stop Bits This sets the Modbus RTU stop bits of the R1 port. (1 or 2)	1 <input type="button" value="Submit"/>
dir_drv_auto_wr	Direct Drive Auto-Write This enables auto-write for Direct Drive. Use Wrbc to enable. Use Wrbx to disable. (Wrbc/Wrbx)	Wrbx <input type="button" value="Submit"/>
rem_set_auto_wr	Net Remote SP Auto-Write This enables auto-write for the Net Remote SP. Use Wrbc to enable. Use Rdbc to disable. (Wrbc/Rdbc)	Rdbc <input type="button" value="Submit"/>
network_nr	BACnet Network Number This sets the BACnet network number of the Gateway. (1 - 65535)	50 <input type="button" value="Submit"/>
node_offset	BACnet Node Offset This is used to set the BACnet device instance. The device instance will be sum of the Modbus device address and the node offset. (0 - 4194303)	50000 <input type="button" value="Submit"/>
bac_ip_port	BACnet IP Port This sets the BACnet IP port of the Gateway. The default is 47808. (1 - 65535)	47808 <input type="button" value="Submit"/>
bac_cov_option	BACnet COV This enables or disables COVs for the BACnet connection. Use COV_Enable to enable. Use COV_Disable to disable. (COV_Enable/COV_Disable)	COV_Disable <input type="button" value="Submit"/>
bac_bbmd_option	BACnet BBMD This enables BBMD on the BACnet IP connection. Use BBMD to enable. Use - to disable. The bdt.ini files also needs to be downloaded. (BBMD/-)	- <input type="button" value="Submit"/>
bac_virt_nodes	BACnet Virtual Server Nodes Set to NO if the unit is only converting 1 device to BACnet. Set to YES if the unit is converting multiple devices. (No/Yes)	No <input type="button" value="Submit"/>

Active profiles

Nr	Node ID	Current profile	Parameters
<input type="button" value="Add"/>			

HELP (?) Discovery Mode fieldserver

- To add an active profile to support a device, click the Add button under the Active Profiles heading. This will present a drop-down menu underneath the Current profile column.
- Once the Profile for the device has been selected from the drop-down list, enter the value of the device’s Node-ID which was assigned in Section 2.3.2 Set Node-ID for Any Device Attached to the ProtoAir.

- Then press the “Submit” button to add the Profile to the list of devices to be configured.
- Repeat this process until all the devices have been added.
- Completed additions are listed under “Active profiles” as shown below

Active profiles

Nr	Node ID	Current profile	Parameters
1	1	BAC_IP_LMV3	Remove
2	22	BAC_IP_LMV5	Remove
3	33	BAC_IP_RWF55	Remove

Add

HELP (?) Discovery Mode Clear Profiles and Restart System Restart Diagnostics & Debugging **fieldserver**

7.3. Verify Device Communications

- If using a serial connection, check that TX and RX LEDs are rapidly flashing (Section 8.4).
- Confirm the software shows good communications without errors (Section 8.2).

7.4. BACnet: Setting Node_Offset to Assign Specific Device Instances

- Follow the steps outlined in Section 5 to access the ProtoAir Web Configurator.
- The BACnet Node Offset field shows the current value (default = 50,000).
 - The values allowed for a BACnet Device Instance can range from 1 to 4,194,303
- To assign a specific Device Instance (or range); change the BACnet Node Offset value as needed using the calculation below:

$$\text{Device Instance (desired)} = \text{BACnet Node Offset} + \text{Node_ID}$$

For example, if the desired Device Instance for the device 1 is 50,001 and the following is true:

- Device 1 has a Node-ID of 1
- Device 2 has a Node-ID of 22
- Device 3 has a Node-ID of 33

Then plug the device 1’s information into the formula to find the desired Node Offset:

$$50,001 = \text{BACnet Node Offset} + 1$$

$$\mathbf{50,000 = \text{BACnet Node Offset}}$$

Once the BACnet Node Offset value is input, it will be applied as shown below:

- Device 1 Instance = 50,000 + Node_ID = 50,000 + 1 = 50,001
- Device 2 Instance = 50,000 + Node_ID = 50,000 + 22 = 50,022
- Device 3 Instance = 50,000 + Node_ID = 50,000 + 33 = 50,033

Click “Submit” once the desired value is entered.

BACnet Node Offset
 This is used to set the BACnet device instance.
 The device instance will be sum of the Modbus device address and the node offset.
 (0 - 4194303)

node_offset Submit

Active profiles

Nr	Node ID	Current profile	Parameters
1	1	BAC_IP_LMV3	
2	22	BAC_IP_LMV5	
3	33	BAC_IP_RWF55	

Remove
Remove
Remove

Add

HELP (?)
 Discovery Mode
 Clear Profiles and Restart
System Restart
Diagnostics & Debugging
fieldserver

NOTE: For Single Node Option (8) selection there is only one node and therefore one Device Instance and so you set the “BACnet Device Instance” directly in the Web Configurator page.

7.5. How to Start the Installation Over: Clearing Profiles

- Follow the steps outlined in Section 5 to access the ProtoAir Web Configurator.
- At the bottom-left of the page, click the “Clear Profiles and Restart” button.
- Once restart is complete, all past profiles discovered and/or added via Web Configurator are deleted. The unit can now be reinstalled.

8. SETUP NETWORK

8.1. Using FS-GUI to Input Network Settings

To navigate from the FS-GUI page to the Network Settings page follow the below instructions:

- From the Web Configurator page, click the Diagnostics & Debugging button on the bottom of the screen to open the FS-GUI page.
- Find the Navigation tree across the left side of the screen.
- Click the arrow next to the FieldServer title/CN number to expand the tree.

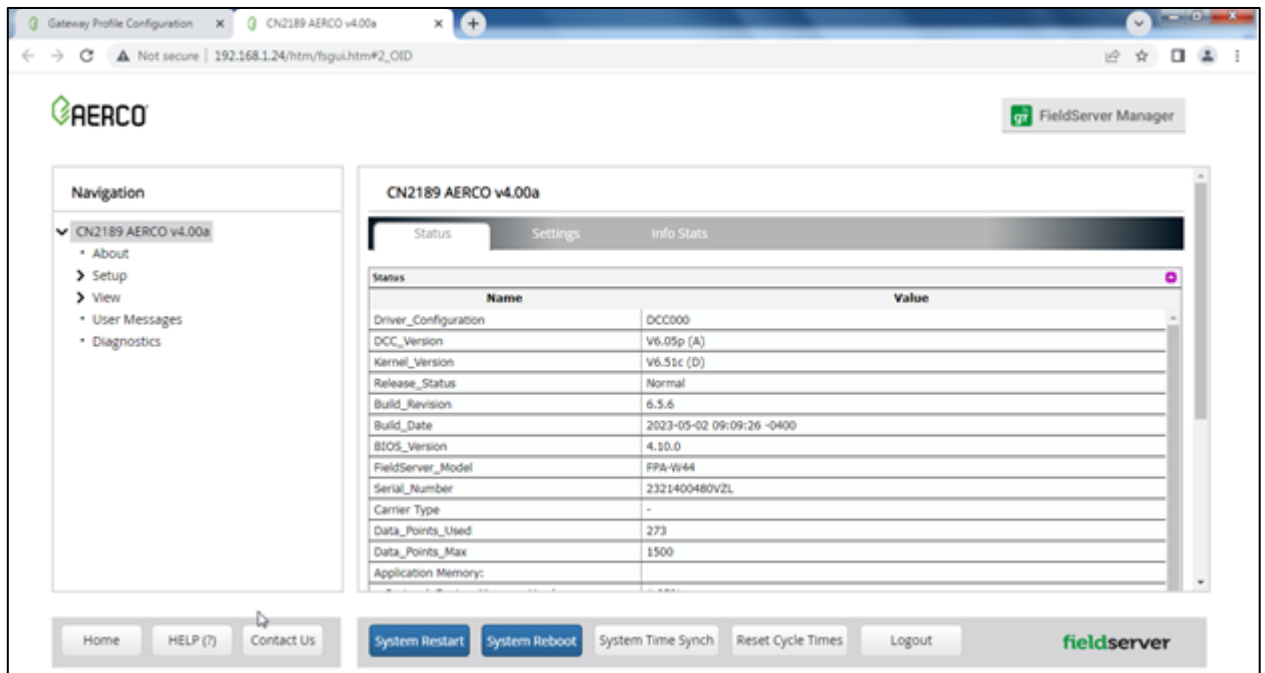

- Click on the arrow next to Setup to expand the tree.
- Click on Network Settings.

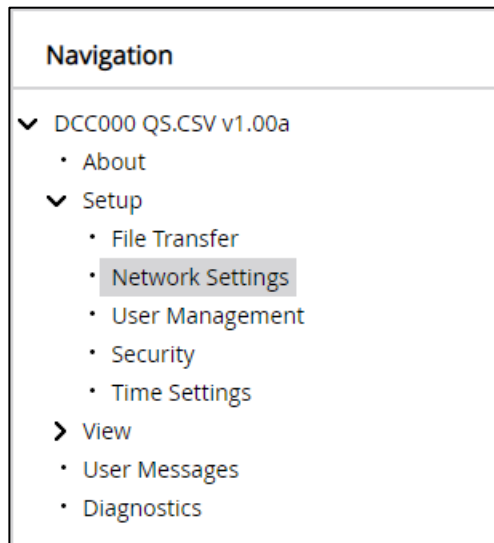

8.2. Change the ProtoAir IP Address

Configure the IP settings of the ProtoAir using the following sections of the Network page:

- If using the Ethernet port to connect to the local network, scroll to “ETH 1” (Section 7.2.2).
- If connecting to a local wireless network, scroll to “WiFi Client Settings” (Section 7.2.3).
- If updating Wi-Fi Access Point settings, scroll to “WiFi Access Point Settings” (Section 7.2.4).

8.2.1. Routing Settings

The Routing settings make it possible to set up the IP routing rules for the FieldServer’s internet and network connections.

- Click the Add Rule button to add a new row and set a new Destination Network, Netmask and Gateway IP Address as needed.
- Set the Priority for each connection (1-255 with 1 as the highest and 255 as the lowest).
- Click the Save button to activate the new settings.

NOTE: If using Wi-Fi Client and not Ethernet, make the top priority rule a Wi-Fi Client connection.

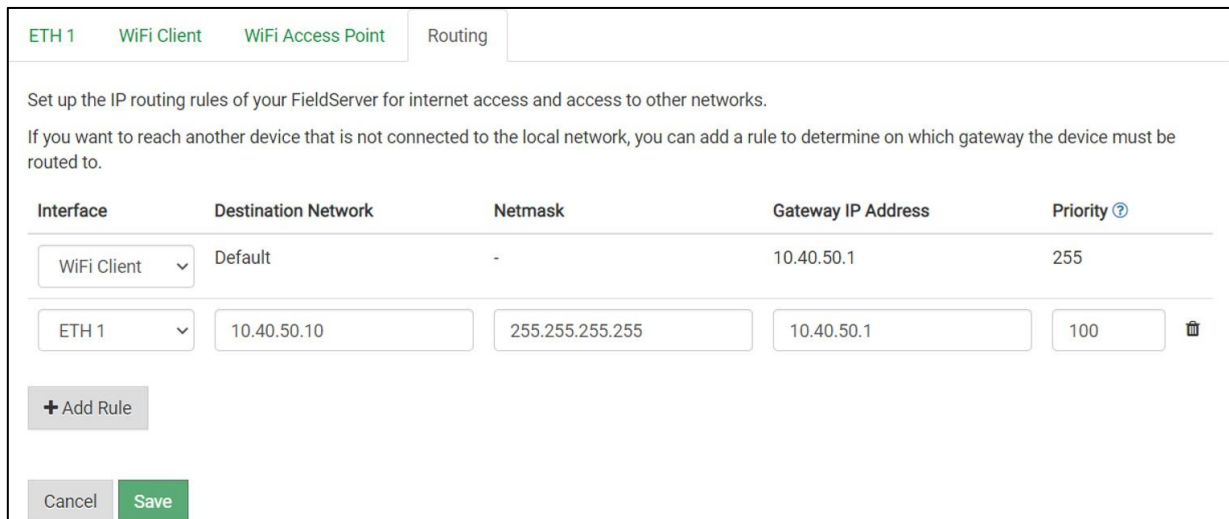

Interface	Destination Network	Netmask	Gateway IP Address	Priority ?
WiFi Client	Default	-	10.40.50.1	255
ETH 1	10.40.50.10	255.255.255.255	10.40.50.1	100

+ Add Rule

Cancel Save

8.2.2. Ethernet 1

The ETH 1 section contains the wired network settings. To change the FieldServer IP Settings, follow these instructions:

- Enable DHCP to automatically assign or modify IP Settings manually as needed, via these fields: **IP Address**, **Netmask**, **Default Gateway**, and **Domain Name Server1/2**.

NOTE: If the FieldServer is connected to a router, the IP Gateway of the FieldServer should be set to the same IP Address of the router.

- Click Save to record and activate the new IP Address.
- Connect the FieldServer to the local network or router.

NOTE: The browser must update to the new FieldServer IP Address before settings are accessible.

ETH 1
WiFi Client
WiFi Access Point
Routing

Enable DHCP

IP Address

Netmask

Gateway

Domain Name Server 1 (Optional)

Domain Name Server 2 (Optional)

Network Status

Connection Status	✔ Connected
MAC Address	00:50:4e:60:01:fd
Ethernet Tx Msgs	498,827
Ethernet Rx Msgs	1,384,116
Ethernet Tx Msgs Dropped	0
Ethernet Rx Msgs Dropped	0

8.2.3. Wi-Fi Client Settings

- Set Wi-Fi Status to ENABLED for the ProtoAir to communicate with other devices via Wi-Fi.
- Enter the Wi-Fi SSID and Wi-Fi Password for the local wireless access point.
- Enable DHCP to automatically assign all Wi-Fi Client Settings fields or modify the Settings manually, via the fields immediately below the note (IP Address, Network, etc.).

NOTE: If connected to a router, set the IP gateway to the same IP Address as the router.

- Click the Save button to activate the new settings.
- Go to Routing Settings (Section 7.2.1) to set the default connection to Wi-Fi Client.

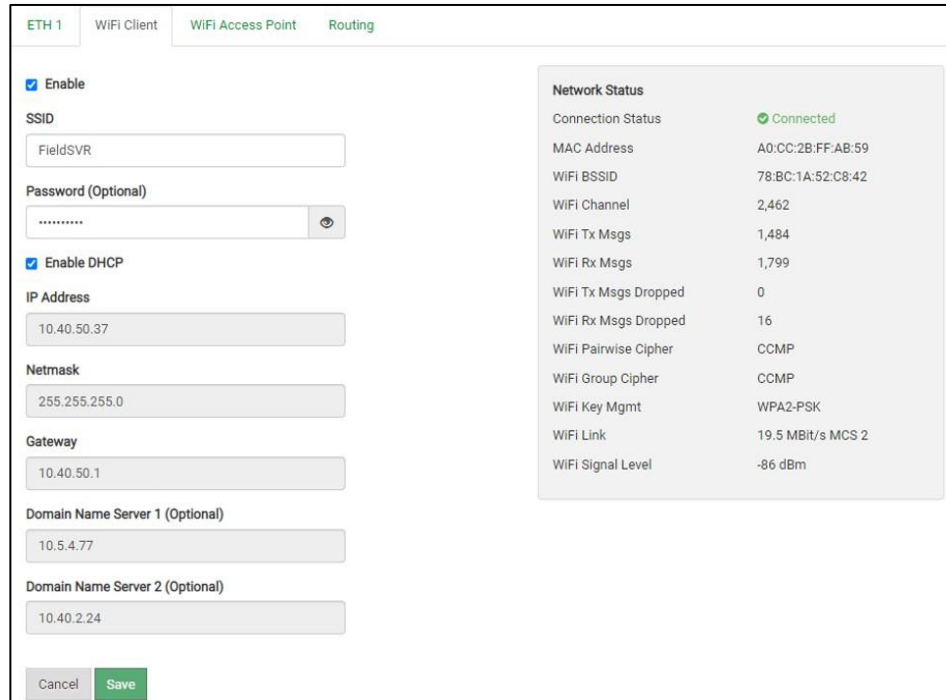

8.2.4. Wi-Fi Access Point Settings

- Check the Enable tick box to allow connecting to the ProtoAir via Wi-Fi Access Point.
- Modify the Settings manually as needed, via these fields: SSID, Password, Channel, IP Address, Netmask, IP Pool Address Start, and IP Pool Address End.

NOTE: The default channel is 11. The default IP Address is 192.168.50.1.

- Click the Save button to activate the new settings.

NOTE: If the webpage was open in a browser via Wi-Fi, the browser will need to be updated with the new Wi-Fi details before the webpage is accessible again.

ETH 1 WiFi Client WiFi Access Point **Routing**

Enable

SSID
ProtoAir-6001FD

Password (Optional)
.....

Channel
11

Allow others to find this network

Enable hotspot

IP Address
192.168.50.1

Netmask
255.255.255.0

IP Pool Address Start
192.168.50.120

IP Pool Address End
192.168.50.130

Cancel Save

Network Status

Connection Status	Disabled
Access Point MAC Address	a0:cc:2b:ff:ab:59
Access Point Tx Msgs	0
Access Point Rx Msgs	0
Access Point Tx Msgs Dropped	0
Access Point Rx Msgs Dropped	0

9. TROUBLESHOOTING

9.1. Lost or Incorrect IP Address

- Ensure that FieldServer Toolbox is loaded onto the local PC. Otherwise, download the FieldServer-Toolbox.zip via the MSA Safety website.
- Extract the executable file and complete the installation.
- Connect a standard Cat-5 Ethernet cable between the user's PC and ProtoAir.
- Double click on the FS Toolbox Utility and click Discover Now on the splash page.
- Check for the IP Address of the desired gateway.

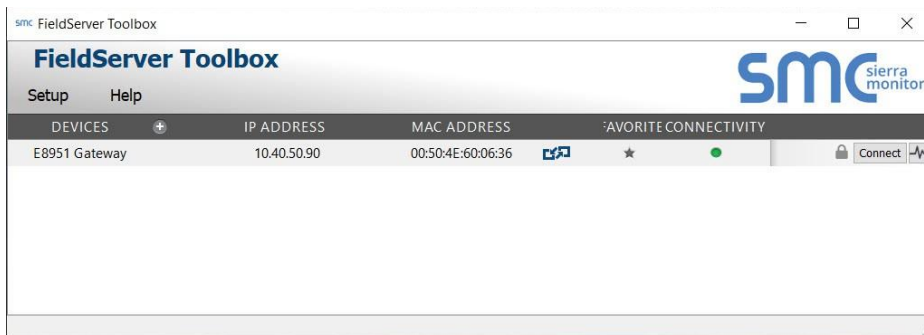

9.2. Viewing Diagnostic Information

- Type the IP Address of the FieldServer into the web browser or use the FieldServer Toolbox to connect to the FieldServer.
- Click on Diagnostics and Debugging Button, then click on view, and then on connections.
- If there are any errors showing on the Connection page, refer to Section 8.3 for the relevant wiring and settings.

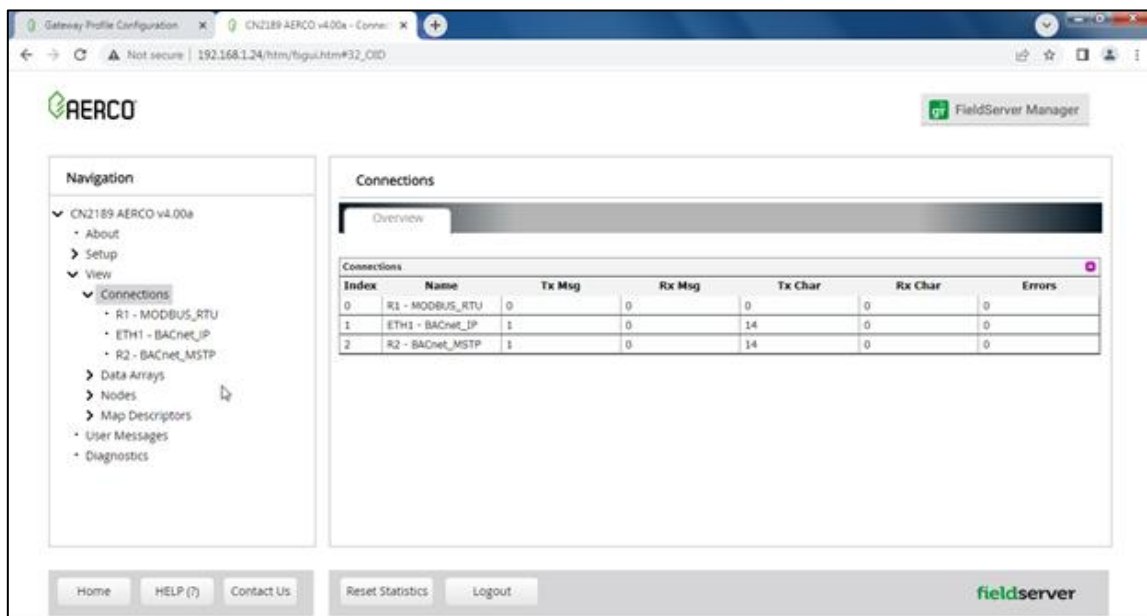

9.3. Checking Wiring and Settings

No COMS on the Serial side. If the Tx/Rx LEDs are not flashing rapidly then there is a COM issue. To fix this problem, check the following:

- Visual observations of LEDs on the ProtoAir. (Section 8.4 LED Functions)
- Check baud rate, parity, data bits, stop bits.
- Check device address.
- Verify wiring.
- Verify the device was listed in the Web Configurator (Section 6.2.2 Setting Active Profiles).

Field COM problems:

- Visual observations of LEDs on the ProtoAir. (Section 8.4 LED Functions)
- Verify wiring.
- Verify IP Address setting.

NOTE: If the problem still exists, a Diagnostic Capture needs to be taken and sent to support. (Section 8.5 Taking a FieldServer Diagnostic Capture)

9.4. LED Functions

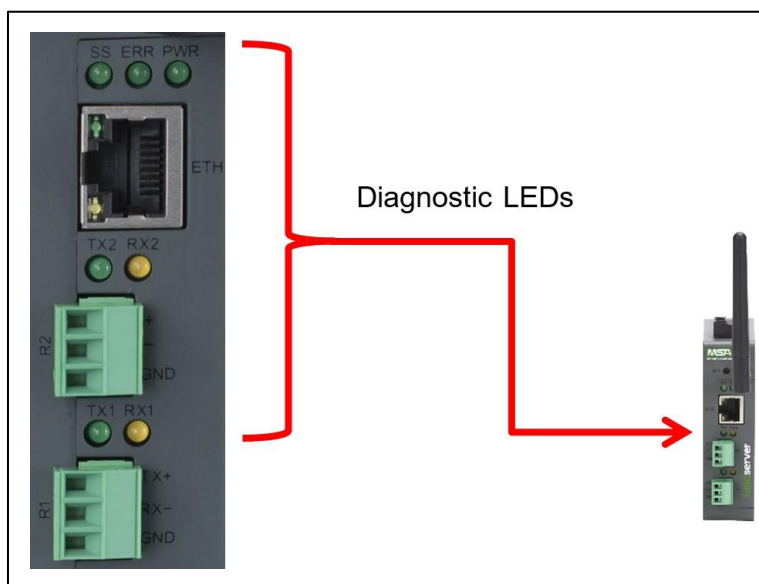

Tag	Description
SS	The SS LED will flash once a second to indicate that the bridge is in operation.
ERR	The SYS ERR LED will go on solid indicating there is a system error. If this occurs, immediately report the related “system error” shown in the error screen of the FS-GUI interface to support for evaluation.
PWR	This is the power light and should always be steady green when the unit is powered.
RX	The RX LED will flash when a message is received on the serial port on the 3-pin connector. If the serial port is not used, this LED is non-operational. RX1 applies to the R1 connection while RX2 applies to the R2 connection.
TX	The TX LED will flash when a message is sent on the serial port on the 3-pin connector. If the serial port is not used, this LED is non-operational. TX1 applies to the R1 connection while TX2 applies to the R2 connection.

9.5. Taking a FieldServer Diagnostic Capture

When there is a problem on-site that cannot easily be resolved, perform a Diagnostic Capture before contacting support. Once the Diagnostic Capture is complete, email it to technical support. The Diagnostic Capture will accelerate diagnosis of the problem.

- Access the FieldServer Diagnostics page via one of the following methods:
 - Open the FieldServer FS-GUI page and click on Diagnostics in the Navigation panel
 - Open the FieldServer Toolbox software and click the diagnose icon of the desired device

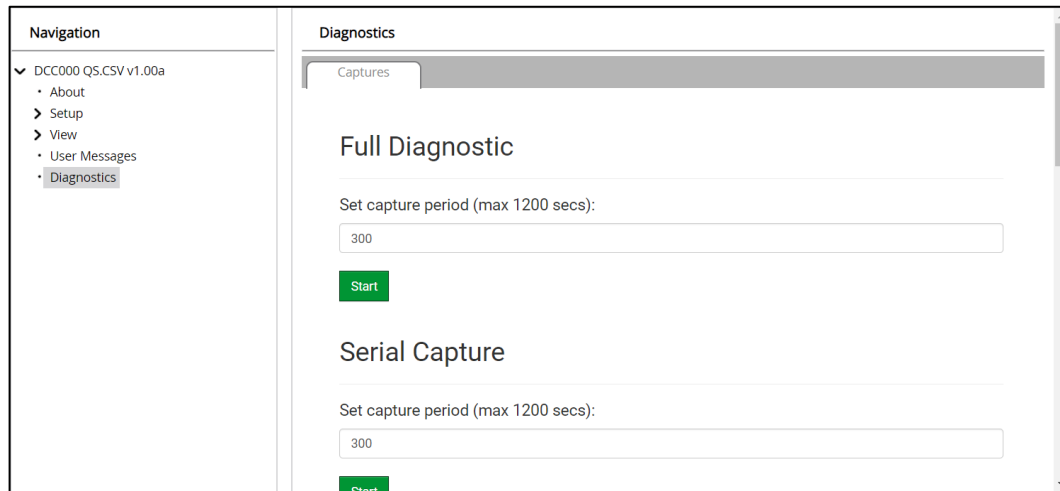

- Go to Full Diagnostic and select the capture period.
- Click the Start button under the Full Diagnostic heading to start the capture.
 - When the capture is finished, a Download button appears next to the Start button



- Click Download for the capture to be downloaded to the local PC.
- Email the diagnostic zip file to technical support (smc-support.emea@msasafety.com).

NOTE: Diagnostic captures of BACnet MS/TP communication are output in a “.PCAP” file extension which is compatible with Wireshark.

9.6. Wi-Fi Signal Strength

- <60dBm – Excellent
- <70dBm – Very good
- <80dBm – Good
- >80dBm – Weak

NOTE: If the signal is weak or spotty, try to improve the signal strength by checking the antenna and the FieldServer position.

9.7. Factory Reset Instructions

For instructions on how to reset a FieldServer back to its factory released state, see [ENOTE FieldServer Next Gen Recovery](#).

9.8. Internet Browser Software Support

The following web browsers are supported:

- Chrome Rev. 57 and higher
- Firefox Rev. 35 and higher
- Microsoft Edge Rev. 41 and higher
- Safari Rev. 3 and higher

NOTE: Internet Explorer is no longer supported as recommended by Microsoft.

NOTE: Computer and network firewalls must be opened for Port 80 to allow FieldServer GUI to function.

10. ADDITIONAL INFORMATION

10.1. Update Firmware

To load a new version of the firmware, follow these instructions:

1. Extract and save the new file onto the local PC.
2. Open a web browser and type the IP Address of the FieldServer in the address bar.
 - Default IP Address is **192.168.1.24**
 - Use the FS Toolbox utility if the IP Address is unknown (Section 8.1)
3. Click on the “Diagnostics & Debugging” button.
4. In the Navigation Tree on the left hand side, do the following:
 - a. Click on “Setup”
 - b. Click on “File Transfer”
 - c. Click on the “General” tab
5. In the General tab, click on “Choose Files” and select the “.simg” file extracted in step 1.
6. Click on the “Submit” button.
7. When the download is complete, click on the “System Restart” button.

NOTE: Contact AERCO/WATTS to receive any firmware updates.

10.2. BACnet: Setting Network_Number for More Than One ProtoAir on the Subnet

For both BACnet MS/TP and BACnet IP, if more than one ProtoAir is connected to the same subnet, they must be assigned unique Network_Number values.

On the main Web Configuration screen, update the BACnet Network Number field and click “Submit”. The default value is 50.

<code>network_nr</code>	<p>BACnet Network Number This sets the BACnet network number of the Gateway. <i>(1 - 65535)</i></p>	<input style="width: 80%;" type="text" value="50"/>	<input style="background-color: #008000; color: white; padding: 5px 10px;" type="button" value="Submit"/>
-------------------------	--	---	---

10.3. Mounting

The gateway can be mounted using the DIN rail mounting bracket on the back of the unit.



← Din Rail
Bracket

10.4.Certification

BTL Mark – BACnet Testing Laboratory



The BTL Mark on the FieldServer is a symbol that indicates that a product has passed a series of rigorous tests conducted by an independent laboratory which verifies that the product correctly implements the BACnet features claimed in the listing. The mark is a symbol of a high-quality BACnet product.

Go to www.BACnetInternational.net for more information about the BACnet Testing Laboratory. Click here for the BACnet PIC Statement. BACnet is a registered trademark of ASHRAE.

10.5.Physical Dimensions

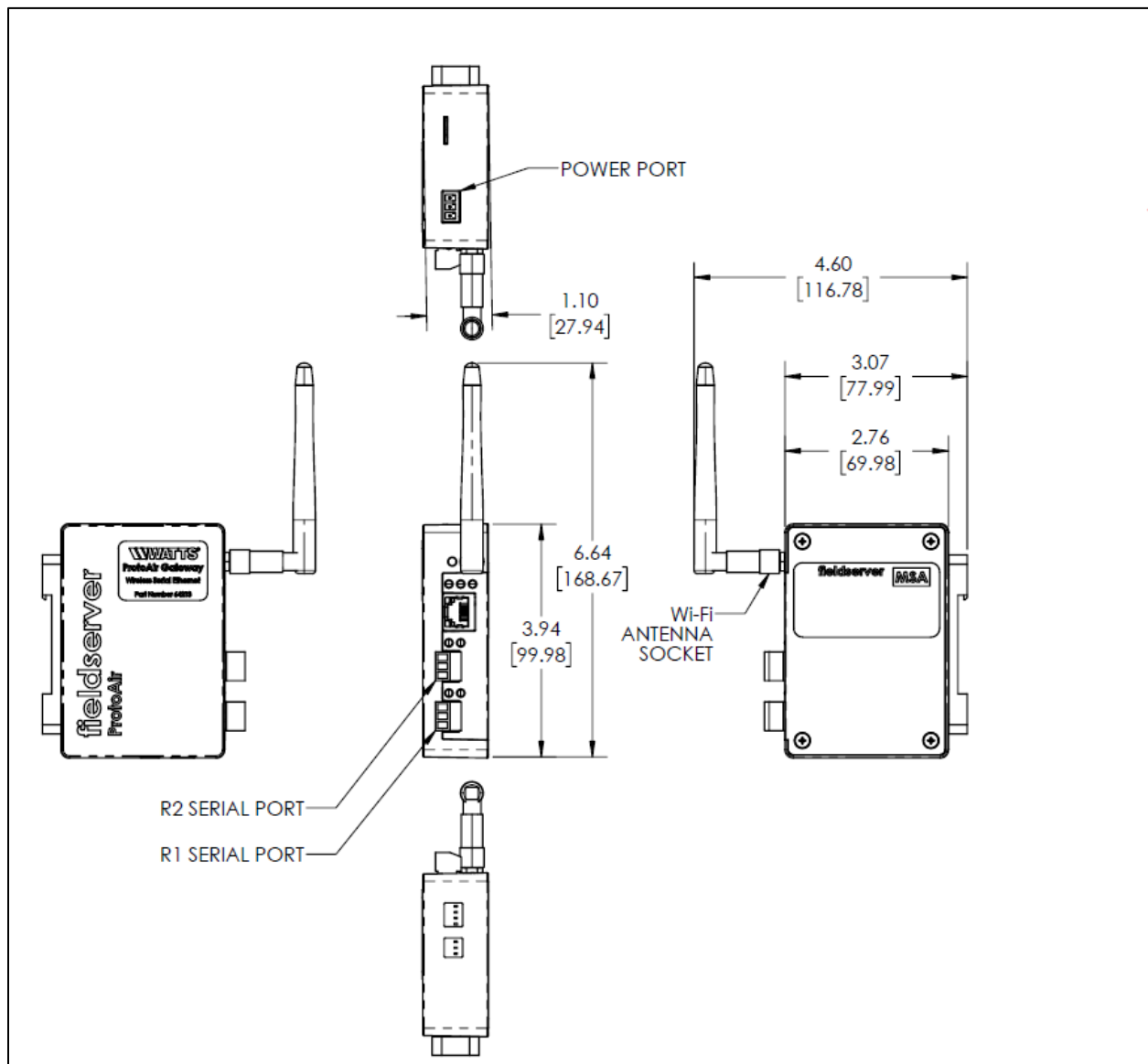

NOTE: Dimensions shown are in Inches [mm]”.

10.6. Change Web Server Security Settings After Initial Setup

- Navigate to the FS-GUI page.
- Click Setup in the Navigation panel.

NOTE: Any changes will require a FieldServer reboot to take effect.

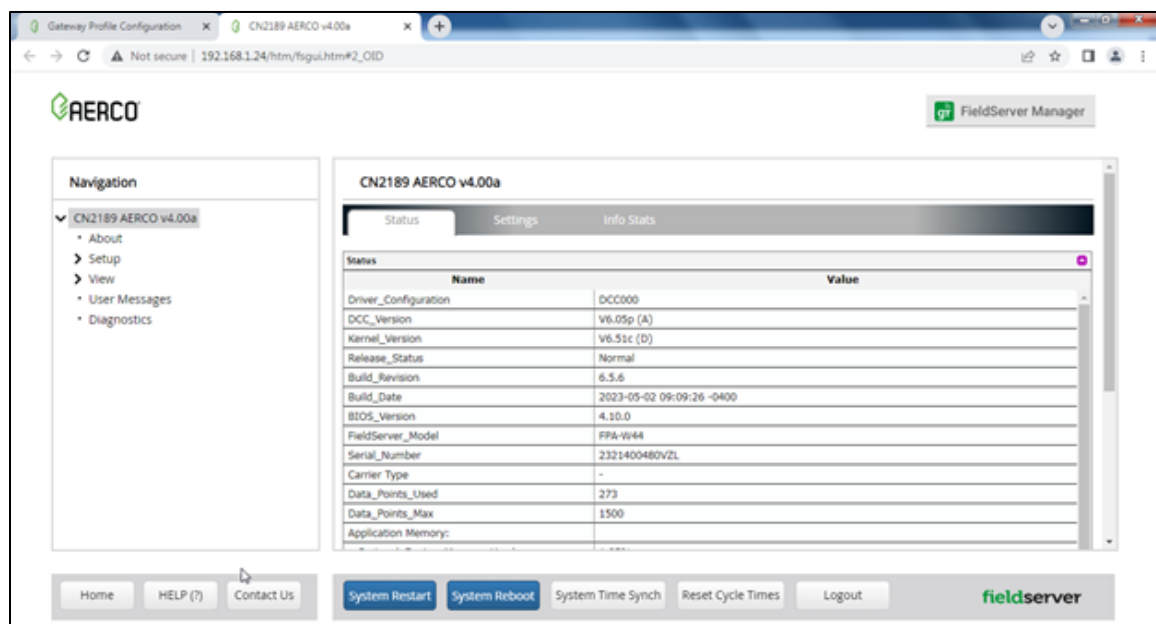

10.6.1. Change Security Mode

- Click Security in the Navigation panel.

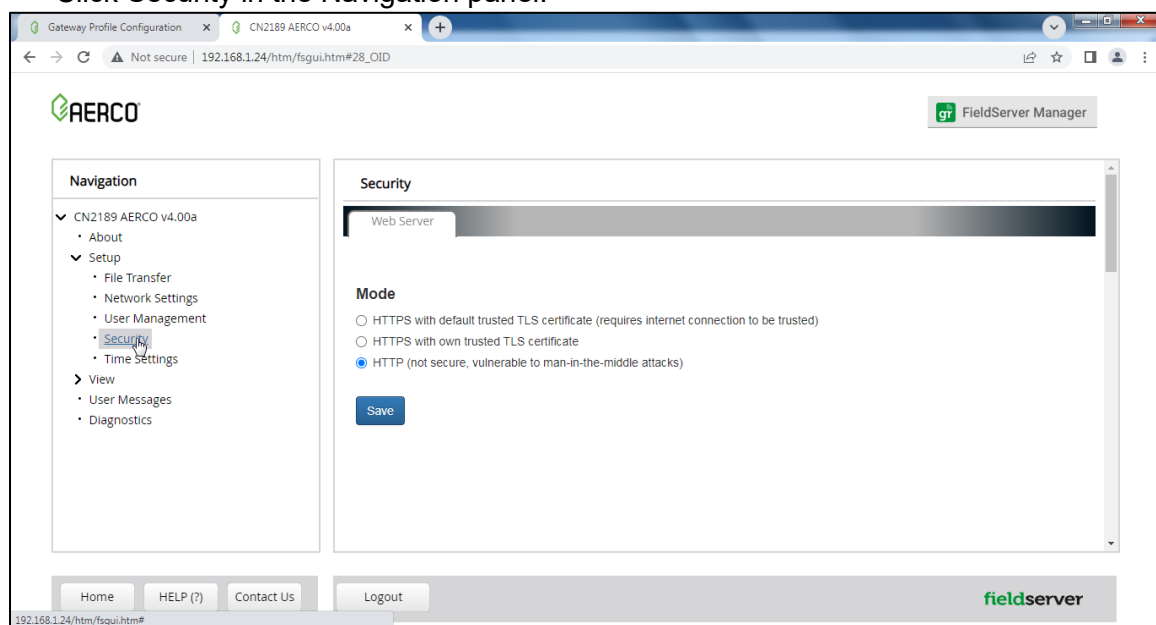

- Click the Mode desired.
 - If HTTPS with own trusted TLS certificate is selected, follow instructions in Section 5.2.1.
- Click the Save button.

10.6.2. Edit the Certificate Loaded onto the FieldServer

A loaded certificate is available if security mode was set up as HTTPS with own trusted TLS certificate.

- Click Security in the Navigation panel.

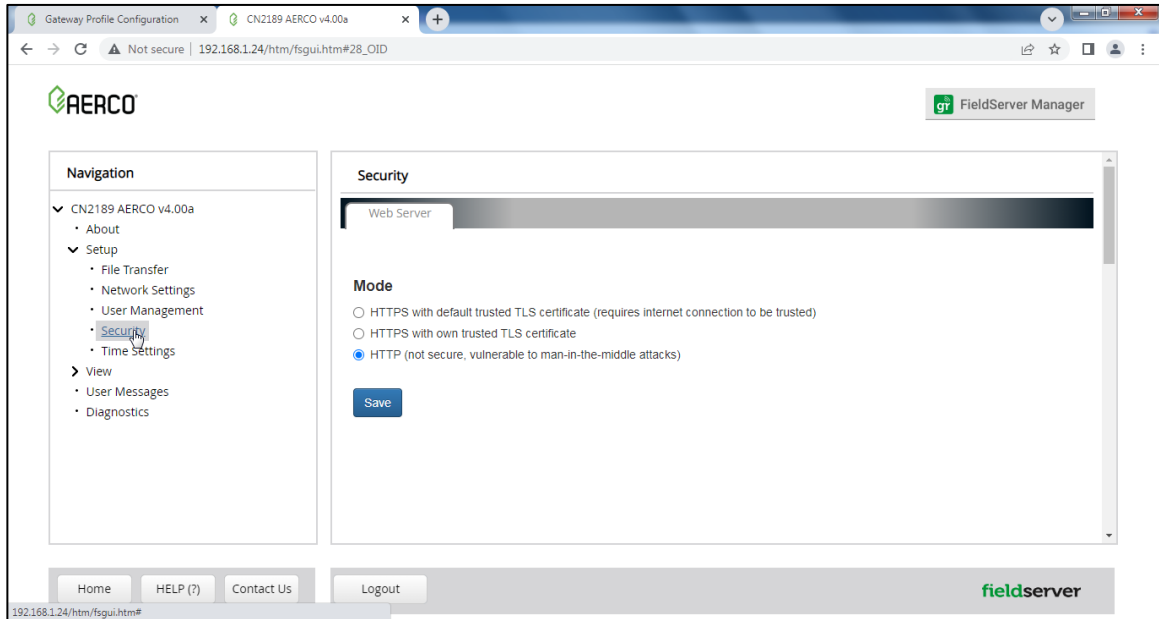

- Click the Edit Certificate button to open the certificate and key fields.
- Edit the loaded certificate or key text as needed and click **Save**.

10.7. Change User Management Settings

- From the FS-GUI page, click Setup in the Navigation panel.
- Click User Management in the navigation panel.

NOTE: If the passwords are lost, the unit can be reset to factory settings to reinstate the default unique password on the label. If the default unique password is lost, then the unit must be mailed back to the factory.

NOTE: Any changes will require a FieldServer reboot to take effect.

- Check that the Users tab is selected.

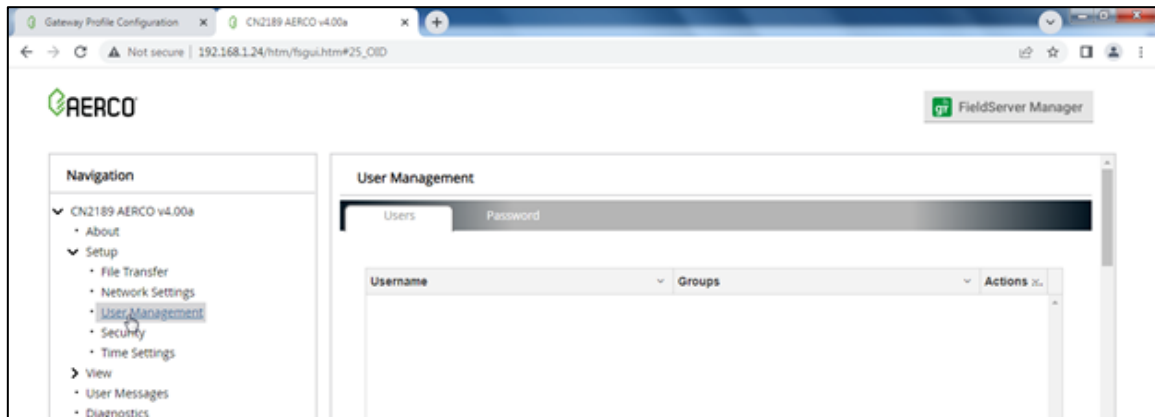

- Admin** – Can modify and view any settings on the FieldServer.
- Operator** – Can modify and view any data in the FieldServer array(s).
- Viewer** – Can only view settings/readings on the FieldServer.

10.7.1. Create Users

- Click the **Create User** button

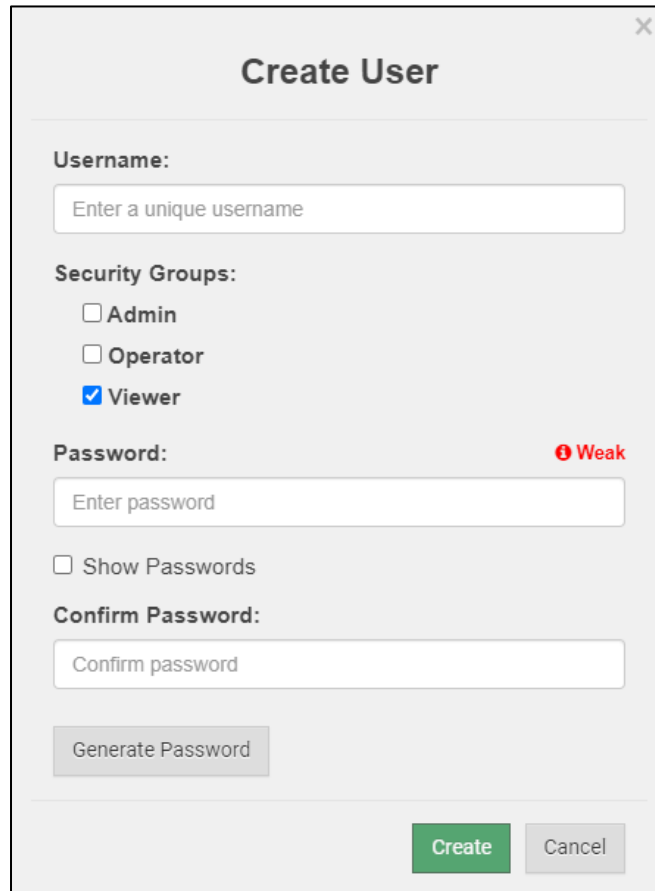

- Enter the new User fields: Name, Security Group and Password.
- User details are hashed and salted to protect login details.

NOTE: The password must meet the minimum complexity requirements. An algorithm automatically checks the password entered and notes the level of strength on the top right of the Password text field.

- Click the **Create** button.
- Once the Success message appears, click OK.

10.7.2. Edit Users

- Click the pencil icon next to the desired user to open the User Edit window.

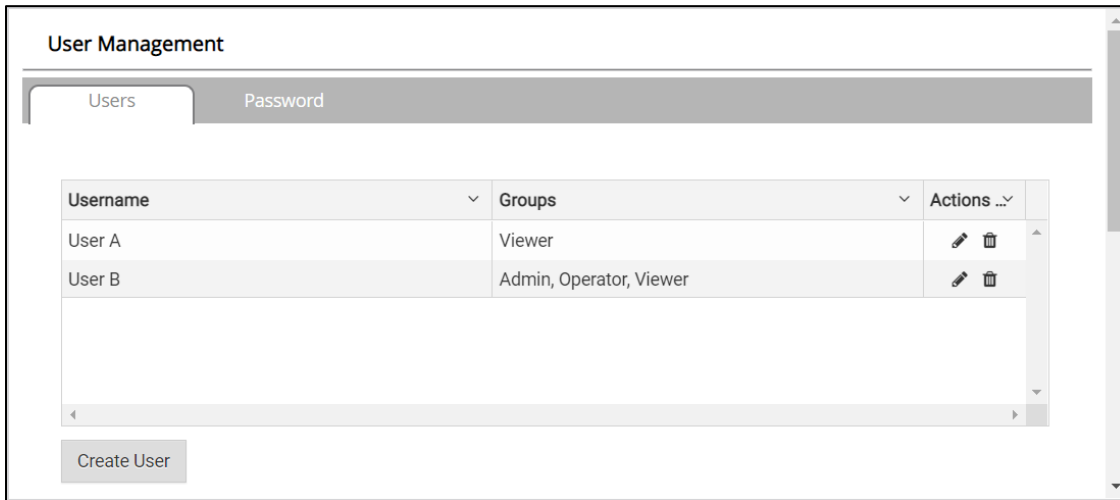

- Once the User Edit window opens, change the User Security Group and Password as needed.

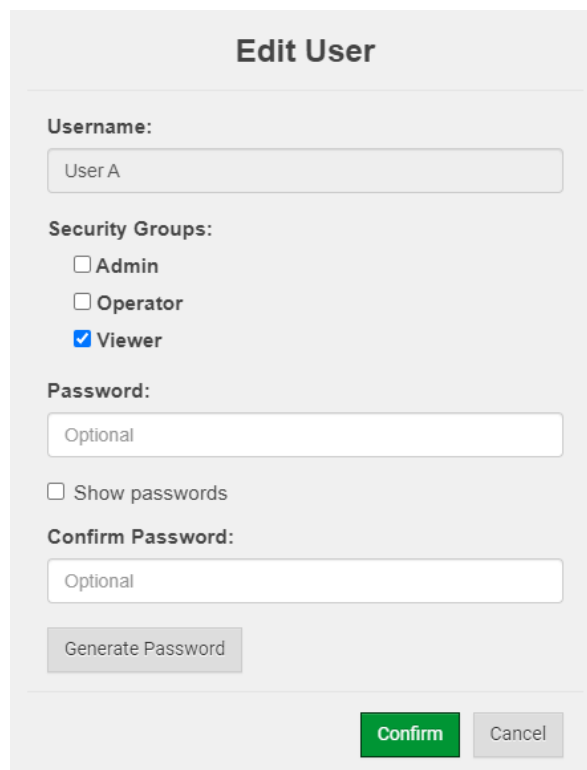

The 'Edit User' form contains the following fields and options:

- Username:** Text input field containing 'User A'.
- Security Groups:**
 - Admin
 - Operator
 - Viewer
- Password:** Text input field containing 'Optional'.
- Show passwords
- Confirm Password:** Text input field containing 'Optional'.
-
-

- Click Confirm.
- Once the Success message appears, click OK.

10.7.3. Delete Users

- Click the trash can icon next to the desired user to delete the entry.

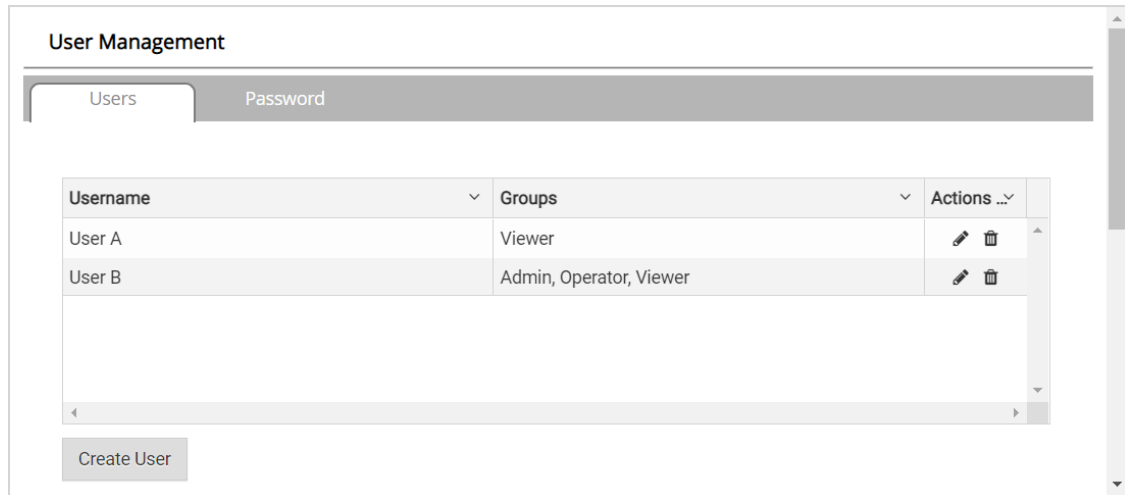

- When the warning message appears, click Confirm.

10.7.4. Change FieldServer Password

- Click the Password tab.

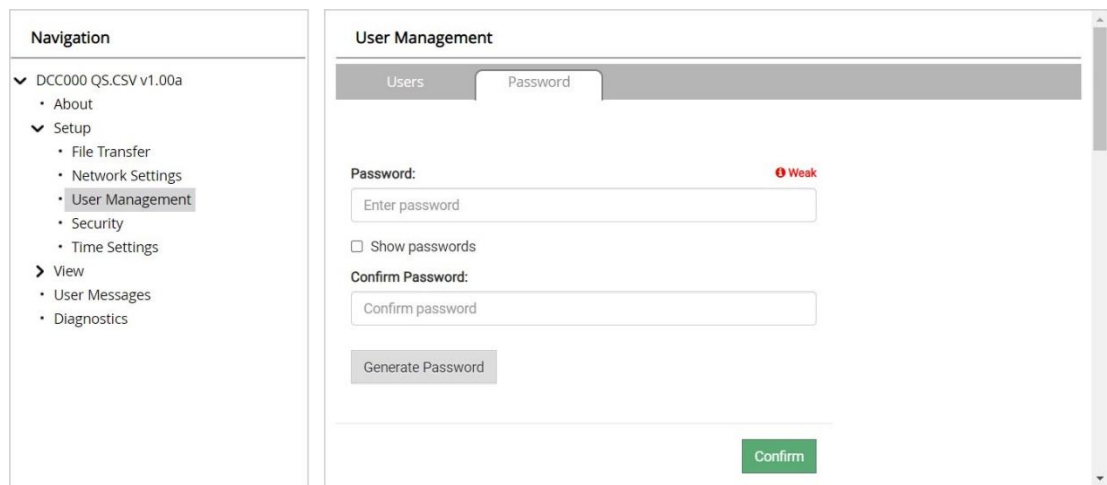

- Change the general login password for the FieldServer as needed.

NOTE: The password must meet the minimum complexity requirements. An algorithm automatically checks the password entered and notes the level of strength on the top right of the Password text field.

11. VENDOR INFORMATION – WATTS

Only the protocols listed as supported for this FieldServer are supported (see **Section 1**). Ignore all points referring to unsupported protocols when using this FieldServer.

11.1.AERCO/WATTS Equipment Points Mapping

11.1.1. AERCO C-More & ACS/BMS II/BMS Point Definitions

Point Name	BAS Modbus Data Address	GF-108, GF-124, GF-114 Point Name	Reg. Type	Modbus Data Address (Hex/Dec.)	Units (Range)
C-More (similar for Edge)					
Fire Rate Out	30009	Fire Rate Out	Input	0x0008 / 8	% (0 to 100)
Active Setpoint	30017	Active Set Point	Input	0x0010 / 16	deg F (40 to 220)
Net Remote Setpt	40001	Net Remote Set Point	Holding	0x0000 / 0	deg F (40 to 220)
*Net Direct Drive	40002	Net Direct Drive	Holding	0x0001 / 1	% (0 to 100)
Fire Rate In	30018	Fire Rate In	Input	0x0011 / 17	% (0 to 100)
Outlet Temp	30003	Outlet Temp	Input	0x0002 / 2	deg F (30 to 245)
Display Code	30001	Default Message Display Code	Input	0x0000 / 0	Enum (1 to 102) See Appendix F
Unit Status	30002	Unit Status	Input	0x0001 / 1	Enum (0 to 5) 0 = Disabled 1 = Standby 2 = Manual Operation 3 = Remote Operation 4 = Auto Operation (Constant Setpoint) 5 = Fault
Run Cycles	30012-30013	Run Cycles	Input	0x000B - 0x000C / 11 - 12	(0 to 999,999) Cmore (0 to 999,999,999) Edge
Run Hours	30014-30015	Run Hours	Input	0x000D - 0x000E / 13 - 14	(0 to 999,999) Cmore (0 to 999,999,999) Edge
Oxygen	30010	O2 Level	Input	0x0009 / 9	% (0 to 25) (Value x 10)
Exhaust Temp	30007	Exhaust Temp	Input	0x0006 / 6	Deg F (50 to 550)

* Where available in special profiles

ACS/BMS II/BMS					
Fire Rate Out	30005	Fire Rate Out	Input	0x0004 / 4	% (0 to 100)
Header Set Temp	30006	Header Set Temperature	Input	0x0005 / 5	°F (40 to 220)
Net Header Set Temp	40005	Net Header Set Temp	Holding	0x0004 / 4	°F (40 to 220)
Header Temp	30002	Header Temperature	Input	0x0001 / 1	°F (40 to 220)
Outside Air Temp	30003	Outside Air Temperature	Input	0x0002 / 2	°F (-60 to 120)

Point Name	BAS Modbus Data Address	GF-108, GF-124, GF-114 Point Name	Reg. Type	Modbus Data Address (Hex/Dec.)	Units (Range)
Display Code	30011	Fault/Message Code	Input	0x000A / 10	Bit (0 to 65535) Bit 0 = Outside Air Sensor Error Bit 1 = Header Sensor Error Bit 2 = Interlock 1 Error Bit 3 = Interlock 2 Error Bit 4 = Indoor Air/Return Sens Error Bit 5 = 4-20 mA Input Error
Num Boilers Fired	30008	Total Boilers Fired	Input	0x0007 / 7	(0 to 40) BMS (0 to 32) BMSII, ACS
Num Boilers Online	30009	Total Boilers On Line	Input	0x0008 / 8	(0 to 40) BMS (0 to 32) BMSII, ACS
Last Blr Fired	30017	Last Boiler Fired	Input	0x0010 / 16	(1 to 40) BMS (1 to 32) BMSII, ACS
Boiler 1 Status	30018	Boiler 1 Status (PWM Boiler 1)	Input	0x0011 / 17	Enum (1 to 40, 119, 120) 1 to 40 = Fired and Sequence 119 = Not On Line 120 = On Line But Not Fired
Boiler 2 Status	30019	Boiler 2 Status (PWM Boiler 2)	Input	0x0012 / 18	Same As Above
Boiler 3 Status	30020	Boiler 3 Status (PWM Boiler 3)	Input	0x0013 / 19	Same As Above
Boiler 4 Status	30021	Boiler 4 Status (PWM Boiler 4)	Input	0x0014 / 20	Same As Above
Boiler 5 Status	30022	Boiler 5 Status (PWM Boiler 5)	Input	0x0015 / 21	Same As Above
Boiler 6 Status	30023	Boiler 6 Status (PWM Boiler 6)	Input	0x0016 / 22	Same As Above
Boiler 7 Status	30024	Boiler 7 Status (PWM Boiler 7)	Input	0x0017 / 23	Same As Above
Boiler 8 Status	30025	Boiler 8 Status (PWM Boiler 8)	Input	0x0018 / 24	Same As Above
Net Blr 1 Status	30026	Net Boiler 1	Input	0x0019 / 25	Enum (1 to 40, 119, 120) 1 to 40 = Fired and Sequence 119 = Not On Line 120 = On Line But Not Fired 121 = On Line But Disabled 122 = On Line But Faulted
Net Blr 2 Status	30027	Net Boiler 2	Input	0x001A / 26	Same As Above
Net Blr 3 Status	30028	Net Boiler 3	Input	0x001B / 27	Same As Above
Net Blr 4 Status	30029	Net Boiler 4	Input	0x001C / 28	Same As Above
Net Blr 5 Status	30030	Net Boiler 5	Input	0x001D / 29	Same As Above
Net Blr 6 Status	30031	Net Boiler 6	Input	0x001E / 30	Same As Above
Net Blr 7 Status	30032	Net Boiler 7	Input	0x001F / 31	Same As Above
Net Blr 8 Status	30033	Net Boiler 8	Input	0x0020 / 32	Same As Above

Point Name	BAS Modbus Data Address	GF-108, GF-124, GF-114 Point Name	Reg. Type	Modbus Data Address (Hex/Dec.)	Units (Range)
Net Blr 9 Status	30034	Net Boiler 9	Input	0x0021 / 33	Same As Above
Net Blr 10 Status	30035	Net Boiler 10	Input	0x0022 / 34	Same As Above
Net Blr 11 Status	30036	Net Boiler 11	Input	0x0023 / 35	Same As Above
Net Blr 12 Status	30037	Net Boiler 12	Input	0x0024 / 36	Same As Above
Net Blr 13 Status	30038	Net Boiler 13	Input	0x0025 / 37	Same As Above
Net Blr 14 Status	30039	Net Boiler 14	Input	0x0026 / 38	Same As Above
Net Blr 15 Status	30040	Net Boiler 15	Input	0x0027 / 39	Same As Above
Net Blr 16 Status	30041	Net Boiler 16	Input	0x0028 / 40	Same As Above
Net Blr 17 Status	30042	Net Boiler 17	Input	0x0029 / 41	Same As Above
Net Blr 18 Status	30043	Net Boiler 18	Input	0x0030 / 42	Same As Above
Net Blr 19 Status	30044	Net Boiler 19	Input	0x0031 / 43	Same As Above
Net Blr 20 Status	30045	Net Boiler 20	Input	0x0032 / 44	Same As Above
Net Blr 21 Status	30046	Net Boiler 21	Input	0x0033 / 45	Same As Above
Net Blr 22 Status	30047	Net Boiler 22	Input	0x0034 / 46	Same As Above
Net Blr 23 Status	30048	Net Boiler 23	Input	0x0035 / 47	Same As Above
Net Blr 24 Status	30049	Net Boiler 24	Input	0x0036 / 48	Same As Above
Net Blr 25 Status	30050	Net Boiler 25	Input	0x0037 / 49	Same As Above
Net Blr 26 Status	30051	Net Boiler 26	Input	0x0038 / 50	Same As Above
Net Blr 27 Status	30052	Net Boiler 27	Input	0x0039 / 51	Same As Above
Net Blr 28 Status	30053	Net Boiler 28	Input	0x0040 / 52	Same As Above
Net Blr 29 Status	30054	Net Boiler 29	Input	0x0041 / 53	Same As Above
Net Blr 30 Status	30055	Net Boiler 30	Input	0x0042 / 54	Same As Above
Net Blr 31 Status	30056	Net Boiler 31	Input	0x0043 / 55	Same As Above
Net Blr 32 Status	30057	Net Boiler 32	Input	0x0044 / 56	Same As Above
Return Temp	30059	Return Sensor Temp	Input	0x0045 / 58	°F (40 to 220)
Input Output Status	30058	I/O Status	Input	0x0039 / 57	Bit 0 = Aux Relay Status Bit 1 = Fault Relay Status Bit 2 = Sys Start Relay Status Bit 3 = Not Used Bit 4 = Setback Status Bit 5 = Interlock 2 Status Bit 6 = Interlock 1 Status Bit 7 = Not Used

11.1.2. AERCO Electronic Control System (ECS) Point Definitions

Point Name	BAS Modbus Data Address	GF-108, GF-124, GF-114 Point Name	Reg. Type	Modbus Data Address (Hex/Dec.)	Units (Range)
Electric Valve (ECS) and SmartPlate					
Cntl Output Signal	30004	OP (Control Output Signal)	Input	0x0003 / 3	% (0 to 100)
Setpoint	30006	w.SP (Setpoint)	Input	0x0005 / 5	°F (40 to 180)
RmSetpt	40027	Remote Input Comms Access parameter(Setpoint)	Holding	0x001A / 26	°F (40 to 180)
Outlet Temp	30002	Top Value (Outlet Temp)	Input	0x0001 / 1	°F (40 to 205)
FBk Sensor Temp	30290	Li1 (Feedback Sensor Temp)	Input	0x0121 / 289	°F (40 to 180)
Over Temp Alarm	30075	AL 1 (Over Temp Alarm)	Input	0x004A / 74	Bit 0 = Alarm 1 State (0 = Safe 1 = Alarm). Bit 1 = Alarm 2 State (0 = Safe 1 = Alarm). Bit 2 = Alarm 3 State (0 = Safe 1 = Alarm). Bit 3 = Alarm 4 State (0 = Safe 1 = Alarm). Bit 4 = Manual Mode (0 = Auto 1 = Manual). Bit 5 = Sensor Break (0 = Good PV 1 = Sensor Broken). Bit 6 = Loop Break (0 = Good closed loop 1 = Open Loop). Bit 7 = Heater Fail (0 = No Fault 1 = Load fault detected).
Flow Rate /Mixed Temp	30291	Li2 (Flow)	Input	0x0122 / 290	GPM or F (40 to 205)
Alt Set Point	40486	Altsetpt	Holding	0x01E5 / 485	°F (40 to 180)

11.1.3. Standalone SmartPlate EV Points

Point Name	BACnet Address	Lon Name	Lon SNVT	Modbus Reg Type	Modbus Data Addresses	Unit Range
SmartPlate EV						
DHW Out	AV: 1	nvoSPEVDhwOut_XXX	SNVT_count_inc	Input	1	°F (40 to 220)
Setpoint	AV: 2	nviSPEVSetpoint_XXX	SNVT_count_inc	Holding	2	°F (40 to 180)
Valve POS	AV: 4	nvoSPEVValvePOS_XXX	SNVT_count_inc	Input	4	% (0-100)
DHW Flow	AV: 364	nvoSPEVDhwFlow_XXX	SNVT_count_inc	Input	364	GPM (0-150)
BW Inlet T	AV: 370	nvoSPEVBWInlet_T_XXX	SNVT_count_inc	Input	370	°F (40 to 220)
DHW Inlet T	AV: 373	nvoSPEVDhwInlet_T_XXX	SNVT_count_inc	Input	373	°F (40 to 220)
DP	AV: 379	nvoSPEVDP_XXX	SNVT_count_inc	Input	379	PSI (0 to 100)
Alarm 1 Out	AV: 10249	nvoSPEVAlarm1Out_XXX	SNVT_count_f	Input	10249	
Alarm 2 Out	AV: 10265	nvoSPEVAlarm2Out_XXX	SNVT_count_f	Input	10265	
Alarm 3 Out	AV: 10281	nvoSPEVAlarm3Out_XXX	SNVT_count_f	Input	10281	
Alarm 4 Out	AV: 10297	nvoSPEVAlarm4Out_XXX	SNVT_count_f	Input	10297	
Alarm 5 Out	AV: 10313	nvoSPEVAlarm5Out_XXX	SNVT_count_f	Input	10313	
Alarm 6 Out	AV: 10329	nvoSPEVAlarm6Out_XXX	SNVT_count_f	Input	10329	
Alarm 7 Out	AV: 10345	nvoSPEVAlarm7Out_XXX	SNVT_count_f	Input	10345	
Alarm 8 Out	AV: 10361	nvoSPEVAlarm8Out_XXX	SNVT_count_f	Input	10361	

11.1.4. AERCO (Modulex) BCM Point Definitions

Point Name	BAS Modbus Data Address	GF-108, GF-124, GF-114 Point Name	Reg. Type	Modbus Data Address (Hex/Dec.)	Units (Range)
Modulux Boiler with BCM					
Act Mod Lev (Actual Modulation Level)	41009	Global Actual Modulation Level	Holding	0x03F0 / 1008	% (0 to 100)
Target Setpoint	41019	Target Setpoint	Holding	0x03F8 / 1016	°F (32 to 185) (Value x 10)
Req Outlet Temp (Requested Outlet Temp)	41005	Requested Setpoint	Holding	0x03EC / 1004	°F (32 to 185) (Value x 10)
Net Direct Drive	40002	Direct Drive Requested Modulation Level	Holding	0x0001 / 1	% (0 to 100)
Mod Lev In (Modulation Level In)	41201	Monitor Only Global Modulation Level from Cascade Manager	Holding	0x04B0 / 1200	% (0 to 100)
Flow Sens Temp (Flow Sensor Temperature)	41003	Flow Sensor Temperature	Holding	0x03EA / 1002	°F (14 to 212) (Value x 10)
Display Code	30001	Status & Error Code (C-more compatible)	Input	0x0000 / 0	Enum (2,8,10,18,23,32,38,42) 2 = Standby 8 = High Temp Switch Open 10 = Low Gas Press Switch Open 18 = Air Flow Switch Open During Ignition 23 = Flame Loss During Run 32 = Residual Flame 38 = Other Conditions Not Listed 42 = Outlet (Flow) Temp Sensor Fault
Error Code	40001	Error Code	Holding	0x0000 / 0	(0 to 0xFFFF) LSB = Error Code MSB = Id Code Of Fault Device (0 = BMM#0, 7 = BMM#7, 255 = BCM). See Appendix B.
Unit Status	30002	Unit Status (C-more Compatible)	Input	0x0001 / 1	Enum (1,3,5) 1 = Standby (ready to run but not fired) 3 = Fired 5 = Fault
Ret Flow Temp (Return Flow Temperature)	41004	Return Flow Temperature	Holding	0x03EB / 1003	°F (32 to 212) (Value x 10)

NOTE: See Appendix B-1 for the ACS/BMS II point definitions.

IMPORTANT:

Some Modbus addresses specified in this manual are written generically in hexadecimal/decimal format. However, many Building Automation Systems utilize another form of addressing where:

- 40001 is added to the generic address for a Holding Register address.
- 30001 is added to the generic address for an Input Register address.

Check the addressing scheme being used by the BAS interfaced to the ProtoAir.

11.1.5. WHM and On-Board BST Point Definitions

Water Heater Management System and On-Board Boiler Sequencing Technology Point Definitions

Point Name	BAS Modbus Data Address	GF-108, GF-124, GF-114 Point Name	Reg. Type	Modbus Data Address (Dec.)	Units (Range)
WHM or BST Master					
Write Control to WHM/BST	40051	SMD_BAS_IP_Ctrl_[1]	Holding	50	Write "1" to send value to WHM/BST
Read Timeout	40053	SMD_BAS_IP_Ctrl_[3]	Holding	52	0 to
Read Mode	30100	SMD_BAS_IP_OpVal_[0]	Input	99	0 = OFF, 1 = Slave, 2 = Master
Read Setpoint	30101	SMD_BAS_IP_OpVal_[1]	Input	100	°F (40 to 200)
Read Setback Setpoint	30102	SMD_BAS_IP_OpVal_[2]	Input	101	°F (40 to 200)
Read Setback Time Start	30103	SMD_BAS_IP_OpVal_[3]	Input	102	12:00 AM to 11:59 PM (see note)
Read Setback Time End*	30104	SMD_BAS_IP_OpVal_[4]	Input	103	12:00 AM to 11:59 PM (see note)
Read Auto Master Status	30105	SMD_BAS_IP_OpVal_[5]	Input	104	0 = NO, 1 = YES
Read Average Outlet Temp.	30106	SMD_BAS_IP_OpVal_[6]	Input	105	°F (30 to 245)
Read # Units Active	30107	SMD_BAS_IP_OpVal_[7]	Input	106	0 to 8 (Cmore), 0 to 16 (Edge)
Read # Units Faulted	30108	SMD_BAS_IP_OpVal_[8]	Input	107	0 to 8 (Cmore), 0 to 16 (Edge)
Read Master Address	30109	SMD_BAS_IP_OpVal_[9]	Input	108	0, 17-250
Header Temp	30110	SMD_BAS_IP_OpVal_[10]	Input	109	°F (30 to 245)
Outdoor Temp	30111	SMD_BAS_IP_OpVal_[11]	Input	110	°F (-70 to 130)
Percent Output	30112	SMD_BAS_IP_OpVal_[12]	Input	111	% (0 to 100)
Number of Units Firing	30113	SMD_BAS_IP_OpVal_[13]	Input	112	0 to 8 (Cmore), 0 to 16 (Edge)
Master Active Setpoint	30114	SMD_BAS_IP_OpVal_[14]	Input	113	°F (40 to 220)
Next Turn-On Percent	30115	SMD_BAS_IP_OpVal_[15]	Input	114	% (16 to 100)
Header High Limit	30116	SMD_BAS_IP_OpVal_[16]	Input	115	°F (Header Low Limit to 220)
Header Low Limit	30117	SMD_BAS_IP_OpVal_[17]	Input	116	°F (40 to Header High Limit)
Header Temp High Limit	30118	SMD_BAS_IP_OpVal_[18]	Input	117	°F (40 to 220)
Header Setpoint Mode	30119	SMD_BAS_IP_OpVal_[19]	Input	118	Number List (0 to 2) 0 = Constant Setpoint 1 = Remote Setpoint 2 = Outdoor Reset
Write Setpoint	40200	SMD_BAS_IP_CtrlVal_[0]	Holding	199	°F (40 to 200)
Write Setback Setpoint	40201	SMD_BAS_IP_CtrlVal_[1]	Holding	200	°F (40 to 200)
Write Setback Time Start	40202	SMD_BAS_IP_CtrlVal_[2]	Holding	201	12:00 AM to 11:59 PM
Write Setback Time End	40203	SMD_BAS_IP_CtrlVal_[3]	Holding	202	12:00 AM to 11:59 PM
WHM Heater or BST Boiler					
Communication Address	3xx00	SMD_BAS_IP_HTR_(xx-2)_[0]	Input	(xx00-1)	0 to 16
Unit Status	3xx01	SMD_BAS_IP_HTR_(xx-2)_[1]	Input	xx00	Enum List (0 to 5) 0 = Disabled 1 = Standby 2 = Manual Operation 3 = Remote Operation 4 = Auto Operation 5 = Fault
Fault Code	3xx02	SMD_BAS_IP_HTR_(xx-2)_[2]	Input	xx01	Fault codes 0-102 matching the C-More fault codes.
Outlet Temperature	3xx03	SMD_BAS_IP_HTR_(xx-2)_[3]	Input	xx02	°F (30 to 245)
FFWD Temperature	3xx04	SMD_BAS_IP_HTR_(xx-2)_[4]	Input	xx03	°F (30 to 245)
Inlet Temperature	3xx05	SMD_BAS_IP_HTR_(xx-2)_[5]	Input	xx04	°F (30 to 245)
Exhaust Temperature	3xx06	SMD_BAS_IP_HTR_(xx-2)_[6]	Input	xx05	°F (50 to 550)
Inlet Air Temperature	3xx07	SMD_BAS_IP_HTR_(xx-2)_[7]	Input	xx06	°F (-70 to 245)
Flame Strength	3xx08	SMD_BAS_IP_HTR_(xx-2)_[8]	Input	xx07	% (0 to 100)
Fire Rate IN	3xx09	SMD_BAS_IP_HTR_(xx-2)_[9]	Input	xx08	% (0 to 100)
Fire Rate OUT	3xx10	SMD_BAS_IP_HTR_(xx-2)_[10]	Input	xx09	% (0 to 100)
Unit Type	3xx11	SMD_BAS_IP_HTR_(xx-2)_[11]	Input	xx10	Enum List (0 to 10) (see note)
Unit Size	3xx12	SMD_BAS_IP_HTR_(xx-2)_[12]	Input	xx11	Enum List (0 to 21) (see note)

Water Heater Management System and On-Board Boiler Sequencing Technology Point Definitions

Point Name	BAS Modbus Data Address	GF-108, GF-124, GF-114 Point Name	Reg. Type	Modbus Data Address (Dec.)	Units (Range)
Valve State	3xx13	SMD_BAS_IP_HTR_(xx-2)_[13]	Input	xx12	0 = Closed , 1 = Open
Net Remote Setpoint	3xx14	SMD_BAS_IP_HTR_(xx-2)_[14]	Input	xx13	°F (40 to 200)
Run Cycles Upper 16 bits	3xx15	SMD_BAS_IP_HTR_(xx-2)_[15]	Input	xx14	0 to 65535 (see note)
Run Cycles Lower 16 bits	3xx16	SMD_BAS_IP_HTR_(xx-2)_[16]	Input	xx15	0 to 65535 (see note)
Run Hours Upper 16 bits	3xx17	SMD_BAS_IP_HTR_(xx-2)_[17]	Input	xx16	0 to 65535 (see note)
Run Hours Lower 16 bits	3xx18	SMD_BAS_IP_HTR_(xx-2)_[18]	Input	xx17	0 to 65535 (see note)
Oxygen Level	3xx19	SMD_BAS_IP_HTR_(xx-2)_[19]	Input	xx18	% (0 to 25) (Value x 10)

IMPORTANT: For WHM and BST, use the SSD profiles.

NOTE: For WHM Heater or BST Boiler:

- #1, 'xx' = 03 #2, 'xx' = 04 #3, 'xx' = 05 #4, 'xx' = 06 #5, 'xx' = 07
- #6, 'xx' = 08 #7, 'xx' = 09 #8, 'xx' = 10 #9, 'xx' = 11 #10, 'xx' = 12
- #11, 'xx' = 13 #12, 'xx' = 14 #13, 'xx' = 15 #14, 'xx' = 16 #15, 'xx' = 17
- #16, 'xx' = 18

Time: Time is expressed in minutes since midnight. For example, 360 equals 6 AM.

Run Cycles and Run Hours Example:

Run Cycles = Run Cycles Upper 16 bits * 65536 + Run Cycles Lower 16 bits
 Run Hours = Run Hours Upper 16 bits * 65536 + Run Hours Lower

SmartPlate EV Points as a part of BST:

Point Name	BACnet Address	Lon Name	Lon SNVT	Modbus Reg. Type	Modbus Data Address	Units (Range)
SP Outlet	AV: xx00	nvoSPHTR_yy_1	SNVT_count_inc	Input	3xx00	°F (30 to 245)
SP Valve Position	AV: xx01	nvoSPHTR_yy_2	SNVT_count_inc	Input	3xx01	% (0 to 100)
SP Setpoint	AV: xx02	nvoSPHTR_yy_3	SNVT_count_inc	Input	3xx02	°F (30 to 245)
SP Error #	AV: xx03	nvoSPHTR_yy_4	SNVT_count_inc	Input	3xx03	Error # 0-20
SP Delta Pres	AV: xx04	nvoSPHTR_yy_5	SNVT_count_inc	Input	3xx04	PSI (0 to 100)
SP DHW Inlet	AV: xx05	nvoSPHTR_yy_6	SNVT_count_inc	Input	3xx05	°F (-70 to 245)
SP Flow	AV: xx06	nvoSPHTR_yy_7	SNVT_count_inc	Input	3xx06	GPM (0 to 200)
SP Boiler Inlet	AV: xx07	nvoSPHTR_yy_8	SNVT_count_inc	Input	3xx07	°F (30 to 245)

In this chart “xx” begins at 35 and “yy” begins at 50. “xx” = 35 for Smartplate (SP) at address 50; “xx” = 36 for Smartplate at address 51; and so on.

SmartPlate Boiler Address #50, 'xx' = 35; #51, 'xx' = 36; #52, 'xx' = 37; #53, 'xx' = 38;
 #54, 'xx' = 39; #55, 'xx' = 40

Unit Types for Boilers /Water Heaters	
C-More Units	Edge Units
1 = KC Boiler LN	0 = KC Boiler
2 = BMK Boiler Std	1 = KC Boiler LN
3 = BMK Blr Std Dual	2 = BMK Boiler Std
4 = BMK Boiler LN	3 = BMK Blr Std Dual
5 = BMK Blr LN Dual	4 = BMK Boiler LN
6 = KC Water Heater	5 = BMK Blr LN Dual
7 = KC Wtr Heater LN	6 = KC Water Heater
8 = Innovation WH	7 = KC Wtr Heater LN
	8 = Innovation WH
	9 = Innovation N
	10 = Rockland

Unit Sizes	
C-More Units	Edge Units
1 = 600 MBH	1 = Spare
2 = 800 MBH	2 = 600 MBH – Water Heaters
3 = 1060 MBH	3 = 800 MBH – Water Heaters
4 = 1350 MBH	4 = 1060 MBH – Water Heaters
5 = 600 MBH	5 = 1350 MBH – Water Heaters
6 = 800 MBH	6 = 2000 MBH – Water Heaters
7 = 1060 MBH	0 = Spare – Boilers
8 = 1350 MBH	1 = 600 MBH – Boilers
9 = 500 MBH	2 = 800 MBH – Boilers
10 = 750 MBH	3 = 1060 MBH – Boilers
11 = 1000 MBH	4 = 1350 MBH – Boilers
12 = 1.5 MBTU	5 = 500 MBH – Boilers
13 = 1500 MBH	6 = 750 MBH – Boilers
14 = 2.0 MBTU	7 = 1000 MBH – Boilers
15 = 2000 MBH	8 = 1.5 MBTU – Boilers
16 = 2500 MBH	9 = 1500 MBH – Boilers
17 = 3.0 MBTU	10 = 2.0 MBTU – Boilers
18 = 3000 MBH	11 = 2000 MBH – Boilers
19 = 4000 MBH	12 = 2500 MBH – Boilers
20 = 5000 MBH	13 = 3.0 MBTU – Boilers
21 = 6000 MBH	14 = 3000 MBH – Boilers
	15 = 4000 MBH – Boilers
	16 = 5000 MBH – Boilers
	17 = 6000 MBH – Boilers

11.1.6. AM Series Point Definitions

For all devices, empty or not, available holding registers return 0. When it is not implemented, requests can be ignored by the Modbus device.

Holding registers below 99 are reserved for legacy devices, and are optional. The functionality of these registers is not changed or influenced by this specification.

Table 1: AM Managing Boiler Parameters

Holding Register		Access		Parameter Name	Automatic Conversion	Range
		R	W			
99	0063	X	X	Control Register	-	Bit 0: Write Enable, Bit 14: Controller Reset
100	0064	X	X	Modbus Units	-	Bit0: °C / °F Bit1: bar / psi
101	0065	X	-	Device type	-	1 = Managing / Stand-alone Boiler
102	0066	X	-	State	-	See state table
103	0067	X	-	Status	-	See status table
104	0068	X	-	Error Code	-	See error list
105	0069	X	-	Warning Code	-	See warning list
106	006A	X	X	Boiler CH setpoint	V	Depending on units °C / °F NOTE: Holding Register 106 is only valid when holding register 110 is set equal to 0 (constant setpoint).
107	006B	X	X	Boiler DHW setpoint	V	Depending on units °C / °F
108	006C	X	X	Boiler operation	-	0..x
109	006D	X	X	DHW type	-	0..x
110	006E	X	X	CH mode	-	0..x
111	006F	X	X	DHW mode	-	0..x
112	0070	X	-	Supply temperature	V	Depending on units °C / °F
113	0071	X	-	Return temperature	V	Depending on units °C / °F
114	0072	X	-	DHW temperature	V	Depending on units °C / °F
115	0073	X		Flue gas temperature	V	Depending on units °C / °F
116	0074	X		Heat exchanger temperature	V	Depending on units °C / °F
117	0075	X		Firing Rate	V	0..100%
118	0076	X		Min Firing Rate	V	0..100%
119	0077	X		Flame current	V	0..x uA
120	0078	X		Water pressure	V	Depending on units 0..x bar/psi
121	0079	X		Analog in	V	0..10,0V
122	007A	X		Analog out	V	0..10,0V
123	007B	X		Information: (optionally implemented)		Bit0: On/Off - Flame Signal Bit1: Ok/Nok - Water level Bit2: Ok/Nok - Low gas pressure Bit3: Ok/Nok - High gas pressure Bit4: On/Off - Air pressure Bit5: Ok/Nok - Blocked flue Bit6: On/Off - Air damper Bit7:
124	007C	X		CH pump	V	0/100 or 0..100%
125	007D	X		DHW pump	V	0/100 or 0..100%
126	007E	X		Ignition count OK		0..65536, resolution 16
127	007F	X		Ignition count Failed		0..65536, resolution 1
128	0080	X	-	Flame count Failed	-	0..65536, resolution 1
129	0081	X	-	Burner High hours / CH Hours	-	0..65536 hours

Table 1: AM Managing Boiler Parameters

Holding Register		Access		Parameter Name	Automatic Conversion	Range
		R	W			
130	0082	X	-	Burner Med hours / DHW Hours	-	0..65536 hours
131	0083	X	-	Burner Low hours	-	0..65536 hours
-	..	-	-	Reserved	-	-
150	0096	X	-	Dependent State	-	See state table
151	0097	X	-	Dependent Status	-	See status table
152	0096	X	-	Dependent Error Number	-	See error list
153	0096	X	-	Dependent Firing Rate	V	0..100%
-	-	-	-	Reserved	-	-
199	00C7	-	-	Reserved	-	-

Table 2: AM Controller (Managing) Parameters

Holding Register		Access		Parameter Name	Automatic Conversion	Range
		R	W			
200	00C8	X	-	Controller State	-	See controller state table
201	00C9	X	-	Controller Status	-	See controller status table
202	00CA	X	-	Controller Error Code	-	See controller error list
203	00CB	X	-	Controller Warning Code	-	See controller warning list
204	00CC	X	X	Controller CH setpoint	V	Depending on units °C / °F
205	00CD	X	X	Controller DHW setpoint	V	Depending on units °C / °F
206	00CE	X	X	High Outdoor Air temperature	V	Depending on units °C / °F
207	00CF	X	X	Minimum outdoor air setpoint	V	Depending on units °C / °F
208	00D0	X	X	Low outdoor air temperature	V	Depending on units °C / °F
209	00D1	X	X	Maximum Outdoor air setpoint	V	Depending on units °C / °F
210	00D2	X	X	Outdoor air shutdown temperature	V	Depending on units °C / °F
211	00D3	X	X	Night Setback	-	Depending on units °C / °F
212	00D4	X	-	Header temperature	V	Depending on units °C / °F
213	00D5	X	-	Outside temperature	V	Depending on units °C / °F
214	00D6	X	-	Cascade Firing Rate	V	0..100%
215	00D7	X	-	Min Firing Rate	V	0..100%
216	00D8	X	-	System pump	V	0/100 or 0..100%
	..	-	-	reserved	-	-
299	012B	-	-	reserved	-	-

Table 3: AM Dependent Boiler Parameters

Holding Register		Access		Parameter Name	Automatic Conversion	Range
		R	W			
99	0063	X	X	Control Register	-	Bit 0: Write Enable, Bit 14: Controller Reset
100	0064	X	X	Modbus Units	-	Bit0: °C / °F Bit1: bar / psi
101	0065	X	-	Device type	-	2 = Dependent Boiler
102	0066	X	-	State	-	See state table
103	0067	X	-	Status	-	See status table
104	0068	X	-	Error Code	-	See error list
105	0069	X	-	Warning Code	-	See warning list
106	006A	X	X	Boiler CH setpoint	V	Depending on units °C / °F NOTE: Holding Register 106 only valid when holding register 110 = 0 (constant setpoint).

Table 3: AM Dependent Boiler Parameters

Holding Register		Access		Parameter Name	Automatic Conversion	Range
		R	W			
107	006B	X	X	Boiler DHW setpoint	V	Depending on units °C / °F
108	006C	X	X	Boiler operation	-	0..x
109	006D	X	X	DHW type	-	0..x
110	006E	X	X	CH mode	-	0..x
111	006F	X	X	DHW mode	-	0..x
112	0070	X	-	Supply temperature	V	Depending on units °C / °F
113	0071	X	-	Return temperature	V	Depending on units °C / °F
114	0072	X	-	DHW temperature	V	Depending on units °C / °F
115	0073	X	-	Flue gas temperature	V	Depending on units °C / °F
116	0074	X	-	Heat exchanger temp	V	Depending on units °C / °F
117	0075	X	-	Firing Rate	V	0..100%
118	0076	X	-	Min Firing Rate		0..100%
119	0077	X	-	Flame current	V	0..x uA
120	0078	X	-	Water pressure	V	Depending on units 0..x bar/psi
121	0079	X	-	Analog in	V	0..10,0V
122	007A	X	-	Analog out	V	0..10,0V
123	007B	X	-	Information: (optionally implemented)	-	Bit0: On/Off - Flame Signal Bit1: Ok/Nok - Water level Bit2: Ok/Nok - Low gas pressure Bit3: Ok/Nok - High gas pressure Bit4: On/Off - Air pressure Bit5: Ok/Nok - Blocked flue Bit6: On/Off - Air damper Bit7:
124	007C	X	-	CH pump	V	0/100 or 0..100%
125	007D	X	-	DHW pump	V	0/100 or 0..100%
126	007E	X	-	Ignition count OK	-	0..65536, resolution 16
127	007F	X	-	Ignition count Failed	-	0..65536, resolution 1
128	0080	X	-	Flame count Failed	-	0..65536, resolution 1
129	0081	X	-	Burner High hours / CH hours	-	0..65536 hours
130	0082	X	-	Burner Med hours / DHW hours	-	0..65536 hours
131	0083	X	-	Burner Low hours	-	0..65536 hours
199	00C7	-	-	reserved	-	-

NOTES:

1. Writing to a “write-able” point of an AM Series boiler or heater is a two-step process. First the “Control Register” must be written with a 1 (bit 0 = 1), then the desired register can be written.
2. A controller may also be reset after a lock out error by setting bit 14 of the Control Register.
3. When no Modbus communication (reading or writing) is sensed for more than 4.0 seconds, the Control Register bits will be reset. The bits will also be reset when undefined bits (i.e. other than bits 0 and 14) are set.

CAUTION: Writing of parameters (registers) with a different value is limited to 10,000 times. All (CH, DHW) setpoints and parameters are for preset only. They can be changed with an average of two changes per day, but are NOT to be used for dynamic temperature control.

11.2.AERCO Equipment Point Mappings

11.2.1. AM Mngr Modbus RTU Mappings to BACnet MS/TP, BACnet IP, Metasys N2, Modbus TCP/IP and LonWorks

Single Node Option: The ProtoAir will be discovered as one device and each boiler will show a different range of AV addresses, depending on their Unit or “Comm” Address. A boiler with unit address =1 will have its points starting at AV:1001; Boiler address 2 will begin at AV:2001; Boiler with unit address 3 starts at AV:3001, and so on.

AM Mngr Modbus RTU Mappings to BACnet MS/TP, BACnet IP, Metasys N2, Modbus TCP/IP and LonWorks							
Name / Point Name	BACnet Object Type	BACnet Object ID	N2 Data Type	N2 Point Address	Lon Name	Lon SNVT	Modbus Address
Modbus Units	AV	1	AO	1	nvi/nvoModUnits_XXX	SNVT_count_f	40101
Device Type	AI	2	AI	2	nvoDevType_XXX	SNVT_count_f	40102
State	AI	3	AI	3	nvoState_XXX	SNVT_count_f	40103
Status	AI	4	AI	4	nvoStatus_XXX	SNVT_count_f	40104
Error Code	AI	5	AI	5	nvoErrCode_XXX	SNVT_count_f	40105
Warning Code	AI	6	AI	6	nvoWarnCode_XXX	SNVT_count_f	40106
Boiler CH SP	AV	7	AO	7	nvi/nvoBlrCHSP_XXX	SNVT_count_f	40107
Boiler DHW SP	AV	8	AO	8	nvi/nvoBlrDHWSP_XXX	SNVT_count_f	40108
Boiler Operation	AV	9	AO	9	nvi/nvoBlrOp_XXX	SNVT_count_f	40109
DHW Type	AV	10	AO	10	nvi/nvoDHWType_XXX	SNVT_count_f	40110
CH Mode	AV	11	AO	11	nvi/nvoCHMode_XXX	SNVT_count_f	40111
DHW Mode	AV	12	AO	12	nvi/nvoDHWMode_XXX	SNVT_count_f	40112
Supply Temp	AI	13	AI	13	nvoSupTmp_XXX	SNVT_count_f	40113
Return Temp	AI	14	AI	14	nvoRetTmp_XXX	SNVT_count_f	40114
DHW Temp	AI	15	AI	15	nvoDHWTmp_XXX	SNVT_count_f	40115
Flue Gas Temp	AI	16	AI	16	nvoFluGasTmp_XXX	SNVT_count_f	40116
Heat Exchanger Temp	AI	17	AI	17	nvoHtExcTmp_XXX	SNVT_count_f	40117
Firing Rate	AI	18	AI	18	nvoFirRate_XXX	SNVT_lev_percent	40118
Min Firing Rate	AI	19	AI	19	nvoMinFirRat_XXX	SNVT_lev_percent	40119
Flame Current	AI	20	AI	20	nvoFlmCrnt_XXX	SNVT_count_f	40120
Water Pressure	AI	21	AI	21	nvoWtrPrs_XXX	SNVT_count_f	40121
Analog in	AI	22	AI	22	nvoAnalogin_XXX	SNVT_count_f	40122
Analog out	AI	23	AI	23	nvoAnalogout_XXX	SNVT_count_f	40123
Information	AI	24	AI	24	nvoInfo_XXX	SNVT_count_f	40124
CH pump	AI	25	AI	25	nvoCHpump_XXX	SNVT_count_f	40125
DHW pump	AI	26	AI	26	nvoDHWpump_XXX	SNVT_count_f	40126
Ignition Count OK	AI	27	AI	27	nvolgnCntOK_XXX	SNVT_count_f	40127
Ignition Count Failed	AI	28	AI	28	nvolgnCntFI_XXX	SNVT_count_f	40128
Flame Count Failed	AI	29	AI	29	nvoFlmCntFI_XXX	SNVT_count_f	40129
Burner High Hours / CH Hours	AI	30	AI	30	nvoBrnHiHrs_XXX	SNVT_time_hour	40130

AM Mngr Modbus RTU Mappings to BACnet MS/TP, BACnet IP, Metasys N2, Modbus TCP/IP and LonWorks							
Name / Point Name	BACnet Object Type	BACnet Object ID	N2 Data Type	N2 Point Address	Lon Name	Lon SNVT	Modbus Address
Burner Med Hours / DHW Hours	AI	31	AI	31	nvoBrnMedHrs_XXX	SNVT_time_hour	40131
Burner Low Hours	AI	32	AI	32	nvoBrnLoHrs_XXX	SNVT_time_hour	40132
1st Lockout in History	AI	33	AI	33	nvo1LkotHst_XXX	SNVT_count_f	40133
Time after 1st Lockout	AI	34	AI	34	nvoTime1Lkot_XXX	SNVT_time_hour	40134
2nd Lockout	AI	35	AI	35	nvo2LkotHst_XXX	SNVT_count_f	40135
Time after 2nd Lockout	AI	36	AI	36	nvoTime2Lkot_XXX	SNVT_time_hour	40136
3rd Lockout	AI	37	AI	37	nvo3LkotHst_XXX	SNVT_count_f	40137
Time after 3rd Lockout	AI	38	AI	38	nvoTime3kot_XXX	SNVT_time_hour	40138
4th Lockout	AI	39	AI	39	nvo4Lkot_XXX	SNVT_count_f	40139
Time after 4th Lockout	AI	40	AI	40	nvoTime4Lkot_XXX	SNVT_time_hour	40140
1st Blocking Error in History	AI	41	AI	41	nvo1BlkErHst_XXX	SNVT_count_f	40143
Time after 1st Blocking Error	AI	42	AI	42	nvoTime1Blk_XXX	SNVT_time_hour	40144
2nd Blocking Error	AI	43	AI	43	nvo2BlkErHst_XXX	SNVT_count_f	40145
Time after 2nd Blocking Error	AI	44	AI	44	nvoTime2Blk_XXX	SNVT_time_hour	40146
3rd Blocking Error	AI	45	AI	45	nvo3BlkErHst_XXX	SNVT_count_f	40147
Time after 3rd Blocking Error	AI	46	AI	46	nvoTime3Blk_XXX	SNVT_time_hour	40148
4th Blocking Error	AI	47	AI	47	nvo4BlkErHst_XXX	SNVT_count_f	40149
Time after 4th Blocking Error	AI	48	AI	48	nvoTime4Blk_XXX	SNVT_time_hour	40150
Dependent_1 State	AI	49	AI	49	nvoD1State_XXX	SNVT_count_f	40151
Dependent_1 Status	AI	50	AI	50	nvoD1Status_XXX	SNVT_count_f	40152
Dependent_1 Error Number	AI	51	AI	51	nvoD1ErrNum_XXX	SNVT_count_f	40153
Dependent_1 Firing Rate	AI	52	AI	52	nvoD1FirRat_XXX	SNVT_lev_percent	40154
Dependent_2 State	AI	53	AI	53	nvoD2State_XXX	SNVT_count_f	40156
Dependent_2 Status	AI	54	AI	54	nvoD2Status_XXX	SNVT_count_f	40157

AM Mngr Modbus RTU Mappings to BACnet MS/TP, BACnet IP, Metasys N2, Modbus TCP/IP and LonWorks							
Name / Point Name	BACnet Object Type	BACnet Object ID	N2 Data Type	N2 Point Address	Lon Name	Lon SNVT	Modbus Address
Dependent_2 Error Number	AI	55	AI	55	nvoD2ErrNum_XXX	SNVT_count_f	40158
Dependent_2 Firing Rate	AI	56	AI	56	nvoD2FirRat_XXX	SNVT_lev_percent	40159
Dependent_3 State	AI	57	AI	57	nvoD3State_XXX	SNVT_count_f	40161
Dependent_3 Satus	AI	58	AI	58	nvoD3Satus_XXX	SNVT_count_f	40162
Dependent_3 Error Number	AI	59	AI	59	nvoD3ErrNum_XXX	SNVT_count_f	40163
Dependent_3 Firing Rate	AI	60	AI	60	nvoD3FirRat_XXX	SNVT_lev_percent	40164
Dependent_4 State	AI	61	AI	61	nvoD4State_XXX	SNVT_count_f	40166
Dependent_4 Status	AI	62	AI	62	nvoD4Status_XXX	SNVT_count_f	40167
Dependent_4 Error Number	AI	63	AI	63	nvoD4ErrNum_XXX	SNVT_count_f	40168
Dependent_4 Firing Rate	AI	64	AI	64	nvoD4FirRat_XXX	SNVT_lev_percent	40169
Dependent_5 State	AI	65	AI	65	nvoD5State_XXX	SNVT_count_f	40171
Dependent_5 Status	AI	66	AI	66	nvoD5Status_XXX	SNVT_count_f	40172
Dependent_5 Error Number	AI	67	AI	67	nvoD5ErrNum_XXX	SNVT_count_f	40173
Dependent_5 Firing Rate	AI	68	AI	68	nvoD5FirRat_XXX	SNVT_lev_percent	40174
Dependent_6 State	AI	69	AI	69	nvoD6State_XXX	SNVT_count_f	40176
Dependent_6 Status	AI	70	AI	70	nvoD6Status_XXX	SNVT_count_f	40177
Dependent_6 Error Number	AI	71	AI	71	nvoD6ErrNum_XXX	SNVT_count_f	40178
Dependent_6 Firing Rate	AI	72	AI	72	nvoD6FirRat_XXX	SNVT_lev_percent	40179
Dependent_7 State	AI	73	AI	73	nvoD7State_XXX	SNVT_count_f	40181
Dependent_7 Status	AI	74	AI	74	nvoD7Status_XXX	SNVT_count_f	40182
Dependent_7 Error Number	AI	75	AI	75	nvoD7ErrNum_XXX	SNVT_count_f	40183
Dependent_7 Firing Rate	AI	76	AI	76	nvoD7FirRat_XXX	SNVT_lev_percent	40184
Controller State	AI	77	AI	77	nvoCtlState_XXX	SNVT_count_f	40201
Controller Status	AI	78	AI	78	nvoCtlStats_XXX	SNVT_count_f	40202

AM Mngr Modbus RTU Mappings to BACnet MS/TP, BACnet IP, Metasys N2, Modbus TCP/IP and LonWorks							
Name / Point Name	BACnet Object Type	BACnet Object ID	N2 Data Type	N2 Point Address	Lon Name	Lon SNVT	Modbus Address
Controller Error Code	AI	79	AI	79	nvoCtlErrCod_XXX	SNVT_count_f	40203
Controller Warning Code	AI	80	AI	80	nvoCtlWrnCod_XXX	SNVT_count_f	40204
Controller CH SP	AV	81	AO	81	nvi/nvoCtlCHSP_XXX	SNVT_count_f	40205
Controller DHW SP	AV	82	AO	82	nvi/nvoCtlDHWSP_XXX	SNVT_count_f	40206
High Outdoor Air Temp	AV	83	AO	83	nvi/nvoHiOATmp_XXX	SNVT_count_f	40207
Minimum Outdoor Air SP	AV	84	AO	84	nvi/nvoMinOASP_XXX	SNVT_count_f	40208
Low Outdoor Air Temp	AV	85	AO	85	nvi/nvoLoOATmp_XXX	SNVT_count_f	40209
Maximum Outdoor Air SP	AV	86	AO	86	nvi/nvoMaxOASP_XXX	SNVT_count_f	40210
Outdoor Air Shutdown Temp	AV	87	AO	87	nvi/nvoOAShdnTmp_XXX	SNVT_count_f	40211
Night Setback	AV	88	AO	88	nvi/nvoNightStbk_XXX	SNVT_count_f	40212
Header Temp	AI	89	AI	89	nvoHeaderTmp_XXX	SNVT_count_f	40213
Outside Temp	AI	90	AI	90	nvoOutsidTmp_XXX	SNVT_count_f	40214
Cascade Firing Rate	AI	91	AI	91	nvoCscFirRat_XXX	SNVT_lev_percent	40215
Min Firing Rate	AI	92	AI	92	nvoMinFirR2_XXX	SNVT_lev_percent	40216
System Pump	AI	93	AI	93	nvoSysTmpump_XXX	SNVT_count_f	40217
Amount of Dep Detected	AI	94	AI	94	nvoDepDetect_XXX	SNVT_count_f	40218
Control Register	MV	95	AO	95	nviCtlWord_XXX	SNVT_count_f	40100

11.2.2. AM Dep Modbus RTU Mappings to BACnet MS/TP, BACnet IP, Metasys N2, Modbus TCP/IP and LonWorks

AM Dep Modbus RTU Mappings to BACnet MS/TP, BACnet IP, Metasys N2, Modbus TCP/IP and LonWorks							
Name / Point Name	BACnet Object Type	BACnet Object ID	N2 Data Type	N2 Point Address	Lon Name	Lon SNVT	Modbus Address
Modbus Units	AV	1	AO	1	nvi/nvoModUnits_XXX	SNVT_count_f	40101
Device Type	AI	2	AI	2	nvoDevType_XXX	SNVT_count_f	40102
State	AI	3	AI	3	nvoState_XXX	SNVT_count_f	40103
Status	AI	4	AI	4	nvoStatus_XXX	SNVT_count_f	40104
Error Code	AI	5	AI	5	nvoErrCode_XXX	SNVT_count_f	40105
Warning Code	AI	6	AI	6	nvoWarnCode_XXX	SNVT_count_f	40106
Boiler CH SP	AV	7	AO	7	nvi/nvoBlrCHSP_XXX	SNVT_count_f	40107
Boiler DHW SP	AV	8	AO	8	nvi/nvoBlrDHWSP_XXX	SNVT_count_f	40108
Boiler Operation	AV	9	AO	9	nvi/nvoBlrOp_XXX	SNVT_count_f	40109
DHW Type	AV	10	AO	10	nvi/nvoDHWType_XXX	SNVT_count_f	40110
CH Mode	AV	11	AO	11	nvi/nvoCHMode_XXX	SNVT_count_f	40111
DHW Mode	AV	12	AO	12	nvi/nvoDHWMode_XX X	SNVT_count_f	40112
Supply Temp	AI	13	AI	13	nvoSupTmp_XXX	SNVT_count_f	40113
Return Temp	AI	14	AI	14	nvoRetTmp_XXX	SNVT_count_f	40114
DHW Temp	AI	15	AI	15	nvoDHWTmp_XXX	SNVT_count_f	40115
Flue Gas Temp	AI	16	AI	16	nvoFluGasTmp_XXX	SNVT_count_f	40116
Heat Exchanger Temp	AI	17	AI	17	nvoHtExcTmp_XXX	SNVT_count_f	40117
Firing Rate	AI	18	AI	18	nvoFirRate_XXX	SNVT_lev_percent	40118
Min Firing Rate	AI	19	AI	19	nvoMinFirRat_XXX	SNVT_lev_percent	40119
Flame Current	AI	20	AI	20	nvoFlmCrnt_XXX	SNVT_count_f	40120
Water Pressure	AI	21	AI	21	nvoWtrPrs_XXX	SNVT_count_f	40121
Analog in	AI	22	AI	22	nvoAnalogin_XXX	SNVT_count_f	40122
Analog out	AI	23	AI	23	nvoAnalogout_XXX	SNVT_count_f	40123
Information	AI	24	AI	24	nvoInfo_XXX	SNVT_count_f	40124
CH pump	AI	25	AI	25	nvoCHpump_XXX	SNVT_count_f	40125
DHW pump	AI	26	AI	26	nvoDHWpump_XXX	SNVT_count_f	40126
Ignition Count OK	AI	27	AI	27	nvolgnCntOK_XXX	SNVT_count_f	40127
Ignition Count Failed	AI	28	AI	28	nvolgnCntFI_XXX	SNVT_count_f	40128

AM Dep Modbus RTU Mappings to BACnet MS/TP, BACnet IP, Metasys N2, Modbus TCP/IP and LonWorks							
Name / Point Name	BACnet Object Type	BACnet Object ID	N2 Data Type	N2 Point Address	Lon Name	Lon SNVT	Modbus Address
Flame Count Failed	AI	29	AI	29	nvoFlmCntFl_XXX	SNVT_count_f	40129
Burner High Hours / CH Hours	AI	30	AI	30	nvoBrnHiHrs_XXX	SNVT_time_hour	40130
Burner Med Hours / DHW Hours	AI	31	AI	31	nvoBrnMedHrs_XXX	SNVT_time_hour	40131
Burner Low Hours	AI	32	AI	32	nvoBrnLoHrs_XXX	SNVT_time_hour	40132
1st Lockout in History	AI	33	AI	33	nvo1LkotHst_XXX	SNVT_count_f	40133
Time after 1st Lockout	AI	34	AI	34	nvoTime1Lkot_XXX	SNVT_time_hour	40134
2nd Lockout	AI	35	AI	35	nvo2LkotHst_XXX	SNVT_count_f	40135
Time after 2nd Lockout	AI	36	AI	36	nvoTime2Lkot_XXX	SNVT_time_hour	40136
3rd Lockout	AI	37	AI	37	nvo3LkotHst_XXX	SNVT_count_f	40137
Time after 3rd Lockout	AI	38	AI	38	nvoTime3kot_XXX	SNVT_time_hour	40138
4th Lockout	AI	39	AI	39	nvo4Lkot_XXX	SNVT_count_f	40139
Time after 4th Lockout	AI	40	AI	40	nvoTime4Lkot_XXX	SNVT_time_hour	40140
1st Blocking Error in History	AI	41	AI	41	nvo1BlkErHst_XXX	SNVT_count_f	40143
Time after 1st Blocking Error	AI	42	AI	42	nvoTime1Blk_XXX	SNVT_time_hour	40144
2nd Blocking Error	AI	43	AI	43	nvo2BlkErHst_XXX	SNVT_count_f	40145
Time after 2nd Blocking Error	AI	44	AI	44	nvoTime2Blk_XXX	SNVT_time_hour	40146
3rd Blocking Error	AI	45	AI	45	nvo3BlkErHst_XXX	SNVT_count_f	40147
Time after 3rd Blocking Error	AI	46	AI	46	nvoTime3Blk_XXX	SNVT_time_hour	40148
4th Blocking Error	AI	47	AI	47	nvo4BlkErHst_XXX	SNVT_count_f	40149
Time after 4th Blocking Error	AI	48	AI	48	nvoTime4Blk_XXX	SNVT_time_hour	40150
Control Register	MV	95	AO	95	nviCtlWord_XXX	SNVT_count_f	40100

11.2.3. C-More Modbus RTU Mappings to BACnet MS/TP, BACnet IP, Metasys N2, Modbus TCP/IP and LonWorks

Name	Point Name	BACnet Object Type	BACnet Object ID	N2 Data Type	N2 Point Address	Lon Name	Lon SNVT	Modbus Address
Fire Rate Out	boilerstate_XXX	AV	1	ADF	1	nvoBlrState_XXX	SNVT_count_inc	30009
Active Setpoint	effectsetpt_XXX	AV	2	ADF	2	nvoEffSetpt_XXX	SNVT_count_inc	30017
Net Remote Setpoint	setpt_XXX	AV	3	ADF	3	nviSetpt_XXX	SNVT_count_inc	40001
Net Direct Drive	boilercmd_XXX	AV	4	ADF	4	nviBlrCmd_XXX	SNVT_count_inc	40002
Fire Rate In	boilerload_XXX	AV	5	ADF	5	nvoBlrLoad_XXX	SNVT_count_inc	30018
Outlet Temp	localsuptemp_XXX	AV	6	ADF	6	nvoLocSupTmp_XX X	SNVT_count_inc	30003
Display Code	dispcode_XXX	AV	7	ADF	7	nvoDispCode_XXX	SNVT_count_inc	30001
Unit Status	unitstat_XX	AV	8	ADF	8	nvoUnitStat_XXX	SNVT_count_inc	30002
Run Cycles	runcycles_XXX	AV	9	ADF	9	nvoRunCycles_XX X	SNVT_count_f	30012, 30013
Run Hours	runhours_XXX	AV	10	ADF	10	nvoRunHours_XXX	SNVT_count_f	30014, 30015
Oxygen Level	o2level_XX X	AV	11	ADF	11	nvoO2Lev_XXX	SNVT_count_inc	30010
Exhaust Temp	exhtemp_XXX	AV	12	ADF	12	nvoLocExhTmp_XX X	SNVT_count_inc	30007

11.2.4. Modulex Modbus RTU Mappings to BACnet MS/TP, BACnet IP, Metasys N2, Modbus TCP/IP and LonWorks

Name	Point Name	BACnet Object Type	BACnet Object ID	N2 Data Type	N2 Point Address	Lon Name	Lon SNVT	Modbus Address
Actual Modulation Level	boilerstate_XXX	AV	1	ADF	1	nvoMlxState_XX	SNVT_count_inc	41009
Target Setpoint	effectsetpt_XXX	AV	2	ADF	2	nvoMlxSetpt_XX	SNVT_count_inc	41019
Requested Outlet Temp	setpt_XXX	AV	3	ADF	3	nviMlxSPRq_XX	SNVT_count_inc	41005
Net Direct Drive	boilercmd_XXX	AV	4	ADF	4	nviMlxCmd_XX	SNVT_count_inc	40002
Modulation Level In	boilerload_XXX	AV	5	ADF	5	nvoMlxLoad_XX	SNVT_count_inc	41201
Flow Sensor Temp	localsuptemp_XXX	AV	6	ADF	6	nvoMlxSupTm p_XXX	SNVT_count_inc	41003
Display Code	dispcode_XX	AV	7	ADF	7	nvoMlxDispCd_XXX	SNVT_count_inc	30001
Error Code	errcode_XX	AV	8	ADF	8	nvoMlxErrCod_XXX	SNVT_count_f	40001
Unit Status	unitstat_XX	AV	9	ADF	9	nvoMlxStat_XX	SNVT_count_inc	30002
Return Flow Temp	returntemp_XXX	AV	10	ADF	10	nvoMlxRetTmp_XXX	SNVT_count_inc	41004

11.2.5. ECS/SP Modbus RTU Mappings to BACnet MS/TP, BACnet IP, Metasys N2, Modbus TCP/IP and LonWorks

Name	Point Name	BACnet Object Type	BACnet Object ID	N2 Data Type	N2 Point Address	Lon Name	Lon SNVT	Modbus Address
Control Output Signal	boilerstate_XXX	AV	1	ADF	1	nvoEcsState_XXX	SNVT_count_inc	30004
Target Setpoint	effectsetpt_XXX	AV	2	ADF	2	nvoEcsSetpt_XXX	SNVT_count_inc	30006
Remote Setpoint	setpt_XXX	AV	3	ADF	3	nviEcsSPRq_XX	SNVT_count_inc	40027
Outlet Temp	localsuptemp_XXX	AV	4	ADF	4	nvoEcsSupTm_p_XXX	SNVT_count_inc	30002
Fbk Sensor Temp	localrettemp_XXX	AV	5	ADF	5	nvoEcsRetTm_p_XXX	SNVT_count_inc	30290
Over Temp Alarm	unitstat_XX X	AV	6	ADF	6	nvoEcsStat_XX	SNVT_count_inc	30075
Flow Rate/Mixed Temp	flowrate_XX XX	AV	7	ADF	7	nvoEcsFlow_XX	SNVT_count_inc	30291
Alternate Set Point	Setpt2_XXX	AV	8	ADF	8	nviEcsSPRq2_XXX	SNVT_count_inc	40486

11.2.6. ACS/BMSII/BMS Modbus RTU Mappings to BACnet MS/TP, BACnet IP, Metasys N2, Modbus TCP/IP and LonWorks

Name	Point Name	BACnet Object Type	BACnet Object ID	N2 Data Type	N2 Point Address	Lon Name	Lon SNVT	Modbus Address
Fire Rate Out	boilerstate_XX	AV	1	ADF	1	nvoBlrState_XXX	SNVT_count_inc	30005
Header Set Temp	effectsetpt_XX	AV	2	ADF	2	nvoEffSetpt_XXX	SNVT_count_inc	30006
Net Header Set Temp	setpt_XXX	AV	3	ADF	3	nviSetpt_XXX	SNVT_count_inc	40005
Header Temp	localsuptemp_XXX	AV	4	ADF	4	nvoLocSupTm_p_XXX	SNVT_count_inc	30002
Outside Air Temp	localoatemp_XXX	AV	5	ADF	5	nvoLocOATm_p_XXX	SNVT_count_inc	30003
Display Code	dispcode_XXX	AV	6	ADF	6	nvoDispCode_XXX	SNVT_count_inc	30011
Number Boilers Fired	blrfired_XXX	AV	7	ADF	7	nvoBlrsFired_XXX	SNVT_count_inc	30008
Number Boilers Online	blronline_XXX	AV	8	ADF	8	nvoBlrOnline_XXX	SNVT_count_inc	30009
Last Boiler Fired	blrlast_XXX	AV	9	ADF	9	nvoLastFired_XXX	SNVT_count_inc	30017

Name	Point Name	BACnet Object Type	BACnet Object ID	N2 Data Type	N2 Point Address	Lon Name	Lon SNVT	Modbus Address
Boiler 1 Status	blr1stat_XXX	AV	10	ADF	10	nvoBlr1Stat_XXX	SNVT_count_inc	30018
Boiler 2 Status	blr2stat_XXX	AV	11	ADF	11	nvoBlr2Stat_XXX	SNVT_count_inc	30019
Boiler 3 Status	blr3stat_XXX	AV	12	ADF	12	nvoBlr3Stat_XXX	SNVT_count_inc	30020
Boiler 4 Status	blr4stat_XXX	AV	13	ADF	13	nvoBlr4Stat_XXX	SNVT_count_inc	30021
Boiler 5 Status	blr5stat_XXX	AV	14	ADF	14	nvoBlr5Stat_XXX	SNVT_count_inc	30022
Boiler 6 Status	blr6stat_XXX	AV	15	ADF	15	nvoBlr6Stat_XXX	SNVT_count_inc	30023
Boiler 7 Status	blr7stat_XXX	AV	16	ADF	16	nvoBlr7Stat_XXX	SNVT_count_inc	30024
Boiler 8 Status	blr8stat_XXX	AV	17	ADF	17	nvoBlr8Stat_XXX	SNVT_count_inc	30025
Net Boiler 1 Status	netblr1stat_XX	AV	18	ADF	18	nvoNetBlr1Stat_XXX	SNVT_count_inc	30026
Net Boiler 2 Status	netblr2stat_XX	AV	19	ADF	19	nvoNetBlr2Stat_XXX	SNVT_count_inc	30027
Net Boiler 3 Status	netblr3stat_XX	AV	20	ADF	20	nvoNetBlr3Stat_XXX	SNVT_count_inc	30028
Net Boiler 4 Status	netblr4stat_XX	AV	21	ADF	21	nvoNetBlr4Stat_XXX	SNVT_count_inc	30029
Net Boiler 5 Status	netblr5stat_XX	AV	22	ADF	22	nvoNetBlr5Stat_XXX	SNVT_count_inc	30030
Net Boiler 6 Status	netblr6stat_XX	AV	23	ADF	23	nvoNetBlr6Stat_XXX	SNVT_count_inc	30031
Net Boiler 7 Status	netblr7stat_XX	AV	24	ADF	24	nvoNetBlr7Stat_XXX	SNVT_count_inc	30032
Net Boiler 8 Status	netblr8stat_XX	AV	25	ADF	25	nvoNetBlr8Stat_XXX	SNVT_count_inc	30033
Net Boiler 9 Status	netblr9stat_XX	AV	26	ADF	26	nvoNetBlr9Stat_XXX	SNVT_count_inc	30034
Net Boiler 10 Status	netblr10stat_XXX	AV	27	ADF	27	nvoNetBlr10Stat_XXX	SNVT_count_inc	30035
Net Boiler 11 Status	netblr11stat_XXX	AV	28	ADF	28	nvoNetBlr11Stat_XXX	SNVT_count_inc	30036
Net Boiler 12 Status	netblr12stat_XXX	AV	29	ADF	29	nvoNetBlr12Stat_XXX	SNVT_count_inc	30037
Net Boiler 13 Status	netblr13stat_XXX	AV	30	ADF	30	nvoNetBlr13Stat_XXX	SNVT_count_inc	30038
Net Boiler 14 Status	netblr14stat_XXX	AV	31	ADF	31	nvoNetBlr14Stat_XXX	SNVT_count_inc	30039
Net Boiler 15 Status	netblr15stat_XXX	AV	32	ADF	32	nvoNetBlr15Stat_XXX	SNVT_count_inc	30040

Name	Point Name	BACnet Object Type	BACnet Object ID	N2 Data Type	N2 Point Address	Lon Name	Lon SNVT	Modbus Address
Net Boiler 16 Status	netblr16stat_XXX	AV	33	ADF	33	nvoNetBlr16 Stat_XXX	SNVT_count_inc	30041
Net Boiler 17 Status	netblr17stat_XXX	AV	34	ADF	34	nvoNetBlr17 Stat_XXX	SNVT_count_inc	30042
Net Boiler 18 Status	netblr18stat_XXX	AV	35	ADF	35	nvoNetBlr18 Stat_XXX	SNVT_count_inc	30043
Net Boiler 19 Status	netblr19stat_XXX	AV	36	ADF	36	nvoNetBlr19 Stat_XXX	SNVT_count_inc	30044
Net Boiler 20 Status	netblr20stat_XXX	AV	37	ADF	37	nvoNetBlr20 Stat_XXX	SNVT_count_inc	30045
Net Boiler 21 Status	netblr21stat_XXX	AV	38	ADF	38	nvoNetBlr21 Stat_XXX	SNVT_count_inc	30046
Net Boiler 22 Status	netblr22stat_XXX	AV	39	ADF	39	nvoNetBlr22 Stat_XXX	SNVT_count_inc	30047
Net Boiler 23 Status	netblr23stat_XXX	AV	40	ADF	40	nvoNetBlr23 Stat_XXX	SNVT_count_inc	30048
Net Boiler 24 Status	netblr24stat_XXX	AV	41	ADF	41	nvoNetBlr24 Stat_XXX	SNVT_count_inc	30049
Net Boiler 25 Status	netblr25stat_XXX	AV	42	ADF	42	nvoNetBlr25 Stat_XXX	SNVT_count_inc	30050
Net Boiler 26 Status	netblr26stat_XXX	AV	43	ADF	43	nvoNetBlr26 Stat_XXX	SNVT_count_inc	30051
Net Boiler 27 Status	netblr27stat_XXX	AV	44	ADF	44	nvoNetBlr27 Stat_XXX	SNVT_count_inc	30052
Net Boiler 28 Status	netblr28stat_XXX	AV	45	ADF	45	nvoNetBlr28 Stat_XXX	SNVT_count_inc	30053
Net Boiler 29 Status	netblr29stat_XXX	AV	46	ADF	46	nvoNetBlr29 Stat_XXX	SNVT_count_inc	30054
Net Boiler 30 Status	netblr30stat_XXX	AV	47	ADF	47	nvoNetBlr30 Stat_XXX	SNVT_count_inc	30055
Net Boiler 31 Status	netblr31stat_XXX	AV	48	ADF	48	nvoNetBlr31 Stat_XXX	SNVT_count_inc	30056
Net Boiler 32 Status	netblr32stat_XXX	AV	49	ADF	49	nvoNetBlr32 Stat_XXX	SNVT_count_inc	30057
Return Temp	localrettemp_XXX	AV	50	ADF	50	nvoLocRetT mp_XXX	SNVT_count_inc	30059
Input/Output Status	lostat_XXX	AV	51	ADF	51	nvoIOStat_X XX	SNVT_count_inc	30058

11.2.7. MFC LMV5 Points

Point Name	FPC-N34				FPC-N35		Modbus Address
	BACnet Data Type	BACnet Object Id	N2 Data Type	N2 Point Address	Lon Name	Lon SNVT Type	
Phase	AI	1	AI	1	nvoPhase_XXX	SNVT_count_inc_f	40001
Pos of curr act fuel act	AI	2	AI	2	nvoPosCrAcFl_XXX	SNVT_count_inc_f	40002
Pos of gas actuator	AI	3	AI	3	nvoPosGasAct_XXX	SNVT_count_inc_f	40003
Pos of oil actuator	AI	4	AI	4	nvoPosOilAct_XXX	SNVT_count_inc_f	40004
Pos of air actuator	AI	5	AI	5	nvoPosAirAct_XXX	SNVT_count_inc_f	40005
Pos of aux actuator 1	AI	6	AI	6	nvoPosAuxAc1_XXX	SNVT_count_inc_f	40006
Pos of aux actuator 2	AI	7	AI	7	nvoPosAuxAc2_XXX	SNVT_count_inc_f	40007
Pos of aux actuator 3	AI	8	AI	8	nvoPosAuxAc3_XXX	SNVT_count_inc_f	40008
Manipulated variable for VSD	AI	9	AI	9	nvoManVarVSD_XXX	SNVT_lev_percent	40009
Current type of fuel	AI	10	AI	10	nvoCurTypFl_XXX	SNVT_count_inc_f	40010
Current output	AI	11	AI	11	nvoCurOutput_XXX	SNVT_lev_percent	40011
Current setpoint/temp/press	AI	12	AI	12	nvoCurSP_Tmp_XXX	SNVT_count_inc_f	40012
Actual value/temp/press	AI	13	AI	13	nvoActVal_Tp_XXX	SNVT_count_inc_f	40013
Flame signal	AI	14	AI	14	nvoFlameSig_XXX	SNVT_lev_percent	40014
Current fuel throughput	AI	15	AI	15	nvoCurFlThr_XXX	SNVT_count_inc_f	40015
Current O2 value	AI	16	AI	16	nvoCurO2Val_XXX	SNVT_lev_percent	40016
Volume unit of gas	AI	17	AI	17	nvoVolGsUnit_XXX	SNVT_count_inc_f	40017
Volume unit of oil	AI	18	AI	18	nvoVolOIUnit_XXX	SNVT_count_inc_f	40018
Unit of temp	AI	19	AI	19	nvoUnitTemp_XXX	SNVT_count_inc_f	40019
Unit of press	AI	20	AI	20	nvoUnitPress_XXX	SNVT_count_inc_f	40020
Sensor selection	AI	21	AI	21	nvoSensorSel_XXX	SNVT_count_inc_f	40021
Startup counter total	AI	22	AI	22	nvoStrtCnToT_XXX	SNVT_count_inc_f	40022, 40022
Hours run counter	AI	23	AI	23	nvoHrsRunCnt_XXX	SNVT_count_inc_f	40024, 40025
Current error: Error code	AI	24	AI	24	nvoErrCode_XXX	SNVT_count_inc_f	40026
Current error: Diag code	AI	25	AI	25	nvoDiagCode_XXX	SNVT_count_inc_f	40027
Current error: Error class	AI	26	AI	26	nvoErrClass_XXX	SNVT_count_inc_f	40028
Current error: Error phase	AI	27	AI	27	nvoErrPhase_XXX	SNVT_count_inc_f	40029
Temp limiter OFF threshold	AI	28	AI	28	nvoTmpLmOfTh_XXX	SNVT_count_inc_f	40030
Supply air temp	AI	29	AI	29	nvoSupAirTmp_XXX	SNVT_count_inc_f	40031
Flue gas temp	AI	30	AI	30	nvoFluGasTmp_XXX	SNVT_count_inc_f	40032
Combustion efficiency	AI	31	AI	31	nvoComEff_XXX	SNVT_lev_percent	40033
Inputs	AI	32	AI	32	nvoInputs_XXX	SNVT_count_inc_f	40036
Outputs	AI	33	AI	33	nvoOutputs_XXX	SNVT_count_inc_f	40038
Program stop	AV	34	AO	34	nvi/nvoProgStop_XXX	SNVT_count_inc_f	40039

Point Name	FPC-N34				FPC-N35		Modbus Address
	BACnet Data Type	BACnet Object Id	N2 Data Type	N2 Point Address	Lon Name	Lon SNVT Type	
Op mode with load Ctrller	AV	35	AO	35	nvi/nvoOpModeLoc_XXX	SNVT_count_inc_f	40040
Selection of man or auto oper	AI	36	AI	36	nvoSel_Mn_At_XXX	SNVT_count_inc_f	40041
Modbus mode: Local/Remote	AV	37	AO	37	nvi/nvoModMdLcRm_XXX	SNVT_count_inc_f	40042
Modbus downtime	AV	38	AO	38	nvi/nvoModDwnTm_XXX	SNVT_time_sec	40043
Operating mode in Remote mode	AV	39	AO	39	nvi/nvoOpModeRem_XXX	SNVT_count_inc_f	40044
External setpoint W3 Unit	AV	40	AO	40	nvi/nvoExtSPW3Un_XXX	SNVT_count_inc_f	40045
Predefined output mod./multistage	AV	41	AO	41	nvi/nvoPreOutMod_XXX	SNVT_count_inc_f	40046
Fuel selection AZL	AV	42	AO	42	nvi/nvoFISelAZL_XXX	SNVT_count_inc_f	40047
Setpoint W1	AV	43	AO	43	nvi/nvoSP_W1_XXX	SNVT_count_inc_f	40048
Setpoint W2	AV	44	AO	44	nvi/nvoSP_W2_XXX	SNVT_count_inc_f	40049
Weekday	AV	45	AO	45	nvi/nvoWeekday_XXX	SNVT_count_inc_f	40050
Date Reg 1	AV	46	AO	46	nvi/nvoDate_R1_XXX	SNVT_count_inc_f	40051
Date Reg 2	AI	47	AI	47	nvoDate_R2_XXX	SNVT_count_inc_f	40052
Date Reg 3	AI	48	AI	48	nvoDate_R3_XXX	SNVT_count_inc_f	40053
Time of day Reg 1	AV	49	AO	49	nvi/nvoTimDay_R1_XXX	SNVT_count_inc_f	40054
Time of day Reg 2	AI	50	AI	50	nvoTimDay_R2_XXX	SNVT_count_inc_f	40055
Time of day Reg 3	AI	51	AI	51	nvoTimDay_R3_XXX	SNVT_count_inc_f	40056
Hours run gas	AV	52	AO	52	nvi/nvoHrsRunGas_XXX	SNVT_time_hour	40057, 40058
Hours run oil stage 1 or modulating	AV	53	AO	53	nvi/nvoHrRnOils1_XXX	SNVT_time_hour	40059, 40060
Hours run oil stage 2 or modulating	AV	54	AO	54	nvi/nvoHrRnOils2_XXX	SNVT_time_hour	40061, 40062
Hours run oil stage 3 or modulating	AV	55	AO	55	nvi/nvoHrRnOils3_XXX	SNVT_time_hour	40063, 40064
Hours run total	AV	56	AO	56	nvi/nvoHrsRnTotW_XXX	SNVT_time_hour	40065, 40066
Hours run total	AI	57	AI	57	nvoHrsRnTot_XXX	SNVT_time_hour	40067, 40068
Hours run device connected to power	AI	58	AI	58	nvoHrRnDvPwr_XXX	SNVT_time_hour	40069, 40070
Startup counter gas	AV	59	AO	59	nvi/nvoStCntGas_XXX	SNVT_count_inc_f	40071, 40072
Startup counter oil	AV	60	AO	60	nvi/nvoStCntOil_XXX	SNVT_count_inc_f	40073, 40074
Startup counter total	AV	61	AO	61	nvi/nvoStCntTotW_XXX	SNVT_count_inc_f	40075, 40076
Startup counter total	AI	62	AI	62	nvoStCntTot_XXX	SNVT_count_inc_f	40077, 40078
Fuel volume gas	AV	63	AO	63	nvi/nvoFuelVIGas_XXX	SNVT_count_inc_f	40079, 40080

Point Name	FPC-N34				FPC-N35		Modbus Address
	BACnet Data Type	BACnet Object Id	N2 Data Type	N2 Point Address	Lon Name	Lon SNVT Type	
Fuel volume oil	AV	64	AO	64	nvi/nvoFuelVIOil_XXX	SNVT_count_inc_f	40081, 40082
Number of lockouts	AI	65	AI	65	nvoNumLockot_XXX	SNVT_count_inc_f	40083
Extra temp sensor	AI	66	AI	66	nvoExtTmpSen_XXX	SNVT_count_inc_f	40084
AZL5 ASN Reg 1	AI	67	AI	67	nvoAZLASN1_XXX	SNVT_count_inc_f	40085
AZL5 ASN Reg 2	AI	68	AI	68	nvoAZLASN2_XXX	SNVT_count_inc_f	40086
AZL5 ASN Reg 3	AI	69	AI	69	nvoAZLASN3_XXX	SNVT_count_inc_f	40087
AZL5 ASN Reg 4	AI	70	AI	70	nvoAZLASN4_XXX	SNVT_count_inc_f	40088
AZL5 ASN Reg 5	AI	71	AI	71	nvoAZLASN5_XXX	SNVT_count_inc_f	40089
AZL5 ASN Reg 6	AI	72	AI	72	nvoAZLASN6_XXX	SNVT_count_inc_f	40090
AZL5 ASN Reg 7	AI	73	AI	73	nvoAZLASN7_XXX	SNVT_count_inc_f	40091
AZL5 ASN Reg 8	AI	74	AI	74	nvoAZLASN8_XXX	SNVT_count_inc_f	40092
AZL5 parameter set code	AI	75	AI	75	nvoAZLPrStCd_XXX	SNVT_count_inc_f	40093
AZL5 parameter set version	AI	76	AI	76	nvoAZLPrStVr_XXX	SNVT_count_inc_f	40094
AZL5 id date Reg 1	AI	77	AI	77	nvoAZLIDDtR1_XXX	SNVT_count_inc_f	40095
AZL5 id date Reg 2	AI	78	AI	78	nvoAZLIDDtR2_XXX	SNVT_count_inc_f	40096
AZL5 id date Reg 3	AI	79	AI	79	nvoAZLIDDtR3_XXX	SNVT_count_inc_f	40097
AZL5 id number	AI	80	AI	80	nvoAZLIDNum_XXX	SNVT_count_inc_f	40098
Brnr Ctrl ASN Reg 1	AI	81	AI	81	nvoBrCtASN1_XXX	SNVT_count_inc_f	40099
Brnr Ctrl ASN Reg 2	AI	82	AI	82	nvoBrCtASN2_XXX	SNVT_count_inc_f	40100
Brnr Ctrl ASN Reg 3	AI	83	AI	83	nvoBrCtASN3_XXX	SNVT_count_inc_f	40101
Brnr Ctrl ASN Reg 4	AI	84	AI	84	nvoBrCtASN4_XXX	SNVT_count_inc_f	40102
Brnr Ctrl ASN Reg 5	AI	85	AI	85	nvoBrCtASN5_XXX	SNVT_count_inc_f	40103
Brnr Ctrl ASN Reg 6	AI	86	AI	86	nvoBrCtASN6_XXX	SNVT_count_inc_f	40104
Brnr Ctrl ASN Reg 7	AI	87	AI	87	nvoBrCtASN7_XXX	SNVT_count_inc_f	40105
Brnr Ctrl ASN Reg 8	AI	88	AI	88	nvoBrCtASN8_XXX	SNVT_count_inc_f	40106
Brnr Ctrl parameter set code	AI	89	AI	89	nvoBrnPrStCd_XXX	SNVT_count_inc_f	40107
Brnr Ctrl parameter set version	AI	90	AI	90	nvoBrnPrStVr_XXX	SNVT_count_inc_f	40108
Brnr Ctrl id date Reg 1	AI	91	AI	91	nvoBrnIDDtR1_XXX	SNVT_count_inc_f	40109
Brnr Ctrl id date Reg 2	AI	92	AI	92	nvoBrnIDDtR2_XXX	SNVT_count_inc_f	40110
Brnr Ctrl id date Reg 3	AI	93	AI	93	nvoBrnIDDtR3_XXX	SNVT_count_inc_f	40111
Brnr Ctrl id number	AI	94	AI	94	nvoBrnIDNum_XXX	SNVT_count_inc_f	40112
Software version AZL5	AI	95	AI	95	nvoSw_AZL5_XXX	SNVT_count_inc_f	40113
Software version Brnr Ctrl	AI	96	AI	96	nvoSwBrnCtrl_XXX	SNVT_count_inc_f	40114
Software version load Ctrller	AI	97	AI	97	nvoSwLdCtrl_XXX	SNVT_count_inc_f	40115
Brnr id Reg 1	AI	98	AI	98	nvoBrnr_ID1_XXX	SNVT_count_inc_f	40116
Brnr id Reg 2	AI	99	AI	99	nvoBrnr_ID2_XXX	SNVT_count_inc_f	40117
Brnr id Reg 3	AI	100	AI	100	nvoBrnr_ID3_XXX	SNVT_count_inc_f	40118
Brnr id Reg 4	AI	101	AI	101	nvoBrnr_ID4_XXX	SNVT_count_inc_f	40119
Brnr id Reg 5	AI	102	AI	102	nvoBrnr_ID5_XXX	SNVT_count_inc_f	40120
Brnr id Reg 6	AI	103	AI	103	nvoBrnr_ID6_XXX	SNVT_count_inc_f	40121

Point Name	FPC-N34				FPC-N35		Modbus Address
	BACnet Data Type	BACnet Object Id	N2 Data Type	N2 Point Address	Lon Name	Lon SNVT Type	
Brnr id Reg 7	AI	104	AI	104	nvoBrnr_ID7_XXX	SNVT_count_inc_f	40122
Brnr id Reg 8	AI	105	AI	105	nvoBrnr_ID8_XXX	SNVT_count_inc_f	40123
Min-output gas	AI	106	AI	106	nvoMinOutGas_XXX	SNVT_lev_percent	40124
Max-output gas	AI	107	AI	107	nvoMaxOutGas_XXX	SNVT_lev_percent	40125
Min-output oil	AI	108	AI	108	nvoMinOutOil_XXX	SNVT_lev_percent	40126
Max-output oil	AI	109	AI	109	nvoMaxOutOil_XXX	SNVT_lev_percent	40127
Load limit enduser (modulating)	AV	110	AO	110	nvi/nvoLdLmEndMd_XXX	SNVT_lev_percent	40128
Load limit enduser (multistage)	AV	111	AO	111	nvi/nvoLdLmEndMs_XXX	SNVT_count_inc_f	40129
temp limiter switching differential ON	AI	112	AI	112	nvoTmpLmSwDf_XXX	SNVT_lev_percent	40130
Measuring range temp sensor	AI	113	AI	113	nvoMsrRgTpSn_XXX	SNVT_count_inc_f	40131
Adaption active/inactive	AI	114	AI	114	nvoAdpActv_XXX	SNVT_count_inc_f	40132
Adaption state	AI	115	AI	115	nvoAdpState_XXX	SNVT_count_inc_f	40133
Start adaption	AV	116	AO	116	nvi/nvoStrtAdap_XXX	SNVT_count_inc_f	40134
Adaption output	AV	117	AO	117	nvi/nvoAdapOut_XXX	SNVT_lev_percent	40135
P-value	AV	118	AO	118	nvi/nvoP_Value_XXX	SNVT_lev_percent	40136
I-value	AV	119	AO	119	nvi/nvoI_Value_XXX	SNVT_time_sec	40137
D-value	AV	120	AO	120	nvi/nvoD_Value_XXX	SNVT_time_sec	40138
Current Lockout Error code	AI	121	AI	121	nvoCrLkErCod_XXX	SNVT_count_inc_f	40401
Current Lockout Error diagnostics	AI	122	AI	122	nvoCrLkErDig_XXX	SNVT_count_inc_f	40402
Current Lockout Error class	AI	123	AI	123	nvoCrLkErCls_XXX	SNVT_count_inc_f	40403
Current Lockout Error phase	AI	124	AI	124	nvoCrLkErPhs_XXX	SNVT_count_inc_f	40404
Current Lockout Fuel	AI	125	AI	125	nvoCrLkFuel_XXX	SNVT_count_inc_f	40405
Current Lockout Output	AI	126	AI	126	nvoCrLkOutpt_XXX	SNVT_count_inc_f	40406
Current Lockout Date: Year	AI	127	AI	127	nvoCrLkDtYr_XXX	SNVT_count_inc_f	40407
Current Lockout Date: Month	AI	128	AI	128	nvoCrLkDtMnt_XXX	SNVT_count_inc_f	40408
Current Lockout Date: Day	AI	129	AI	129	nvoCrLkDtDay_XXX	SNVT_count_inc_f	40409
Current Lockout Time of day: Hours	AI	130	AI	130	nvoCrLkTmHrs_XXX	SNVT_count_inc_f	40410
Current Lockout Time of day: Minutes	AI	131	AI	131	nvoCrLkTmMin_XXX	SNVT_count_inc_f	40411
Current Lockout Time of day: Seconds	AI	132	AI	132	nvoCrLkTmSec_XXX	SNVT_count_inc_f	40412
Current Lockout Startup counter total	AI	133	AI	133	nvoCrLkCtTot_XXX	SNVT_count_inc_f	40413

Point Name	FPC-N34				FPC-N35		Modbus Address
	BACnet Data Type	BACnet Object Id	N2 Data Type	N2 Point Address	Lon Name	Lon SNVT Type	
Current Lockout Hours run total	AI	134	AI	134	nvoCrLkHrRnT_XXX	SNVT_time_hour	40415
Current Error Error code	AI	135	AI	135	nvoCrErCode_XXX	SNVT_count_inc_f	40545
Current Error Error diagnostics	AI	136	AI	136	nvoCrErDiag_XXX	SNVT_count_inc_f	40546
Current Error Error class	AI	137	AI	137	nvoCrErClass_XXX	SNVT_count_inc_f	40547
Current Error Error phase	AI	138	AI	138	nvoCrErPhase_XXX	SNVT_count_inc_f	40548
Current Error Fuel	AI	139	AI	139	nvoCrErFuel_XXX	SNVT_count_inc_f	40549
Current Error Output	AI	140	AI	140	nvoCrErOutpt_XXX	SNVT_count_inc_f	40550
Current Error Startup Counter Total	AI	141	AI	141	nvoCrErCtrTo_XXX	SNVT_count_inc_f	40551

11.2.8. MFC RWF55 Points

Point Name	FPC-N34				FPC-N35		Modbus Address
	BACnet Data Type	BACnet Object Id	N2 Data Type	N2 Point Address	Lon Name	Lon SNVT Type	
INPUT 1 X1	AI	1	AI	1	nvoX1_XXX	SNVT_count_inc_f	40001
INPUT 2 X2	AI	2	AI	2	nvoX2_XXX	SNVT_count_inc_f	40003
INPUT 3 X3	AI	3	AI	3	nvoX3_XXX	SNVT_count_inc_f	40005
CURRENT SETPOINT WR	AI	4	AI	4	nvoWR_XXX	SNVT_count_inc_f	40007
FIRST SETPOINT SP1	AV	5	AO	5	nvi/nvoSP1_XXX	SNVT_count_inc_f	40009
SECOND SETPOINT SP2	AV	6	AO	6	nvi/nvoSP2_XXX	SNVT_count_inc_f	40011

Point Name	FPC-N34				FPC-N35		Modbus Address
	BACnet Data Type	BACnet Object Id	N2 Data Type	N2 Point Address	Lon Name	Lon SNVT Type	
REMOTE OPERATING MODE REM	AV	7	AO	7	nvi/nvoRem_XXX	SNVT_count_inc_f	41281
REMOTE MODE OFF ROFF	AV	8	AO	8	nvi/nvoRoff_XXX	SNVT_count_inc_f	41282
REMOTE ON HYSTERESIS RHYS1	AV	9	AO	9	nvi/nvoRHYS1_XXX	SNVT_count_inc_f	41283
REMOTE OFF HYST BOTTOM RHYS2	AV	10	AO	10	nvi/nvoRHYS2_XXX	SNVT_count_inc_f	41285
REMOTE OFF HYST TOP RHYS3	AV	11	AO	11	nvi/nvoRHYS3_XXX	SNVT_count_inc_f	41287
REMOTE SETPOINT SPR	AV	12	AO	12	nvi/nvoSPr_XXX	SNVT_count_inc_f	41289
REMOTE BURNER OUTPUT RK1	AV	13	AO	13	nvi/nvoRk1_XXX	SNVT_count_inc_f	41291
REMOTE K2 OUTPUT RK2	AV	14	AO	14	nvi/nvoRk2_XXX	SNVT_count_inc_f	41292
REMOTE K3 OUTPUT RK3	AV	15	AO	15	nvi/nvoRk3_XXX	SNVT_count_inc_f	41293
REMOTE K6 OUTPUT RK6	AV	16	AO	16	nvi/nvoRk6_XXX	SNVT_count_inc_f	41294
REMOTE STAGE MODE RSTEP	AV	17	AO	17	nvi/nvoRstep_XXX	SNVT_count_inc_f	41295
REMOTE OUTPUT RY	AV	18	AO	18	nvi/nvoRy_XXX	SNVT_count_inc_f	41296
REM ON HYST COOLING RHYS4	AV	19	AO	19	nvi/nvoRHYS4_XXX	SNVT_count_inc_f	41298
REM OFF HYST BTM COOLING RHYS5	AV	20	AO	20	nvi/nvoRHYS5_XXX	SNVT_count_inc_f	41300
REM OFF HYST TOP COOLING RHYS6	AV	21	AO	21	nvi/nvoRHYS6_XXX	SNVT_count_inc_f	41302
INPUT 3 UNFILTERED TEMP	AI	22	AI	22	nvoIn3_UnflTmp_XXX	SNVT_count_inc_f	44150
ACTUAL OUTPUT Y	AI	23	AI	23	nvoActOutY_XXX	SNVT_count_inc_f	44164
BURNER ALARM	AI	24	AI	24	nvoBrnAlm_XXX	SNVT_count_inc_f	44185
RAMP FUNCTION FnCt	AV	25	AO	25	nvi/nvoFnct_XXX	SNVT_count_inc_f	44196
RAMP SLOPE rASL	AV	26	AO	26	nvi/nvoRasl_XXX	SNVT_count_inc_f	44198
TOLERANCE BAND RAMP toLP	AV	27	AO	27	nvi/nvoTolp_XXX	SNVT_count_inc_f	44200
LIMIT VALUE rAL	AV	28	AO	28	nvi/nvoRal_XXX	SNVT_count_inc_f	44202
ALARM RELAY FUNCTION FnAL	AV	29	AO	29	nvi/nvoFnal_XXX	SNVT_count_inc_f	44206
ALARM LIMIT COMPARATOR AL	AV	30	AO	30	nvi/nvoAlmLimCom_XXX	SNVT_count_inc_f	44208
HYSTERESIS LIMIT COMP HYST	AV	31	AO	31	nvi/nvoHyst_XXX	SNVT_count_inc_f	44210
MODBUS WATCHDOG dtt	AV	32	AO	32	nvi/nvoDtt_XXX	SNVT_count_inc_f	44214
FILTER INPUT 1 dF1	AV	33	AO	33	nvi/nvoDf1_XXX	SNVT_count_inc_f	44216

Point Name	FPC-N34				FPC-N35		Modbus Address
	BACnet Data Type	BACnet Object Id	N2 Data Type	N2 Point Address	Lon Name	Lon SNVT Type	
FILTER INPUT 2 dF2	AV	34	AO	34	nvi/nvoDf2_XXX	SNVT_count_inc_f	44218
FILTER INPUT 3 dF3	AV	35	AO	35	nvi/nvoDf3_XXX	SNVT_count_inc_f	44220
ACTUAL VALUE LIMIT LOW oLlO	AI	36	AI	36	nvoOllO_XXX	SNVT_count_inc_f	44222
ACTUAL VALUE LIMIT HIGH oLHi	AI	37	AI	37	nvoOLi_XXX	SNVT_count_inc_f	44224
PROPORTIONAL BAND Pb1	AV	38	AO	38	nvi/nvoPb1_XXX	SNVT_count_inc_f	52289
DERIVATIVE ACTION TIME dt	AV	39	AO	39	nvi/nvoDt_XXX	SNVT_count_inc_f	52293
INTEGRAL ACTION TIME rt	AV	40	AO	40	nvi/nvoRt_XXX	SNVT_count_inc_f	52295
DEAD BAND db	AV	41	AO	41	nvi/nvoDb_XXX	SNVT_count_inc_f	52301
ACTUATOR RUNNING TIME tt	AV	42	AO	42	nvi/nvoTt_XXX	SNVT_count_inc_f	52307
ON HYSTERESIS HYS1	AV	43	AO	43	nvi/nvoHys1_XXX	SNVT_count_inc_f	52311
OFF HYSTERESIS BOTTOM HYS2	AV	44	AO	44	nvi/nvoHys2_XXX	SNVT_count_inc_f	52313
OFF HYSTERESIS TOP HYS3	AV	45	AO	45	nvi/nvoHys3_XXX	SNVT_count_inc_f	52315
ON HYST COOLING HYS4	AV	46	AO	46	nvi/nvoHys4_XXX	SNVT_count_inc_f	52317
OFF HYST BTM COOLING HYS5	AV	47	AO	47	nvi/nvoHys5_XXX	SNVT_count_inc_f	52319
OFF HYST TOP COOLING HYS6	AV	48	AO	48	nvi/nvoHys6_XXX	SNVT_count_inc_f	52321
REACTION THRESHOLD q	AV	49	AO	49	nvi/nvoQ_XXX	SNVT_count_inc_f	52323
OUTSIDE TEMPERATURE 1 At1	AV	50	AO	50	nvi/nvoAt1_XXX	SNVT_count_inc_f	52417
BOILER TEMPERATURE 1 Ht1	AV	51	AO	51	nvi/nvoHt1_XXX	SNVT_count_inc_f	52419
OUTSIDE TEMPERATURE 2 At2	AV	52	AO	52	nvi/nvoAt2_XXX	SNVT_count_inc_f	52421
BOILER TEMPERATURE 2 Ht2	AV	53	AO	53	nvi/nvoHt2_XXX	SNVT_count_inc_f	52423
INPUT 1 SCALE LOW SCL1	AV	54	AO	54	nvi/nvoScl1_XXX	SNVT_count_inc_f	53351
INPUT 1 SCALE HIGH SCH1	AV	55	AO	55	nvi/nvoSch1_XXX	SNVT_count_inc_f	53353
OFFSET INPUT 1 OFF1	AV	56	AO	56	nvi/nvoOff1_XXX	SNVT_count_inc_f	53355
INPUT 2 SCALE LOW SCL2	AV	57	AO	57	nvi/nvoScl2_XXX	SNVT_count_inc_f	53363
INPUT 2 SCALE HIGH SCH2	AV	58	AO	58	nvi/nvoSch2_XXX	SNVT_count_inc_f	53365
OFFSET INPUT 2 OFF2	AV	59	AO	59	nvi/nvoOff2_XXX	SNVT_count_inc_f	53367
OFFSET INPUT 3 OFF3	AV	60	AO	60	nvi/nvoOff3_XXX	SNVT_count_inc_f	53371

Point Name	FPC-N34				FPC-N35		Modbus Address
	BACnet Data Type	BACnet Object Id	N2 Data Type	N2 Point Address	Lon Name	Lon SNVT Type	
SETPOINT LIMIT SCALE LOW SPL	AV	61	AO	61	nvi/nvoSPI_XXX	SNVT_count_inc_f	53447
SETPOINT LIMIT SCALE HIGH SPH	AV	62	AO	62	nvi/nvoSPH_XXX	SNVT_count_inc_f	53449
INPUT 1 FAULT	BI	1	DI	1	nvoln1Flt_XXX	SNVT_switch	40513 bit 12
INPUT 2 FAULT	BI	2	DI	2	nvoln2Flt_XXX	SNVT_switch	40513 bit 13
INPUT 3 FAULT	BI	3	DI	3	nvoln3Flt_XXX	SNVT_switch	40513 bit 14
STAGE MODE	BI	4	DI	4	nvoStgMd_XXX	SNVT_switch	40514 bit 0
MANUAL OPERATION	BI	5	DI	5	nvoManOp_XXX	SNVT_switch	40514 bit 1
BINARY INPUT 1	BI	6	DI	6	nvoBI1_XXX	SNVT_switch	40514 bit 2
BINARY INPUT 2	BI	7	DI	7	nvoBI2_XXX	SNVT_switch	40514 bit 3
STAT ACTIVE	BI	8	DI	8	nvoStatAct_XXX	SNVT_switch	40513 bit 0
UP ACTIVE	BI	9	DI	9	nvoUpAct_XXX	SNVT_switch	40513 bit 1
DOWN ACTIVE	BI	10	DI	10	nvoDownAct_XXX	SNVT_switch	40513 bit 2
K6 ACTIVE	BI	11	DI	11	nvoK6Act_XXX	SNVT_switch	40513 bit 3

11.2.9. Standalone SmartPlate EV Points

Point Name	BACnet Address	Lon Name	Lon SNVT	Modbus Reg Type	Modbus Data Address
DHW Out	AV: 1	nvoSPEVDhwOut_XXX	SNVT_count_inc	Input	1
Setpoint	AV: 2	nviSPEVSetpoint_XXX	SNVT_count_inc	Holding	2
Valve POS	AV: 4	nvoSPEVValvePOS_XXX	SNVT_count_inc	Input	4
DHW Flow	AV: 364	nvoSPEVDhwFlow_XXX	SNVT_count_inc	Input	364
BW Inlet T	AV: 370	nvoSPEVBWInlet_T_XXX	SNVT_count_inc	Input	370
DHW Inlet T	AV: 373	nvoSPEVDhwInlet_T_XXX	SNVT_count_inc	Input	373
DP	AV: 379	nvoSPEVDP_XXX	SNVT_count_inc	Input	379
Alarm 1 Out	AV: 10249	nvoSPEVAlarm1Out_XXX	SNVT_count_f	Input	10249
Alarm 2 Out	AV: 10265	nvoSPEVAlarm2Out_XXX	SNVT_count_f	Input	10265
Alarm 3 Out	AV: 10281	nvoSPEVAlarm3Out_XXX	SNVT_count_f	Input	10281
Alarm 4 Out	AV: 10297	nvoSPEVAlarm4Out_XXX	SNVT_count_f	Input	10297
Alarm 5 Out	AV: 10313	nvoSPEVAlarm5Out_XXX	SNVT_count_f	Input	10313
Alarm 6 Out	AV: 10329	nvoSPEVAlarm6Out_XXX	SNVT_count_f	Input	10329
Alarm 7 Out	AV: 10345	nvoSPEVAlarm7Out_XXX	SNVT_count_f	Input	10345
Alarm 8 Out	AV: 10361	nvoSPEVAlarm8Out_XXX	SNVT_count_f	Input	10361

11.3. Sixteen C-More/Edge Boilers/Heaters and BST/WHM Master

Equip	Point Name	Name	Read Only	BACnet Type:ID	N2 Type	N2 ID	Lon NAME	Lon SNVT	Lon Direction	Modbus Address
Blr Addr 1										
1	Comm Address	SMD_BAS_IP_HTR_01_0]	✓	AV:300	Data Float	46	nvoHTR_01_1	inc count (9)	Output (non-pollled)	30300
1	Unit Status	SMD_BAS_IP_HTR_01_1]	✓	AV:301	Data Float	47	nvoHTR_01_2	inc count (9)	Output (non-pollled)	30301
1	Fault Code	SMD_BAS_IP_HTR_01_2]	✓	AV:302	Data Float	48	nvoHTR_01_3	inc count (9)	Output (non-pollled)	30302
1	Outlet Temp	SMD_BAS_IP_HTR_01_3]	✓	AV:303	Data Float	49	nvoHTR_01_4	inc count (9)	Output (non-pollled)	30303
1	FFWD Temp	SMD_BAS_IP_HTR_01_4]	✓	AV:304	Data Float	50	nvoHTR_01_5	inc count (9)	Output (non-pollled)	30304
1	Inlet Temp	SMD_BAS_IP_HTR_01_5]	✓	AV:305	Data Float	51	nvoHTR_01_6	inc count (9)	Output (non-pollled)	30305
1	Exhaust Temp	SMD_BAS_IP_HTR_01_6]	✓	AV:306	Data Float	52	nvoHTR_01_7	inc count (9)	Output (non-pollled)	30306
1	Air Temp	SMD_BAS_IP_HTR_01_7]	✓	AV:307	Data Float	53	nvoHTR_01_8	inc count (9)	Output (non-pollled)	30307
1	Flame Strength	SMD_BAS_IP_HTR_01_8]	✓	AV:308	Data Float	54	nvoHTR_01_9	inc count (9)	Output (non-pollled)	30308
1	Fire Rate In	SMD_BAS_IP_HTR_01_9]	✓	AV:309	Data Float	55	nvoHTR_01_10	inc count (9)	Output (non-pollled)	30309
1	Fire Rate Out	SMD_BAS_IP_HTR_01_10]	✓	AV:310	Data Float	56	nvoHTR_01_11	inc count (9)	Output (non-pollled)	30310
1	Unit Type	SMD_BAS_IP_HTR_01_11]	✓	AV:311	Data Float	57	nvoHTR_01_12	inc count (9)	Output (non-pollled)	30311
1	Unit Size	SMD_BAS_IP_HTR_01_12]	✓	AV:312	Data Float	58	nvoHTR_01_13	inc count (9)	Output (non-pollled)	30312
1	Value State	SMD_BAS_IP_HTR_01_13]	✓	AV:313	Data Float	59	nvoHTR_01_14	inc count (9)	Output (non-pollled)	30313
1	Net Remote Setpt	SMD_BAS_IP_HTR_01_14]	✓	AV:314	Data Float	60	nvoHTR_01_15	inc count (9)	Output (non-pollled)	30314
1	Run Cycles Upper	SMD_BAS_IP_HTR_01_15]	✓	AV:315	Data Float	61	nvoHTR_01_16	inc count (9)	Output (non-pollled)	30315
1	Run Cycles Lower	SMD_BAS_IP_HTR_01_16]	✓	AV:316	Data Float	62	nvoHTR_01_17	inc count (9)	Output (non-pollled)	30316
1	Run Hours Upper	SMD_BAS_IP_HTR_01_17]	✓	AV:317	Data Float	63	nvoHTR_01_18	inc count (9)	Output (non-pollled)	30317
1	Run Hours Lower	SMD_BAS_IP_HTR_01_18]	✓	AV:318	Data Float	64	nvoHTR_01_19	inc count (9)	Output (non-pollled)	30318
1	Oxygen Level	SMD_BAS_IP_HTR_01_19]	✓	AV:319	Data Float	65	nvoHTR_01_20	inc count (9)	Output (non-pollled)	30319
Blr Addr 2										
2	Comm Address	SMD_BAS_IP_HTR_02_0]	✓	AV:400	Data Float	66	nvoHTR_02_1	inc count (9)	Output (non-pollled)	30400
2	Unit Status	SMD_BAS_IP_HTR_02_1]	✓	AV:401	Data Float	67	nvoHTR_02_2	inc count (9)	Output (non-pollled)	30401
2	Fault Code	SMD_BAS_IP_HTR_02_2]	✓	AV:402	Data Float	68	nvoHTR_02_3	inc count (9)	Output (non-pollled)	30402
2	Outlet Temp	SMD_BAS_IP_HTR_02_3]	✓	AV:403	Data Float	69	nvoHTR_02_4	inc count (9)	Output (non-pollled)	30403
2	FFWD Temp	SMD_BAS_IP_HTR_02_4]	✓	AV:404	Data Float	70	nvoHTR_02_5	inc count (9)	Output (non-pollled)	30404
2	Inlet Temp	SMD_BAS_IP_HTR_02_5]	✓	AV:405	Data Float	71	nvoHTR_02_6	inc count (9)	Output (non-pollled)	30405
2	Exhaust Temp	SMD_BAS_IP_HTR_02_6]	✓	AV:406	Data Float	72	nvoHTR_02_7	inc count (9)	Output (non-pollled)	30406

Equip	Point Name	Name	Read Only	BACnet Type:ID	N2 Type	N2 ID	Lon NAME	Lon SNVT	Lon Direction	Modbus Address
2	Air Temp	SMD_BAS_IP_HTR_02_7	✓	AV:407	Data Float	73	nvoHTR_02_8	inc count (9)	Output (non-pollled)	30407
2	Flame Strength	SMD_BAS_IP_HTR_02_8	✓	AV:408	Data Float	74	nvoHTR_02_9	inc count (9)	Output (non-pollled)	30408
2	Fire Rate In	SMD_BAS_IP_HTR_02_9	✓	AV:409	Data Float	75	nvoHTR_02_10	inc count (9)	Output (non-pollled)	30409
2	Fire Rate Out	SMD_BAS_IP_HTR_02_10	✓	AV:410	Data Float	76	nvoHTR_02_11	inc count (9)	Output (non-pollled)	30410
2	Unit Type	SMD_BAS_IP_HTR_02_11	✓	AV:411	Data Float	77	nvoHTR_02_12	inc count (9)	Output (non-pollled)	30411
2	Unit Size	SMD_BAS_IP_HTR_02_12	✓	AV:412	Data Float	78	nvoHTR_02_13	inc count (9)	Output (non-pollled)	30412
2	Value State	SMD_BAS_IP_HTR_02_13	✓	AV:413	Data Float	79	nvoHTR_02_14	inc count (9)	Output (non-pollled)	30413
2	Net Remote Setpt	SMD_BAS_IP_HTR_02_14	✓	AV:414	Data Float	80	nvoHTR_02_15	inc count (9)	Output (non-pollled)	30414
2	Run Cycles Upper	SMD_BAS_IP_HTR_02_15	✓	AV:415	Data Float	81	nvoHTR_02_16	inc count (9)	Output (non-pollled)	30415
2	Run Cycles Lower	SMD_BAS_IP_HTR_02_16	✓	AV:416	Data Float	82	nvoHTR_02_17	inc count (9)	Output (non-pollled)	30416
2	Run Hours Upper	SMD_BAS_IP_HTR_02_17	✓	AV:417	Data Float	83	nvoHTR_02_18	inc count (9)	Output (non-pollled)	30417
2	Run Hours Lower	SMD_BAS_IP_HTR_02_18	✓	AV:418	Data Float	84	nvoHTR_02_19	inc count (9)	Output (non-pollled)	30418
2	Oxygen Level	SMD_BAS_IP_HTR_02_19	✓	AV:419	Data Float	85	nvoHTR_02_20	inc count (9)	Output (non-pollled)	30419
Blr Addr 3										
3	Comm Address	SMD_BAS_IP_HTR_03_0	✓	AV:500	Data Float	86	nvoHTR_03_1	inc count (9)	Output (non-pollled)	30500
3	Unit Status	SMD_BAS_IP_HTR_03_1	✓	AV:501	Data Float	87	nvoHTR_03_2	inc count (9)	Output (non-pollled)	30501
3	Fault Code	SMD_BAS_IP_HTR_03_2	✓	AV:502	Data Float	88	nvoHTR_03_3	inc count (9)	Output (non-pollled)	30502
3	Outlet Temp	SMD_BAS_IP_HTR_03_3	✓	AV:503	Data Float	89	nvoHTR_03_4	inc count (9)	Output (non-pollled)	30503
3	FFWD Temp	SMD_BAS_IP_HTR_03_4	✓	AV:504	Data Float	90	nvoHTR_03_5	inc count (9)	Output (non-pollled)	30504
3	Inlet Temp	SMD_BAS_IP_HTR_03_5	✓	AV:505	Data Float	91	nvoHTR_03_6	inc count (9)	Output (non-pollled)	30505
3	Exhaust Temp	SMD_BAS_IP_HTR_03_6	✓	AV:506	Data Float	92	nvoHTR_03_7	inc count (9)	Output (non-pollled)	30506
3	Air Temp	SMD_BAS_IP_HTR_03_7	✓	AV:507	Data Float	93	nvoHTR_03_8	inc count (9)	Output (non-pollled)	30507
3	Flame Strength	SMD_BAS_IP_HTR_03_8	✓	AV:508	Data Float	94	nvoHTR_03_9	inc count (9)	Output (non-pollled)	30508
3	Fire Rate In	SMD_BAS_IP_HTR_03_9	✓	AV:509	Data Float	95	nvoHTR_03_10	inc count (9)	Output (non-pollled)	30509
3	Fire Rate Out	SMD_BAS_IP_HTR_03_10	✓	AV:510	Data Float	96	nvoHTR_03_11	inc count (9)	Output (non-pollled)	30510
3	Unit Type	SMD_BAS_IP_HTR_03_11	✓	AV:511	Data Float	97	nvoHTR_03_12	inc count (9)	Output (non-pollled)	30511
3	Unit Size	SMD_BAS_IP_HTR_03_12	✓	AV:512	Data Float	98	nvoHTR_03_13	inc count (9)	Output (non-pollled)	30512
3	Value State	SMD_BAS_IP_HTR_03_13	✓	AV:513	Data Float	99	nvoHTR_03_14	inc count (9)	Output (non-pollled)	30513
3	Net Remote Setpt	SMD_BAS_IP_HTR_03_14	✓	AV:514	Data Float	100	nvoHTR_03_15	inc count (9)	Output (non-pollled)	30514

Equip	Point Name	Name	Read Only	BACnet Type:ID	N2 Type	N2 ID	Lon NAME	Lon SNVT	Lon Direction	Modbus Address
3	Run Cycles Upper	SMD_BAS_IP_HTR_03_15]	✓	AV:515	Data Float	101	nvoHTR_03_16	inc count (9)	Output (non-pollled)	30515
3	Run Cycles Lower	SMD_BAS_IP_HTR_03_16]	✓	AV:516	Data Float	102	nvoHTR_03_17	inc count (9)	Output (non-pollled)	30516
3	Run Hours Upper	SMD_BAS_IP_HTR_03_17]	✓	AV:517	Data Float	103	nvoHTR_03_18	inc count (9)	Output (non-pollled)	30517
3	Run Hours Lower	SMD_BAS_IP_HTR_03_18]	✓	AV:518	Data Float	104	nvoHTR_03_19	inc count (9)	Output (non-pollled)	30518
3	Oxygen Level	SMD_BAS_IP_HTR_03_19]	✓	AV:519	Data Float	105	nvoHTR_03_20	inc count (9)	Output (non-pollled)	30519
Blr Addr 4										
4	Comm Address	SMD_BAS_IP_HTR_04_0]	✓	AV:600	Data Float	106	nvoHTR_04_1	inc count (9)	Output (non-pollled)	30600
4	Unit Status	SMD_BAS_IP_HTR_04_1]	✓	AV:601	Data Float	107	nvoHTR_04_2	inc count (9)	Output (non-pollled)	30601
4	Fault Code	SMD_BAS_IP_HTR_04_2]	✓	AV:602	Data Float	108	nvoHTR_04_3	inc count (9)	Output (non-pollled)	30602
4	Outlet Temp	SMD_BAS_IP_HTR_04_3]	✓	AV:603	Data Float	109	nvoHTR_04_4	inc count (9)	Output (non-pollled)	30603
4	FFWD Temp	SMD_BAS_IP_HTR_04_4]	✓	AV:604	Data Float	110	nvoHTR_04_5	inc count (9)	Output (non-pollled)	30604
4	Inlet Temp	SMD_BAS_IP_HTR_04_5]	✓	AV:605	Data Float	111	nvoHTR_04_6	inc count (9)	Output (non-pollled)	30605
4	Exhaust Temp	SMD_BAS_IP_HTR_04_6]	✓	AV:606	Data Float	112	nvoHTR_04_7	inc count (9)	Output (non-pollled)	30606
4	Air Temp	SMD_BAS_IP_HTR_04_7]	✓	AV:607	Data Float	113	nvoHTR_04_8	inc count (9)	Output (non-pollled)	30607
4	Flame Strength	SMD_BAS_IP_HTR_04_8]	✓	AV:608	Data Float	114	nvoHTR_04_9	inc count (9)	Output (non-pollled)	30608
4	Fire Rate In	SMD_BAS_IP_HTR_04_9]	✓	AV:609	Data Float	115	nvoHTR_04_10	inc count (9)	Output (non-pollled)	30609
4	Fire Rate Out	SMD_BAS_IP_HTR_04_10]	✓	AV:610	Data Float	116	nvoHTR_04_11	inc count (9)	Output (non-pollled)	30610
4	Unit Type	SMD_BAS_IP_HTR_04_11]	✓	AV:611	Data Float	117	nvoHTR_04_12	inc count (9)	Output (non-pollled)	30611
4	Unit Size	SMD_BAS_IP_HTR_04_12]	✓	AV:612	Data Float	118	nvoHTR_04_13	inc count (9)	Output (non-pollled)	30612
4	Value State	SMD_BAS_IP_HTR_04_13]	✓	AV:613	Data Float	119	nvoHTR_04_14	inc count (9)	Output (non-pollled)	30613
4	Net Remote Setpt	SMD_BAS_IP_HTR_04_14]	✓	AV:614	Data Float	120	nvoHTR_04_15	inc count (9)	Output (non-pollled)	30614
4	Run Cycles Upper	SMD_BAS_IP_HTR_04_15]	✓	AV:615	Data Float	121	nvoHTR_04_16	inc count (9)	Output (non-pollled)	30615
4	Run Cycles Lower	SMD_BAS_IP_HTR_04_16]	✓	AV:616	Data Float	122	nvoHTR_04_17	inc count (9)	Output (non-pollled)	30616
4	Run Hours Upper	SMD_BAS_IP_HTR_04_17]	✓	AV:617	Data Float	123	nvoHTR_04_18	inc count (9)	Output (non-pollled)	30617
4	Run Hours Lower	SMD_BAS_IP_HTR_04_18]	✓	AV:618	Data Float	124	nvoHTR_04_19	inc count (9)	Output (non-pollled)	30618
4	Oxygen Level	SMD_BAS_IP_HTR_04_19]	✓	AV:619	Data Float	125	nvoHTR_04_20	inc count (9)	Output (non-pollled)	30619
Blr Addr 5										
5	Comm Address	SMD_BAS_IP_HTR_05_0]	✓	AV:700	Data Float	126	nvoHTR_05_1	inc count (9)	Output (non-pollled)	30700
5	Unit Status	SMD_BAS_IP_HTR_05_1]	✓	AV:701	Data Float	127	nvoHTR_05_2	inc count (9)	Output (non-pollled)	30701

Equip	Point Name	Name	Read Only	BACnet Type:ID	N2 Type	N2 ID	Lon NAME	Lon SNVT	Lon Direction	Modbus Address
5	Fault Code	SMD_BAS_IP_HTR_05_2]	✓	AV:702	Data Float	128	nvoHTR_05_3	inc count (9)	Output (non-pollled)	30702
5	Outlet Temp	SMD_BAS_IP_HTR_05_3]	✓	AV:703	Data Float	129	nvoHTR_05_4	inc count (9)	Output (non-pollled)	30703
5	FFWD Temp	SMD_BAS_IP_HTR_05_4]	✓	AV:704	Data Float	130	nvoHTR_05_5	inc count (9)	Output (non-pollled)	30704
5	Inlet Temp	SMD_BAS_IP_HTR_05_5]	✓	AV:705	Data Float	131	nvoHTR_05_6	inc count (9)	Output (non-pollled)	30705
5	Exhaust Temp	SMD_BAS_IP_HTR_05_6]	✓	AV:706	Data Float	132	nvoHTR_05_7	inc count (9)	Output (non-pollled)	30706
5	Air Temp	SMD_BAS_IP_HTR_05_7]	✓	AV:707	Data Float	133	nvoHTR_05_8	inc count (9)	Output (non-pollled)	30707
5	Flame Strength	SMD_BAS_IP_HTR_05_8]	✓	AV:708	Data Float	134	nvoHTR_05_9	inc count (9)	Output (non-pollled)	30708
5	Fire Rate In	SMD_BAS_IP_HTR_05_9]	✓	AV:709	Data Float	135	nvoHTR_05_10	inc count (9)	Output (non-pollled)	30709
5	Fire Rate Out	SMD_BAS_IP_HTR_05_10]	✓	AV:710	Data Float	136	nvoHTR_05_11	inc count (9)	Output (non-pollled)	30710
5	Unit Type	SMD_BAS_IP_HTR_05_11]	✓	AV:711	Data Float	137	nvoHTR_05_12	inc count (9)	Output (non-pollled)	30711
5	Unit Size	SMD_BAS_IP_HTR_05_12]	✓	AV:712	Data Float	138	nvoHTR_05_13	inc count (9)	Output (non-pollled)	30712
5	Value State	SMD_BAS_IP_HTR_05_13]	✓	AV:713	Data Float	139	nvoHTR_05_14	inc count (9)	Output (non-pollled)	30713
5	Net Remote Setpt	SMD_BAS_IP_HTR_05_14]	✓	AV:714	Data Float	140	nvoHTR_05_15	inc count (9)	Output (non-pollled)	30714
5	Run Cycles Upper	SMD_BAS_IP_HTR_05_15]	✓	AV:715	Data Float	141	nvoHTR_05_16	inc count (9)	Output (non-pollled)	30715
5	Run Cycles Lower	SMD_BAS_IP_HTR_05_16]	✓	AV:716	Data Float	142	nvoHTR_05_17	inc count (9)	Output (non-pollled)	30716
5	Run Hours Upper	SMD_BAS_IP_HTR_05_17]	✓	AV:717	Data Float	143	nvoHTR_05_18	inc count (9)	Output (non-pollled)	30717
5	Run Hours Lower	SMD_BAS_IP_HTR_05_18]	✓	AV:718	Data Float	144	nvoHTR_05_19	inc count (9)	Output (non-pollled)	30718
5	Oxygen Level	SMD_BAS_IP_HTR_05_19]	✓	AV:719	Data Float	145	nvoHTR_05_20	inc count (9)	Output (non-pollled)	30719
Blr Addr 6										
6	Comm Address	SMD_BAS_IP_HTR_06_0]	✓	AV:800	Data Float	146	nvoHTR_06_1	inc count (9)	Output (non-pollled)	30800
6	Unit Status	SMD_BAS_IP_HTR_06_1]	✓	AV:801	Data Float	147	nvoHTR_06_2	inc count (9)	Output (non-pollled)	30801
6	Fault Code	SMD_BAS_IP_HTR_06_2]	✓	AV:802	Data Float	148	nvoHTR_06_3	inc count (9)	Output (non-pollled)	30802
6	Outlet Temp	SMD_BAS_IP_HTR_06_3]	✓	AV:803	Data Float	149	nvoHTR_06_4	inc count (9)	Output (non-pollled)	30803
6	FFWD Temp	SMD_BAS_IP_HTR_06_4]	✓	AV:804	Data Float	150	nvoHTR_06_5	inc count (9)	Output (non-pollled)	30804
6	Inlet Temp	SMD_BAS_IP_HTR_06_5]	✓	AV:805	Data Float	151	nvoHTR_06_6	inc count (9)	Output (non-pollled)	30805
6	Exhaust Temp	SMD_BAS_IP_HTR_06_6]	✓	AV:806	Data Float	152	nvoHTR_06_7	inc count (9)	Output (non-pollled)	30806
6	Air Temp	SMD_BAS_IP_HTR_06_7]	✓	AV:807	Data Float	153	nvoHTR_06_8	inc count (9)	Output (non-pollled)	30807
6	Flame Strength	SMD_BAS_IP_HTR_06_8]	✓	AV:808	Data Float	154	nvoHTR_06_9	inc count (9)	Output (non-pollled)	30808
6	Fire Rate In	SMD_BAS_IP_HTR_06_9]	✓	AV:809	Data Float	155	nvoHTR_06_10	inc count (9)	Output (non-pollled)	30809
6	Fire Rate Out	SMD_BAS_IP_HTR_06_10]	✓	AV:810	Data Float	156	nvoHTR_06_11	inc count (9)	Output (non-pollled)	30810

Equip	Point Name	Name	Read Only	BACnet Type:ID	N2 Type	N2 ID	Lon NAME	Lon SNVT	Lon Direction	Modbus Address
6	Unit Type	SMD_BAS_IP_HTR_06_[11]	✓	AV:811	Data Float	157	nvoHTR_06_12	inc count (9)	Output (non-pollled)	30811
6	Unit Size	SMD_BAS_IP_HTR_06_[12]	✓	AV:812	Data Float	158	nvoHTR_06_13	inc count (9)	Output (non-pollled)	30812
6	Value State	SMD_BAS_IP_HTR_06_[13]	✓	AV:813	Data Float	159	nvoHTR_06_14	inc count (9)	Output (non-pollled)	30813
6	Net Remote Setpt	SMD_BAS_IP_HTR_06_[14]	✓	AV:814	Data Float	160	nvoHTR_06_15	inc count (9)	Output (non-pollled)	30814
6	Run Cycles Upper	SMD_BAS_IP_HTR_06_[15]	✓	AV:815	Data Float	161	nvoHTR_06_16	inc count (9)	Output (non-pollled)	30815
6	Run Cycles Lower	SMD_BAS_IP_HTR_06_[16]	✓	AV:816	Data Float	162	nvoHTR_06_17	inc count (9)	Output (non-pollled)	30816
6	Run Hours Upper	SMD_BAS_IP_HTR_06_[17]	✓	AV:817	Data Float	163	nvoHTR_06_18	inc count (9)	Output (non-pollled)	30817
6	Run Hours Lower	SMD_BAS_IP_HTR_06_[18]	✓	AV:818	Data Float	164	nvoHTR_06_19	inc count (9)	Output (non-pollled)	30818
6	Oxygen Level	SMD_BAS_IP_HTR_06_[19]	✓	AV:819	Data Float	165	nvoHTR_06_20	inc count (9)	Output (non-pollled)	30819
Blr Addr 7										
7	Comm Address	SMD_BAS_IP_HTR_07_[0]	✓	AV:900	Data Float	166	nvoHTR_07_1	inc count (9)	Output (non-pollled)	30900
7	Unit Status	SMD_BAS_IP_HTR_07_[1]	✓	AV:901	Data Float	167	nvoHTR_07_2	inc count (9)	Output (non-pollled)	30901
7	Fault Code	SMD_BAS_IP_HTR_07_[2]	✓	AV:902	Data Float	168	nvoHTR_07_3	inc count (9)	Output (non-pollled)	30902
7	Outlet Temp	SMD_BAS_IP_HTR_07_[3]	✓	AV:903	Data Float	169	nvoHTR_07_4	inc count (9)	Output (non-pollled)	30903
7	FFWD Temp	SMD_BAS_IP_HTR_07_[4]	✓	AV:904	Data Float	170	nvoHTR_07_5	inc count (9)	Output (non-pollled)	30904
7	Inlet Temp	SMD_BAS_IP_HTR_07_[5]	✓	AV:905	Data Float	171	nvoHTR_07_6	inc count (9)	Output (non-pollled)	30905
7	Exhaust Temp	SMD_BAS_IP_HTR_07_[6]	✓	AV:906	Data Float	172	nvoHTR_07_7	inc count (9)	Output (non-pollled)	30906
7	Air Temp	SMD_BAS_IP_HTR_07_[7]	✓	AV:907	Data Float	173	nvoHTR_07_8	inc count (9)	Output (non-pollled)	30907
7	Flame Strength	SMD_BAS_IP_HTR_07_[8]	✓	AV:908	Data Float	174	nvoHTR_07_9	inc count (9)	Output (non-pollled)	30908
7	Fire Rate In	SMD_BAS_IP_HTR_07_[9]	✓	AV:909	Data Float	175	nvoHTR_07_10	inc count (9)	Output (non-pollled)	30909
7	Fire Rate Out	SMD_BAS_IP_HTR_07_[10]	✓	AV:910	Data Float	176	nvoHTR_07_11	inc count (9)	Output (non-pollled)	30910
7	Unit Type	SMD_BAS_IP_HTR_07_[11]	✓	AV:911	Data Float	177	nvoHTR_07_12	inc count (9)	Output (non-pollled)	30911
7	Unit Size	SMD_BAS_IP_HTR_07_[12]	✓	AV:912	Data Float	178	nvoHTR_07_13	inc count (9)	Output (non-pollled)	30912
7	Value State	SMD_BAS_IP_HTR_07_[13]	✓	AV:913	Data Float	179	nvoHTR_07_14	inc count (9)	Output (non-pollled)	30913
7	Net Remote Setpt	SMD_BAS_IP_HTR_07_[14]	✓	AV:914	Data Float	180	nvoHTR_07_15	inc count (9)	Output (non-pollled)	30914
7	Run Cycles Upper	SMD_BAS_IP_HTR_07_[15]	✓	AV:915	Data Float	181	nvoHTR_07_16	inc count (9)	Output (non-pollled)	30915
7	Run Cycles Lower	SMD_BAS_IP_HTR_07_[16]	✓	AV:916	Data Float	182	nvoHTR_07_17	inc count (9)	Output (non-pollled)	30916
7	Run Hours Upper	SMD_BAS_IP_HTR_07_[17]	✓	AV:917	Data Float	183	nvoHTR_07_18	inc count (9)	Output (non-pollled)	30917

Equip	Point Name	Name	Read Only	BACnet Type:ID	N2 Type	N2 ID	Lon NAME	Lon SNVT	Lon Direction	Modbus Address
7	Run Hours Lower	SMD_BAS_IP_HTR_07_18	✓	AV:918	Data Float	184	nvoHTR_07_19	inc count (9)	Output (non-pollled)	30918
7	Oxygen Level	SMD_BAS_IP_HTR_07_19	✓	AV:919	Data Float	185	nvoHTR_07_20	inc count (9)	Output (non-pollled)	30919
Blr Addr 8										
8	Comm Address	SMD_BAS_IP_HTR_08_0	✓	AV:1000	Data Float	186	nvoHTR_08_1	inc count (9)	Output (non-pollled)	31000
8	Unit Status	SMD_BAS_IP_HTR_08_1	✓	AV:1001	Data Float	187	nvoHTR_08_2	inc count (9)	Output (non-pollled)	31001
8	Fault Code	SMD_BAS_IP_HTR_08_2	✓	AV:1002	Data Float	188	nvoHTR_08_3	inc count (9)	Output (non-pollled)	31002
8	Outlet Temp	SMD_BAS_IP_HTR_08_3	✓	AV:1003	Data Float	189	nvoHTR_08_4	inc count (9)	Output (non-pollled)	31003
8	FFWD Temp	SMD_BAS_IP_HTR_08_4	✓	AV:1004	Data Float	190	nvoHTR_08_5	inc count (9)	Output (non-pollled)	31004
8	Inlet Temp	SMD_BAS_IP_HTR_08_5	✓	AV:1005	Data Float	191	nvoHTR_08_6	inc count (9)	Output (non-pollled)	31005
8	Exhaust Temp	SMD_BAS_IP_HTR_08_6	✓	AV:1006	Data Float	192	nvoHTR_08_7	inc count (9)	Output (non-pollled)	31006
8	Air Temp	SMD_BAS_IP_HTR_08_7	✓	AV:1007	Data Float	193	nvoHTR_08_8	inc count (9)	Output (non-pollled)	31007
8	Flame Strength	SMD_BAS_IP_HTR_08_8	✓	AV:1008	Data Float	194	nvoHTR_08_9	inc count (9)	Output (non-pollled)	31008
8	Fire Rate In	SMD_BAS_IP_HTR_08_9	✓	AV:1009	Data Float	195	nvoHTR_08_10	inc count (9)	Output (non-pollled)	31009
8	Fire Rate Out	SMD_BAS_IP_HTR_08_10	✓	AV:1010	Data Float	196	nvoHTR_08_11	inc count (9)	Output (non-pollled)	31010
8	Unit Type	SMD_BAS_IP_HTR_08_11	✓	AV:1011	Data Float	197	nvoHTR_08_12	inc count (9)	Output (non-pollled)	31011
8	Unit Size	SMD_BAS_IP_HTR_08_12	✓	AV:1012	Data Float	198	nvoHTR_08_13	inc count (9)	Output (non-pollled)	31012
8	Value State	SMD_BAS_IP_HTR_08_13	✓	AV:1013	Data Float	199	nvoHTR_08_14	inc count (9)	Output (non-pollled)	31013
8	Net Remote Setpt	SMD_BAS_IP_HTR_08_14	✓	AV:1014	Data Float	200	nvoHTR_08_15	inc count (9)	Output (non-pollled)	31014
8	Run Cycles Upper	SMD_BAS_IP_HTR_08_15	✓	AV:1015	Data Float	201	nvoHTR_08_16	inc count (9)	Output (non-pollled)	31015
8	Run Cycles Lower	SMD_BAS_IP_HTR_08_16	✓	AV:1016	Data Float	202	nvoHTR_08_17	inc count (9)	Output (non-pollled)	31016
8	Run Hours Upper	SMD_BAS_IP_HTR_08_17	✓	AV:1017	Data Float	203	nvoHTR_08_18	inc count (9)	Output (non-pollled)	31017
8	Run Hours Lower	SMD_BAS_IP_HTR_08_18	✓	AV:1018	Data Float	204	nvoHTR_08_19	inc count (9)	Output (non-pollled)	31018
8	Oxygen Level	SMD_BAS_IP_HTR_08_19	✓	AV:1019	Data Float	205	nvoHTR_08_20	inc count (9)	Output (non-pollled)	31019
Blr Addr 9										
9	Comm Address	SMD_BAS_IP_HTR_09_0	✓	AV:1100	Data Float	206	nvoHTR_09_1	inc count (9)	Output (non-pollled)	31100
9	Unit Status	SMD_BAS_IP_HTR_09_1	✓	AV:1101	Data Float	207	nvoHTR_09_2	inc count (9)	Output (non-pollled)	31101
9	Fault Code	SMD_BAS_IP_HTR_09_2	✓	AV:1102	Data Float	208	nvoHTR_09_3	inc count (9)	Output (non-pollled)	31102
9	Outlet Temp	SMD_BAS_IP_HTR_09_3	✓	AV:1103	Data Float	209	nvoHTR_09_4	inc count (9)	Output (non-pollled)	31103
9	FFWD Temp	SMD_BAS_IP_HTR_09_4	✓	AV:1104	Data Float	210	nvoHTR_09_5	inc count (9)	Output (non-pollled)	31104

Equip	Point Name	Name	Read Only	BACnet Type:ID	N2 Type	N2 ID	Lon NAME	Lon SNVT	Lon Direction	Modbus Address
9	Inlet Temp	SMD_BAS_IP_HTR_09_05	✓	AV:1105	Data Float	211	nvoHTR_09_6	inc count (9)	Output (non-pollled)	31105
9	Exhaust Temp	SMD_BAS_IP_HTR_09_06	✓	AV:1106	Data Float	212	nvoHTR_09_7	inc count (9)	Output (non-pollled)	31106
9	Air Temp	SMD_BAS_IP_HTR_09_07	✓	AV:1107	Data Float	213	nvoHTR_09_8	inc count (9)	Output (non-pollled)	31107
9	Flame Strength	SMD_BAS_IP_HTR_09_08	✓	AV:1108	Data Float	214	nvoHTR_09_9	inc count (9)	Output (non-pollled)	31108
9	Fire Rate In	SMD_BAS_IP_HTR_09_09	✓	AV:1109	Data Float	215	nvoHTR_09_10	inc count (9)	Output (non-pollled)	31109
9	Fire Rate Out	SMD_BAS_IP_HTR_09_10	✓	AV:1110	Data Float	216	nvoHTR_09_11	inc count (9)	Output (non-pollled)	31110
9	Unit Type	SMD_BAS_IP_HTR_09_11	✓	AV:1111	Data Float	217	nvoHTR_09_12	inc count (9)	Output (non-pollled)	31111
9	Unit Size	SMD_BAS_IP_HTR_09_12	✓	AV:1112	Data Float	218	nvoHTR_09_13	inc count (9)	Output (non-pollled)	31112
9	Value State	SMD_BAS_IP_HTR_09_13	✓	AV:1113	Data Float	219	nvoHTR_09_14	inc count (9)	Output (non-pollled)	31113
9	Net Remote Setpt	SMD_BAS_IP_HTR_09_14	✓	AV:1114	Data Float	220	nvoHTR_09_15	inc count (9)	Output (non-pollled)	31114
9	Run Cycles Upper	SMD_BAS_IP_HTR_09_15	✓	AV:1115	Data Float	221	nvoHTR_09_16	inc count (9)	Output (non-pollled)	31115
9	Run Cycles Lower	SMD_BAS_IP_HTR_09_16	✓	AV:1116	Data Float	222	nvoHTR_09_17	inc count (9)	Output (non-pollled)	31116
9	Run Hours Upper	SMD_BAS_IP_HTR_09_17	✓	AV:1117	Data Float	223	nvoHTR_09_18	inc count (9)	Output (non-pollled)	31117
9	Run Hours Lower	SMD_BAS_IP_HTR_09_18	✓	AV:1118	Data Float	224	nvoHTR_09_19	inc count (9)	Output (non-pollled)	31118
9	Oxygen Level	SMD_BAS_IP_HTR_09_19	✓	AV:1119	Data Float	225	nvoHTR_09_20	inc count (9)	Output (non-pollled)	31119
9	Comm Address	SMD_BAS_IP_HTR_09_00	✓	AV:1100	Data Float	206	nvoHTR_09_1	inc count (9)	Output (non-pollled)	31100
Blr Addr 10										
10	Comm Address	SMD_BAS_IP_HTR_10_00	✓	AV:1200	Data Float	226	nvoHTR_10_1	inc count (9)	Output (non-pollled)	31200
10	Unit Status	SMD_BAS_IP_HTR_10_01	✓	AV:1201	Data Float	227	nvoHTR_10_2	inc count (9)	Output (non-pollled)	31201
10	Fault Code	SMD_BAS_IP_HTR_10_02	✓	AV:1202	Data Float	228	nvoHTR_10_3	inc count (9)	Output (non-pollled)	31202
10	Outlet Temp	SMD_BAS_IP_HTR_10_03	✓	AV:1203	Data Float	229	nvoHTR_10_4	inc count (9)	Output (non-pollled)	31203
10	FFWD Temp	SMD_BAS_IP_HTR_10_04	✓	AV:1204	Data Float	230	nvoHTR_10_5	inc count (9)	Output (non-pollled)	31204
10	Inlet Temp	SMD_BAS_IP_HTR_10_05	✓	AV:1205	Data Float	231	nvoHTR_10_6	inc count (9)	Output (non-pollled)	31205
10	Exhaust Temp	SMD_BAS_IP_HTR_10_06	✓	AV:1206	Data Float	232	nvoHTR_10_7	inc count (9)	Output (non-pollled)	31206
10	Air Temp	SMD_BAS_IP_HTR_10_07	✓	AV:1207	Data Float	233	nvoHTR_10_8	inc count (9)	Output (non-pollled)	31207
10	Flame Strength	SMD_BAS_IP_HTR_10_08	✓	AV:1208	Data Float	234	nvoHTR_10_9	inc count (9)	Output (non-pollled)	31208
10	Fire Rate In	SMD_BAS_IP_HTR_10_09	✓	AV:1209	Data Float	235	nvoHTR_10_10	inc count (9)	Output (non-pollled)	31209
10	Fire Rate Out	SMD_BAS_IP_HTR_10_10	✓	AV:1210	Data Float	236	nvoHTR_10_11	inc count (9)	Output (non-pollled)	31210
10	Unit Type	SMD_BAS_IP_HTR_10_11	✓	AV:1211	Data Float	237	nvoHTR_10_12	inc count (9)	Output (non-pollled)	31211
10	Unit Size	SMD_BAS_IP_HTR_10_12	✓	AV:1212	Data Float	238	nvoHTR_10_13	inc count (9)	Output (non-pollled)	31212

Equip	Point Name	Name	Read Only	BACnet Type:ID	N2 Type	N2 ID	Lon NAME	Lon SNVT	Lon Direction	Modbus Address
10	Value State	SMD_BAS_IP_HTR_10_[13]	✓	AV:1213	Data Float	239	nvoHTR_10_14	inc count (9)	Output (non-pollled)	31213
10	Net Remote Setpt	SMD_BAS_IP_HTR_10_[14]	✓	AV:1214	Data Float	240	nvoHTR_10_15	inc count (9)	Output (non-pollled)	31214
10	Run Cycles Upper	SMD_BAS_IP_HTR_10_[15]	✓	AV:1215	Data Float	241	nvoHTR_10_16	inc count (9)	Output (non-pollled)	31215
10	Run Cycles Lower	SMD_BAS_IP_HTR_10_[16]	✓	AV:1216	Data Float	242	nvoHTR_10_17	inc count (9)	Output (non-pollled)	31216
10	Run Hours Upper	SMD_BAS_IP_HTR_10_[17]	✓	AV:1217	Data Float	243	nvoHTR_10_18	inc count (9)	Output (non-pollled)	31217
10	Run Hours Lower	SMD_BAS_IP_HTR_10_[18]	✓	AV:1218	Data Float	244	nvoHTR_10_19	inc count (9)	Output (non-pollled)	31218
10	Oxygen Level	SMD_BAS_IP_HTR_10_[19]	✓	AV:1219	Data Float	245	nvoHTR_10_20	inc count (9)	Output (non-pollled)	31219
Blr Addr 11										
11	Comm Address	SMD_BAS_IP_HTR_11_[0]	✓	AV:1300	Data Float	246	nvoHTR_11_1	inc count (9)	Output (non-pollled)	31300
11	Unit Status	SMD_BAS_IP_HTR_11_[1]	✓	AV:1301	Data Float	247	nvoHTR_11_2	inc count (9)	Output (non-pollled)	31301
11	Fault Code	SMD_BAS_IP_HTR_11_[2]	✓	AV:1302	Data Float	248	nvoHTR_11_3	inc count (9)	Output (non-pollled)	31302
11	Outlet Temp	SMD_BAS_IP_HTR_11_[3]	✓	AV:1303	Data Float	249	nvoHTR_11_4	inc count (9)	Output (non-pollled)	31303
11	FFWD Temp	SMD_BAS_IP_HTR_11_[4]	✓	AV:1304	Data Float	250	nvoHTR_11_5	inc count (9)	Output (non-pollled)	31304
11	Inlet Temp	SMD_BAS_IP_HTR_11_[5]	✓	AV:1305	Data Float	251	nvoHTR_11_6	inc count (9)	Output (non-pollled)	31305
11	Exhaust Temp	SMD_BAS_IP_HTR_11_[6]	✓	AV:1306	Data Float	252	nvoHTR_11_7	inc count (9)	Output (non-pollled)	31306
11	Air Temp	SMD_BAS_IP_HTR_11_[7]	✓	AV:1307	Data Float	253	nvoHTR_11_8	inc count (9)	Output (non-pollled)	31307
11	Flame Strength	SMD_BAS_IP_HTR_11_[8]	✓	AV:1308	Data Float	254	nvoHTR_11_9	inc count (9)	Output (non-pollled)	31308
11	Fire Rate In	SMD_BAS_IP_HTR_11_[9]	✓	AV:1309	Data Float	255	nvoHTR_11_10	inc count (9)	Output (non-pollled)	31309
11	Fire Rate Out	SMD_BAS_IP_HTR_11_[10]	✓	AV:1310	Data Float	256	nvoHTR_11_11	inc count (9)	Output (non-pollled)	31310
11	Unit Type	SMD_BAS_IP_HTR_11_[11]	✓	AV:1311	Data Float	257	nvoHTR_11_12	inc count (9)	Output (non-pollled)	31311
11	Unit Size	SMD_BAS_IP_HTR_11_[12]	✓	AV:1312	Data Float	258	nvoHTR_11_13	inc count (9)	Output (non-pollled)	31312
11	Value State	SMD_BAS_IP_HTR_11_[13]	✓	AV:1313	Data Float	259	nvoHTR_11_14	inc count (9)	Output (non-pollled)	31313
11	Net Remote Setpt	SMD_BAS_IP_HTR_11_[14]	✓	AV:1314	Data Float	260	nvoHTR_11_15	inc count (9)	Output (non-pollled)	31314
11	Run Cycles Upper	SMD_BAS_IP_HTR_11_[15]	✓	AV:1315	Data Float	261	nvoHTR_11_16	inc count (9)	Output (non-pollled)	31315
11	Run Cycles Lower	SMD_BAS_IP_HTR_11_[16]	✓	AV:1316	Data Float	262	nvoHTR_11_17	inc count (9)	Output (non-pollled)	31316
11	Run Hours Upper	SMD_BAS_IP_HTR_11_[17]	✓	AV:1317	Data Float	263	nvoHTR_11_18	inc count (9)	Output (non-pollled)	31317
11	Run Hours Lower	SMD_BAS_IP_HTR_11_[18]	✓	AV:1318	Data Float	264	nvoHTR_11_19	inc count (9)	Output (non-pollled)	31318
11	Oxygen Level	SMD_BAS_IP_HTR_11_[19]	✓	AV:1319	Data Float	265	nvoHTR_11_20	inc count (9)	Output (non-pollled)	31319

Equip	Point Name	Name	Read Only	BACnet Type:ID	N2 Type	N2 ID	Lon NAME	Lon SNVT	Lon Direction	Modbus Address
Blr Addr 12										
12	Comm Address	SMD_BAS_IP_HTR_12_0]	✓	AV:1400	Data Float	266	nvoHTR_12_1	inc count (9)	Output (non-pollled)	31400
12	Unit Status	SMD_BAS_IP_HTR_12_1]	✓	AV:1401	Data Float	267	nvoHTR_12_2	inc count (9)	Output (non-pollled)	31401
12	Fault Code	SMD_BAS_IP_HTR_12_2]	✓	AV:1402	Data Float	268	nvoHTR_12_3	inc count (9)	Output (non-pollled)	31402
12	Outlet Temp	SMD_BAS_IP_HTR_12_3]	✓	AV:1403	Data Float	269	nvoHTR_12_4	inc count (9)	Output (non-pollled)	31403
12	FFWD Temp	SMD_BAS_IP_HTR_12_4]	✓	AV:1404	Data Float	270	nvoHTR_12_5	inc count (9)	Output (non-pollled)	31404
12	Inlet Temp	SMD_BAS_IP_HTR_12_5]	✓	AV:1405	Data Float	271	nvoHTR_12_6	inc count (9)	Output (non-pollled)	31405
12	Exhaust Temp	SMD_BAS_IP_HTR_12_6]	✓	AV:1406	Data Float	272	nvoHTR_12_7	inc count (9)	Output (non-pollled)	31406
12	Air Temp	SMD_BAS_IP_HTR_12_7]	✓	AV:1407	Data Float	273	nvoHTR_12_8	inc count (9)	Output (non-pollled)	31407
12	Flame Strength	SMD_BAS_IP_HTR_12_8]	✓	AV:1408	Data Float	274	nvoHTR_12_9	inc count (9)	Output (non-pollled)	31408
12	Fire Rate In	SMD_BAS_IP_HTR_12_9]	✓	AV:1409	Data Float	275	nvoHTR_12_10	inc count (9)	Output (non-pollled)	31409
12	Fire Rate Out	SMD_BAS_IP_HTR_12_10]	✓	AV:1410	Data Float	276	nvoHTR_12_11	inc count (9)	Output (non-pollled)	31410
12	Unit Type	SMD_BAS_IP_HTR_12_11]	✓	AV:1411	Data Float	277	nvoHTR_12_12	inc count (9)	Output (non-pollled)	31411
12	Unit Size	SMD_BAS_IP_HTR_12_12]	✓	AV:1412	Data Float	278	nvoHTR_12_13	inc count (9)	Output (non-pollled)	31412
12	Value State	SMD_BAS_IP_HTR_12_13]	✓	AV:1413	Data Float	279	nvoHTR_12_14	inc count (9)	Output (non-pollled)	31413
12	Net Remote Setpt	SMD_BAS_IP_HTR_12_14]	✓	AV:1414	Data Float	280	nvoHTR_12_15	inc count (9)	Output (non-pollled)	31414
12	Run Cycles Upper	SMD_BAS_IP_HTR_12_15]	✓	AV:1415	Data Float	281	nvoHTR_12_16	inc count (9)	Output (non-pollled)	31415
12	Run Cycles Lower	SMD_BAS_IP_HTR_12_16]	✓	AV:1416	Data Float	282	nvoHTR_12_17	inc count (9)	Output (non-pollled)	31416
12	Run Hours Upper	SMD_BAS_IP_HTR_12_17]	✓	AV:1417	Data Float	283	nvoHTR_12_18	inc count (9)	Output (non-pollled)	31417
12	Run Hours Lower	SMD_BAS_IP_HTR_12_18]	✓	AV:1418	Data Float	284	nvoHTR_12_19	inc count (9)	Output (non-pollled)	31418
12	Oxygen Level	SMD_BAS_IP_HTR_12_19]	✓	AV:1419	Data Float	285	nvoHTR_12_20	inc count (9)	Output (non-pollled)	31419
Blr Addr 13										
13	Comm Address	SMD_BAS_IP_HTR_13_0]	✓	AV:1500	Data Float	286	nvoHTR_13_1	inc count (9)	Output (non-pollled)	31500
13	Unit Status	SMD_BAS_IP_HTR_13_1]	✓	AV:1501	Data Float	287	nvoHTR_13_2	inc count (9)	Output (non-pollled)	31501
13	Fault Code	SMD_BAS_IP_HTR_13_2]	✓	AV:1502	Data Float	288	nvoHTR_13_3	inc count (9)	Output (non-pollled)	31502
13	Outlet Temp	SMD_BAS_IP_HTR_13_3]	✓	AV:1503	Data Float	289	nvoHTR_13_4	inc count (9)	Output (non-pollled)	31503
13	FFWD Temp	SMD_BAS_IP_HTR_13_4]	✓	AV:1504	Data Float	290	nvoHTR_13_5	inc count (9)	Output (non-pollled)	31504
13	Inlet Temp	SMD_BAS_IP_HTR_13_5]	✓	AV:1505	Data Float	291	nvoHTR_13_6	inc count (9)	Output (non-pollled)	31505
13	Exhaust Temp	SMD_BAS_IP_HTR_13_6]	✓	AV:1506	Data Float	292	nvoHTR_13_7	inc count (9)	Output (non-pollled)	31506
13	Air Temp	SMD_BAS_IP_HTR_13_7]	✓	AV:1507	Data Float	293	nvoHTR_13_8	inc count (9)	Output (non-pollled)	31507

Equip	Point Name	Name	Read Only	BACnet Type:ID	N2 Type	N2 ID	Lon NAME	Lon SNVT	Lon Direction	Modbus Address
13	Flame Strength	SMD_BAS_IP_HTR_13_ [8]	✓	AV:1508	Data Float	294	nvoHTR_13_9	inc count (9)	Output (non-pollled)	31508
13	Fire Rate In	SMD_BAS_IP_HTR_13_ [9]	✓	AV:1509	Data Float	295	nvoHTR_13_10	inc count (9)	Output (non-pollled)	31509
13	Fire Rate Out	SMD_BAS_IP_HTR_13_ [10]	✓	AV:1510	Data Float	296	nvoHTR_13_11	inc count (9)	Output (non-pollled)	31510
13	Unit Type	SMD_BAS_IP_HTR_13_ [11]	✓	AV:1511	Data Float	297	nvoHTR_13_12	inc count (9)	Output (non-pollled)	31511
13	Unit Size	SMD_BAS_IP_HTR_13_ [12]	✓	AV:1512	Data Float	298	nvoHTR_13_13	inc count (9)	Output (non-pollled)	31512
13	Value State	SMD_BAS_IP_HTR_13_ [13]	✓	AV:1513	Data Float	299	nvoHTR_13_14	inc count (9)	Output (non-pollled)	31513
13	Net Remote Setpt	SMD_BAS_IP_HTR_13_ [14]	✓	AV:1514	Data Float	300	nvoHTR_13_15	inc count (9)	Output (non-pollled)	31514
13	Run Cycles Upper	SMD_BAS_IP_HTR_13_ [15]	✓	AV:1515	Data Float	301	nvoHTR_13_16	inc count (9)	Output (non-pollled)	31515
13	Run Cycles Lower	SMD_BAS_IP_HTR_13_ [16]	✓	AV:1516	Data Float	302	nvoHTR_13_17	inc count (9)	Output (non-pollled)	31516
13	Run Hours Upper	SMD_BAS_IP_HTR_13_ [17]	✓	AV:1517	Data Float	303	nvoHTR_13_18	inc count (9)	Output (non-pollled)	31517
13	Run Hours Lower	SMD_BAS_IP_HTR_13_ [18]	✓	AV:1518	Data Float	304	nvoHTR_13_19	inc count (9)	Output (non-pollled)	31518
13	Oxygen Level	SMD_BAS_IP_HTR_13_ [19]	✓	AV:1519	Data Float	305	nvoHTR_13_20	inc count (9)	Output (non-pollled)	31519
Blr Addr 14										
14	Comm Address	SMD_BAS_IP_HTR_14_ [0]	✓	AV:1600	Data Float	306	nvoHTR_14_1	inc count (9)	Output (non-pollled)	31600
14	Unit Status	SMD_BAS_IP_HTR_14_ [1]	✓	AV:1601	Data Float	307	nvoHTR_14_2	inc count (9)	Output (non-pollled)	31601
14	Fault Code	SMD_BAS_IP_HTR_14_ [2]	✓	AV:1602	Data Float	308	nvoHTR_14_3	inc count (9)	Output (non-pollled)	31602
14	Outlet Temp	SMD_BAS_IP_HTR_14_ [3]	✓	AV:1603	Data Float	309	nvoHTR_14_4	inc count (9)	Output (non-pollled)	31603
14	FFWD Temp	SMD_BAS_IP_HTR_14_ [4]	✓	AV:1604	Data Float	310	nvoHTR_14_5	inc count (9)	Output (non-pollled)	31604
14	Inlet Temp	SMD_BAS_IP_HTR_14_ [5]	✓	AV:1605	Data Float	311	nvoHTR_14_6	inc count (9)	Output (non-pollled)	31605
14	Exhaust Temp	SMD_BAS_IP_HTR_14_ [6]	✓	AV:1606	Data Float	312	nvoHTR_14_7	inc count (9)	Output (non-pollled)	31606
14	Air Temp	SMD_BAS_IP_HTR_14_ [7]	✓	AV:1607	Data Float	313	nvoHTR_14_8	inc count (9)	Output (non-pollled)	31607
14	Flame Strength	SMD_BAS_IP_HTR_14_ [8]	✓	AV:1608	Data Float	314	nvoHTR_14_9	inc count (9)	Output (non-pollled)	31608
14	Fire Rate In	SMD_BAS_IP_HTR_14_ [9]	✓	AV:1609	Data Float	315	nvoHTR_14_10	inc count (9)	Output (non-pollled)	31609
14	Fire Rate Out	SMD_BAS_IP_HTR_14_ [10]	✓	AV:1610	Data Float	316	nvoHTR_14_11	inc count (9)	Output (non-pollled)	31610
14	Unit Type	SMD_BAS_IP_HTR_14_ [11]	✓	AV:1611	Data Float	317	nvoHTR_14_12	inc count (9)	Output (non-pollled)	31611
14	Unit Size	SMD_BAS_IP_HTR_14_ [12]	✓	AV:1612	Data Float	318	nvoHTR_14_13	inc count (9)	Output (non-pollled)	31612
14	Value State	SMD_BAS_IP_HTR_14_ [13]	✓	AV:1613	Data Float	319	nvoHTR_14_14	inc count (9)	Output (non-pollled)	31613
14	Net Remote Setpt	SMD_BAS_IP_HTR_14_ [14]	✓	AV:1614	Data Float	320	nvoHTR_14_15	inc count (9)	Output (non-pollled)	31614
14	Run Cycles Upper	SMD_BAS_IP_HTR_14_ [15]	✓	AV:1615	Data Float	321	nvoHTR_14_16	inc count (9)	Output (non-pollled)	31615

Equip	Point Name	Name	Read Only	BACnet Type:ID	N2 Type	N2 ID	Lon NAME	Lon SNVT	Lon Direction	Modbus Address
14	Run Cycles Lower	SMD_BAS_IP_HTR_14_[16]	✓	AV:1616	Data Float	322	nvoHTR_14_17	inc count (9)	Output (non-pollled)	31616
14	Run Hours Upper	SMD_BAS_IP_HTR_14_[17]	✓	AV:1617	Data Float	323	nvoHTR_14_18	inc count (9)	Output (non-pollled)	31617
14	Run Hours Lower	SMD_BAS_IP_HTR_14_[18]	✓	AV:1618	Data Float	324	nvoHTR_14_19	inc count (9)	Output (non-pollled)	31618
14	Oxygen Level	SMD_BAS_IP_HTR_14_[19]	✓	AV:1619	Data Float	325	nvoHTR_14_20	inc count (9)	Output (non-pollled)	31619
Blr Addr 15										
15	Comm Address	SMD_BAS_IP_HTR_15_[0]	✓	AV:1700	Data Float	326	nvoHTR_15_1	inc count (9)	Output (non-pollled)	31700
15	Unit Status	SMD_BAS_IP_HTR_15_[1]	✓	AV:1701	Data Float	327	nvoHTR_15_2	inc count (9)	Output (non-pollled)	31701
15	Fault Code	SMD_BAS_IP_HTR_15_[2]	✓	AV:1702	Data Float	328	nvoHTR_15_3	inc count (9)	Output (non-pollled)	31702
15	Outlet Temp	SMD_BAS_IP_HTR_15_[3]	✓	AV:1703	Data Float	329	nvoHTR_15_4	inc count (9)	Output (non-pollled)	31703
15	FFWD Temp	SMD_BAS_IP_HTR_15_[4]	✓	AV:1704	Data Float	330	nvoHTR_15_5	inc count (9)	Output (non-pollled)	31704
15	Inlet Temp	SMD_BAS_IP_HTR_15_[5]	✓	AV:1705	Data Float	331	nvoHTR_15_6	inc count (9)	Output (non-pollled)	31705
15	Exhaust Temp	SMD_BAS_IP_HTR_15_[6]	✓	AV:1706	Data Float	332	nvoHTR_15_7	inc count (9)	Output (non-pollled)	31706
15	Air Temp	SMD_BAS_IP_HTR_15_[7]	✓	AV:1707	Data Float	333	nvoHTR_15_8	inc count (9)	Output (non-pollled)	31707
15	Flame Strength	SMD_BAS_IP_HTR_15_[8]	✓	AV:1708	Data Float	334	nvoHTR_15_9	inc count (9)	Output (non-pollled)	31708
15	Fire Rate In	SMD_BAS_IP_HTR_15_[9]	✓	AV:1709	Data Float	335	nvoHTR_15_10	inc count (9)	Output (non-pollled)	31709
15	Fire Rate Out	SMD_BAS_IP_HTR_15_[10]	✓	AV:1710	Data Float	336	nvoHTR_15_11	inc count (9)	Output (non-pollled)	31710
15	Unit Type	SMD_BAS_IP_HTR_15_[11]	✓	AV:1711	Data Float	337	nvoHTR_15_12	inc count (9)	Output (non-pollled)	31711
15	Unit Size	SMD_BAS_IP_HTR_15_[12]	✓	AV:1712	Data Float	338	nvoHTR_15_13	inc count (9)	Output (non-pollled)	31712
15	Value State	SMD_BAS_IP_HTR_15_[13]	✓	AV:1713	Data Float	339	nvoHTR_15_14	inc count (9)	Output (non-pollled)	31713
15	Net Remote Setpt	SMD_BAS_IP_HTR_15_[14]	✓	AV:1714	Data Float	340	nvoHTR_15_15	inc count (9)	Output (non-pollled)	31714
15	Run Cycles Upper	SMD_BAS_IP_HTR_15_[15]	✓	AV:1715	Data Float	341	nvoHTR_15_16	inc count (9)	Output (non-pollled)	31715
15	Run Cycles Lower	SMD_BAS_IP_HTR_15_[16]	✓	AV:1716	Data Float	342	nvoHTR_15_17	inc count (9)	Output (non-pollled)	31716
15	Run Hours Upper	SMD_BAS_IP_HTR_15_[17]	✓	AV:1717	Data Float	343	nvoHTR_15_18	inc count (9)	Output (non-pollled)	31717
15	Run Hours Lower	SMD_BAS_IP_HTR_15_[18]	✓	AV:1718	Data Float	344	nvoHTR_15_19	inc count (9)	Output (non-pollled)	31718
15	Oxygen Level	SMD_BAS_IP_HTR_15_[19]	✓	AV:1719	Data Float	345	nvoHTR_15_20	inc count (9)	Output (non-pollled)	31719
Blr Addr 16										
16	Comm Address	SMD_BAS_IP_HTR_16_[0]	✓	AV:1800	Data Float	346	nvoHTR_16_1	inc count (9)	Output (non-pollled)	31800
16	Unit Status	SMD_BAS_IP_HTR_16_[1]	✓	AV:1801	Data Float	347	nvoHTR_16_2	inc count (9)	Output (non-pollled)	31801
16	Fault Code	SMD_BAS_IP_HTR_16_[2]	✓	AV:1802	Data Float	348	nvoHTR_16_3	inc count (9)	Output (non-pollled)	31802
16	Outlet Temp	SMD_BAS_IP_HTR_16_[3]	✓	AV:1803	Data Float	349	nvoHTR_16_4	inc count (9)	Output (non-pollled)	31803

Equip	Point Name	Name	Read Only	BACnet Type:ID	N2 Type	N2 ID	Lon NAME	Lon SNVT	Lon Direction	Modbus Address
16	FFWD Temp	SMD_BAS_IP_HTR_16_4	✓	AV:1804	Data Float	350	nvoHTR_16_5	inc count (9)	Output (non-pollled)	31804
16	Inlet Temp	SMD_BAS_IP_HTR_16_5	✓	AV:1805	Data Float	351	nvoHTR_16_6	inc count (9)	Output (non-pollled)	31805
16	Exhaust Temp	SMD_BAS_IP_HTR_16_6	✓	AV:1806	Data Float	352	nvoHTR_16_7	inc count (9)	Output (non-pollled)	31806
16	Air Temp	SMD_BAS_IP_HTR_16_7	✓	AV:1807	Data Float	353	nvoHTR_16_8	inc count (9)	Output (non-pollled)	31807
16	Flame Strength	SMD_BAS_IP_HTR_16_8	✓	AV:1808	Data Float	354	nvoHTR_16_9	inc count (9)	Output (non-pollled)	31808
16	Fire Rate In	SMD_BAS_IP_HTR_16_9	✓	AV:1809	Data Float	355	nvoHTR_16_10	inc count (9)	Output (non-pollled)	31809
16	Fire Rate Out	SMD_BAS_IP_HTR_16_10	✓	AV:1810	Data Float	356	nvoHTR_16_11	inc count (9)	Output (non-pollled)	31810
16	Unit Type	SMD_BAS_IP_HTR_16_11	✓	AV:1811	Data Float	357	nvoHTR_16_12	inc count (9)	Output (non-pollled)	31811
16	Unit Size	SMD_BAS_IP_HTR_16_12	✓	AV:1812	Data Float	358	nvoHTR_16_13	inc count (9)	Output (non-pollled)	31812
16	Value State	SMD_BAS_IP_HTR_16_13	✓	AV:1813	Data Float	359	nvoHTR_16_14	inc count (9)	Output (non-pollled)	31813
16	Net Remote Setpt	SMD_BAS_IP_HTR_16_14	✓	AV:1814	Data Float	360	nvoHTR_16_15	inc count (9)	Output (non-pollled)	31814
16	Run Cycles Upper	SMD_BAS_IP_HTR_16_15	✓	AV:1815	Data Float	361	nvoHTR_16_16	inc count (9)	Output (non-pollled)	31815
16	Run Cycles Lower	SMD_BAS_IP_HTR_16_16	✓	AV:1816	Data Float	362	nvoHTR_16_17	inc count (9)	Output (non-pollled)	31816
16	Run Hours Upper	SMD_BAS_IP_HTR_16_17	✓	AV:1817	Data Float	363	nvoHTR_16_18	inc count (9)	Output (non-pollled)	31817
16	Run Hours Lower	SMD_BAS_IP_HTR_16_18	✓	AV:1818	Data Float	364	nvoHTR_16_19	inc count (9)	Output (non-pollled)	31818
16	Oxygen Level	SMD_BAS_IP_HTR_16_19	✓	AV:1819	Data Float	365	nvoHTR_16_20	inc count (9)	Output (non-pollled)	31819
Master Addr 247										
Master Control Values										
247	Write Cntrl Val to BST/WHM	SMD_BAS_IP_Ctrl_1	* write "1" to send Value to WHM	AV:51	Data Float	2	nvoCtrl_2	inc count (9)	Input/Output	40051
247	BST/WHM Timeout	SMD_BAS_IP_Ctrl_3	**Read Only* *, 0=WHM Present, 1=WHM Absent	AV:53	Data Float	4	nvoCtrl_4	inc count (9)	Input/Output	40053
Read Master Operating Values										
247	Mode	SMD_BAS_IP_OpVal_0	✓	AV:100	Data Float	6	nvoOpVal_1	inc count (9)	Output (non-pollled)	30100
247	Setpoint	SMD_BAS_IP_OpVal_1	✓	AV:101	Data Float	7	nvoOpVal_2	inc count (9)	Output (non-pollled)	30101

Equip	Point Name	Name	Read Only	BACnet Type:ID	N2 Type	N2 ID	Lon NAME	Lon SNVT	Lon Direction	Modbus Address
247	Setback Setpt	SMD_BAS_IP_OpVal_[2]	✓	AV:102	Data Float	8	nvoOpVal_3	inc count (9)	Output (non-pollled)	30102
247	Setback Start	SMD_BAS_IP_OpVal_[3]	✓	AV:103	Data Float	9	nvoOpVal_4	inc count (9)	Output (non-pollled)	30103
247	Setback End	SMD_BAS_IP_OpVal_[4]	✓	AV:104	Data Float	10	nvoOpVal_5	inc count (9)	Output (non-pollled)	30104
247	Auto Master	SMD_BAS_IP_OpVal_[5]	✓	AV:105	Data Float	11	nvoOpVal_6	inc count (9)	Output (non-pollled)	30105
247	Avg Outlet Temp	SMD_BAS_IP_OpVal_[6]	✓	AV:106	Data Float	12	nvoOpVal_7	inc count (9)	Output (non-pollled)	30106
247	Units Active	SMD_BAS_IP_OpVal_[7]	✓	AV:107	Data Float	13	nvoOpVal_8	inc count (9)	Output (non-pollled)	30107
247	Units Faulted	SMD_BAS_IP_OpVal_[8]	✓	AV:108	Data Float	14	nvoOpVal_9	inc count (9)	Output (non-pollled)	30108
247	Master Addr	SMD_BAS_IP_OpVal_[9]	✓	AV:109	Data Float	15	nvoOpVal_10	inc count (9)	Output (non-pollled)	30109
247	Header Temp	SMD_BAS_IP_OpVal_[10]	✓	AV:110	Data Float	16	nvoOpVal_11	inc count (9)	Output (non-pollled)	30110
247	Outdoor Temp	SMD_BAS_IP_OpVal_[11]	✓	AV:111	Data Float	17	nvoOpVal_12	inc count (9)	Output (non-pollled)	30111
247	Percent Output	SMD_BAS_IP_OpVal_[12]	✓	AV:112	Data Float	18	nvoOpVal_13	inc count (9)	Output (non-pollled)	30112
247	Number of Units Firing	SMD_BAS_IP_OpVal_[13]	✓	AV:113	Data Float	19	nvoOpVal_14	inc count (9)	Output (non-pollled)	30113
247	Master Active Setpoint	SMD_BAS_IP_OpVal_[14]	✓	AV:114	Data Float	20	nvoOpVal_15	inc count (9)	Output (non-pollled)	30114
247	Next Turn-On Percent	SMD_BAS_IP_OpVal_[15]	✓	AV:115	Data Float	21	nvoOpVal_16	inc count (9)	Output (non-pollled)	30115
247	Header High Limit	SMD_BAS_IP_OpVal_[16]	✓	AV:116	Data Float	22	nvoOpVal_17	inc count (9)	Output (non-pollled)	30116
247	Header Low Limit	SMD_BAS_IP_OpVal_[17]	✓	AV:117	Data Float	23	nvoOpVal_18	inc count (9)	Output (non-pollled)	30117
247	Header Temp High Limit	SMD_BAS_IP_OpVal_[18]	✓	AV:118	Data Float	24	nvoOpVal_19	inc count (9)	Output (non-pollled)	30118
247	Header Setpoint Mode	SMD_BAS_IP_OpVal_[19]	✓	AV:119	Data Float	25	nvoOpVal_20	inc count (9)	Output (non-pollled)	30119
Write Master Operating Values										
247	Setpt	SMD_BAS_IP_CtrlVal_[0]		AV:200	Data Float	26	nvoCtrlVal_1	inc count (9)	Input (non-polling)	40200
247	Setback Setpt	SMD_BAS_IP_CtrlVal_[1]		AV:201	Data Float	27	nvoCtrlVal_2	inc count (9)	Input (non-polling)	40201
247	Setback Start	SMD_BAS_IP_CtrlVal_[2]		AV:202	Data Float	28	nvoCtrlVal_3	inc count (9)	Input (non-polling)	40202
247	Setback End	SMD_BAS_IP_CtrlVal_[3]		AV:203	Data Float	29	nvoCtrlVal_4	inc count (9)	Input (non-polling)	40203

NOTE: Writing a setpoint to WHM or BST is a two-step process. First write the setpoint to the “Write Setpoint” address. Next, write a “1” to the “Write Control” address. This will cause the ProtoAir to send the setpoint to the master C-More. After the setpoint is sent, this address value will change to “0” when read.

SmartPlate EV Points as a part of BST:

Htr Addr 50:

Point Name	BACnet Address	Lon Name	Lon SNVT	Modbus Reg. Type	Modbus Data Address
SP Outlet	AV: 3500	nvoSPHTR_50_1	SNVT_count_inc	Input	33500
SP Valve Position	AV: 3501	nvoSPHTR_50_2	SNVT_count_inc	Input	33501
SP Setpoint	AV: 3502	nvoSPHTR_50_3	SNVT_count_inc	Input	33502
SP Error #	AV: 3503	nvoSPHTR_50_4	SNVT_count_inc	Input	33503
SP Delta Pres	AV: 3504	nvoSPHTR_50_5	SNVT_count_inc	Input	33504
SP DHW Inlet	AV: 3505	nvoSPHTR_50_6	SNVT_count_inc	Input	33505
SP Flow	AV: 3506	nvoSPHTR_50_7	SNVT_count_inc	Input	33506
SP Boiler Inlet	AV: 3507	nvoSPHTR_50_8	SNVT_count_inc	Input	33507

Htr Addr 51:

Point Name	BACnet Address	Lon Name	Lon SNVT	Modbus Reg. Type	Modbus Data Address
SP Outlet	AV: 3600	nvoSPHTR_51_1	SNVT_count_inc	Input	33600
SP Valve Position	AV: 3601	nvoSPHTR_51_2	SNVT_count_inc	Input	33601
SP Setpoint	AV: 3602	nvoSPHTR_51_3	SNVT_count_inc	Input	33602
SP Error #	AV: 3603	nvoSPHTR_51_4	SNVT_count_inc	Input	33603
SP Delta Pres	AV: 3604	nvoSPHTR_51_5	SNVT_count_inc	Input	33604
SP DHW Inlet	AV: 3605	nvoSPHTR_51_6	SNVT_count_inc	Input	33605
SP Flow	AV: 3606	nvoSPHTR_51_7	SNVT_count_inc	Input	33606
SP Boiler Inlet	AV: 3607	nvoSPHTR_51_8	SNVT_count_inc	Input	33607

Htr Addr 52:

Point Name	BACnet Address	Lon Name	Lon SNVT	Modbus Reg. Type	Modbus Data Address
SP Outlet	AV: 3700	nvoSPHTR_52_1	SNVT_count_inc	Input	33700
SP Valve Position	AV: 3701	nvoSPHTR_52_2	SNVT_count_inc	Input	33701
SP Setpoint	AV: 3702	nvoSPHTR_52_3	SNVT_count_inc	Input	33702
SP Error #	AV: 3703	nvoSPHTR_52_4	SNVT_count_inc	Input	33703
SP Delta Pres	AV: 3704	nvoSPHTR_52_5	SNVT_count_inc	Input	33704
SP DHW Inlet	AV: 3705	nvoSPHTR_52_6	SNVT_count_inc	Input	33705
SP Flow	AV: 3706	nvoSPHTR_52_7	SNVT_count_inc	Input	33706
SP Boiler Inlet	AV: 3707	nvoSPHTR_52_8	SNVT_count_inc	Input	33707

Htr Addr 53:

Point Name	BACnet Address	Lon Name	Lon SNVT	Modbus Reg. Type	Modbus Data Address
SP Outlet	AV: 3800	nvoSPHTR_53_1	SNVT_count_inc	Input	33800
SP Valve Position	AV: 3801	nvoSPHTR_53_2	SNVT_count_inc	Input	33801
SP Setpoint	AV: 3802	nvoSPHTR_53_3	SNVT_count_inc	Input	33802
SP Error #	AV: 3803	nvoSPHTR_53_4	SNVT_count_inc	Input	33803
SP Delta Pres	AV: 3804	nvoSPHTR_53_5	SNVT_count_inc	Input	33804
SP DHW Inlet	AV: 3805	nvoSPHTR_53_6	SNVT_count_inc	Input	33805
SP Flow	AV: 3806	nvoSPHTR_53_7	SNVT_count_inc	Input	33806
SP Boiler Inlet	AV: 3807	nvoSPHTR_53_8	SNVT_count_inc	Input	33807

Htr Addr 54:

Point Name	BACnet Address	Lon Name	Lon SNVT	Modbus Reg. Type	Modbus Data Address
SP Outlet	AV: 3900	nvoSPHTR_54_1	SNVT_count_inc	Input	33900
SP Valve Position	AV: 3901	nvoSPHTR_54_2	SNVT_count_inc	Input	33901
SP Setpoint	AV: 3902	nvoSPHTR_54_3	SNVT_count_inc	Input	33902
SP Error #	AV: 3903	nvoSPHTR_54_4	SNVT_count_inc	Input	33903
SP Delta Pres	AV: 3904	nvoSPHTR_54_5	SNVT_count_inc	Input	33904
SP DHW Inlet	AV: 3905	nvoSPHTR_54_6	SNVT_count_inc	Input	33905
SP Flow	AV: 3906	nvoSPHTR_54_7	SNVT_count_inc	Input	33906
SP Boiler Inlet	AV: 3907	nvoSPHTR_54_8	SNVT_count_inc	Input	33907

Htr Addr 55:

Point Name	BACnet Address	Lon Name	Lon SNVT	Modbus Reg. Type	Modbus Data Address
SP Outlet	AV: 4000	nvoSPHTR_55_1	SNVT_count_inc	Input	34000
SP Valve Position	AV: 4001	nvoSPHTR_55_2	SNVT_count_inc	Input	34001
SP Setpoint	AV: 4002	nvoSPHTR_55_3	SNVT_count_inc	Input	34002
SP Error #	AV: 4003	nvoSPHTR_55_4	SNVT_count_inc	Input	34003
SP Delta Pres	AV: 4004	nvoSPHTR_55_5	SNVT_count_inc	Input	34004
SP DHW Inlet	AV:4005	nvoSPHTR_55_6	SNVT_count_inc	Input	34005
SP Flow	AV: 4006	nvoSPHTR_55_7	SNVT_count_inc	Input	34006
SP Boiler Inlet	AV: 4007	nvoSPHTR_55_8	SNVT_count_inc	Input	34007

11.4.C-More/Edge Status and Fault Messages

TABLE 6: Fault Codes			
Code	Message	Type	Description
0	NO FAULTS	n/a	
1	Disabled	Message	Indicates the Enable/Disable switch is set to Disabled . The display also shows the time (AM or PM) and date that the unit was disabled.
2	Standby	Message	Displayed when ON/OFF switch is in the ON position, but there is no demand for heat. The time and date are also displayed.
3	Demand Delay	Message	Displayed if Demand Delay is active.
4	Purging	Message	Displayed during the purge cycle during startup. The duration of the purge cycle counts up in seconds.
5	Ignition Trial	Message	Displayed during ignition trial of startup sequence. The duration of cycle counts up in seconds.
6	Flame Proven	Message	Displayed after flame has been detected for a period of 2 seconds. Initially, the flame strength is shown in %. After 5 seconds has elapsed, the time and date are shown in place of flame strength.
7	Warmup	Message	Displayed for 2 minutes during the initial warm-up only.
8	High Water Temp Switch Open	Fault, Reset	The High Water Temperature Limit Switch is open.
9	Low Water Level	Fault, Reset	The Water Level Control board is indicating low water level.
10	Low Gas Pressure Fault	Fault, Reset	The Low Gas Pressure Limit Switch is open.
11	Gas Pressure Fault	Fault, Reset	The High Gas Pressure Limit Switch is open.
12	Interlock Open	Fault	The Remote Interlock is open.
13	Delayed Interlock Open	Fault, Reset	The Delayed Interlock is open.
14	Airflow Fault During Purge	Fault, Reset	The Blower Proof Switch opened during purge.
15	SSOV Fault During Purge	Fault, Reset	The SSOV switch opened during purge.
16	Prg Switch Open During Purge	Fault, Reset	The Purge Position Limit switch on the Air/Fuel valve opened during purge.
17	Ign Switch Open During Ignition	Fault, Reset	The Ignition Position Limit switch on the Air/Fuel valve opened during ignition.
18	Airflow Fault During Ign	Fault	The Blower Proof Switch opened during ignition.
19	Airflow Fault During Run	Fault, Reset	The Blower Proof Switch opened during run.
20	SSOV Fault During Ignition	Fault, Reset	The SSOV switch closed or failed to open during ignition.
21	SSOV Fault During Run	Fault, Reset	The SSOV switch closed for more than 15 seconds during run.
22	Flame Loss During Ignition	Fault, Reset	The Flame signal was not seen during ignition or lost within 5 seconds after ignition.
23	Flame Loss During Run	Fault, Reset	The Flame signal was lost during run.
24	High Exhaust Temp Switch	Fault, Reset	The High Exhaust Temperature Limit Switch is closed.
25	Loss of Power	Fault	A power loss occurred. The time and date when power was restored is displayed.
26	Loss of Sensor	Not Used	Not Currently Used
27	Loss of Signal	Not Used	Not Currently Used
28	High O2 Level	Fault	Not Currently Used
29	Low O2 Level	Fault	Not Currently Used
30	High CO Level	Not Used	Not Currently Used

TABLE 6: Fault Codes			
Code	Message	Type	Description
31	SSOV Relay Failure	Fault, Reset	A failure has been detected in one of the relays that control the SSOV.
32	Residual Flame	Fault, Reset	The Flame signal was seen for more than 60 seconds during standby.
33	Heat Demand Failure	Fault, Reset	The Heat Demand Relays on the Ignition board failed to activate when commanded.
34	Ign Switch Closed During Purge	Fault, Reset	The Ignition Position Limit switch on the Air/Fuel valve closed during purge.
35	Prg Switch Closed During Ign	Fault, Reset	The Purge Position Limit switch on the Air/Fuel valve closed during ignition.
36	SSOV Switch Open	Fault, Reset	The SSOV switch opened during standby.
37	Ign Board Comm Fault	Fault	Communication fault between the Ignition board and the CPU board.
38	Wait	Message	Prompts the operator to wait.
39	Direct Drive Signal Fault	Fault	The direct drive signal is not present or is out of range.
40	Remote Setpt Signal Fault	Fault	The remote setpoint signal is not present or is out of range.
41	Outdoor Temp Sensor Fault	Fault	The temperature measured by the Outdoor Air Sensor is out of range.
42	Outlet Temp Sensor Fault	Fault	The temperature measured by the Outlet Sensor is out of range.
43	FFWD Temp Sensor Fault	Fault	The temperature measured by the FFWD Sensor is out of range.
44	High Water Temp	Fault	The temperature measured by the Outlet Sensor exceeded the Temp Hi Limit setting.
45	Line Voltage Out of Phase	Fault, Reset	The High AC voltage is out of phase from the low AC voltage.
46	Stepper Motor Failure	Fault, Reset	The stepper motor failed to move the valve to the desired position.
47	Setpoint Limiting Active	Fault	Setpoint temperature has exceeded the maximum allowable setting.
48	Modbus Comm Fault	Fault	The RS485 (Modbus) network information is not present or is corrupted.
49	Wait Ignition Retry	Message	Retrial for ignition.
50	WaitFault Purge	Message	Fault while purging.
51	Wait Retry Pause	Message	Pause before retrial for ignition.
52	Exhaust Temp Sensor Short	Warning	Exhaust temperature sensor is shorted.
53	Exhaust Temp Sensor Open	Warning	Exhaust temperature sensor is open or missing.
54	Warning Exhaust Temp High	Warning	Exhaust temperature is getting high.
55	Exhaust Temp High	Fault, Reset	Exhaust temperature is too high.
56	Inlet Water Temp Sensor Short	Warning	Inlet water temperature sensor is shorted.
57	Inlet Water Temp Sensor Open	Warning	Inlet water temperature sensor is open or missing.
58	Warning In Wtr Temp High	Warning	Inlet water temperature is getting too high.
59	Warning In Wtr Temp Low	Warning	Inlet water temperature is getting too low.
60	Inlet Gas Press Sensor Open	Fault	Inlet gas pressure switch is open.
61	Gas Plate Dp Sensor Open	Fault	Gas plate differential pressure switch is open.
62	O2 Percentage Low	Fault	Oxygen level is too low.
63	O2 Sensor Malfuction	Fault	Oxygen sensor reading is out of range.
64	Warning O2 Level High	Warning	Oxygen level is too high.
65	Recirc Pump Failure	Fault, Reset	Heater recirculation pump has malfunctioned.
66	Ignition Monitor	Message	Waiting for proof of ignition.

TABLE 6: Fault Codes			
Code	Message	Type	Description
67	No Flow Saftey Lockout	Not used	Flow input not registering when boiler is starting up.
68	Ignition Spark Fault	Fault, Reset	No ignition current measured when igniter is energized.
69	Pre Ignition	Message	Waiting for SSOV to prove open.
70	Cleaning Igniter	Message	Ignition transformer is energized with SSOV closed.
71	Too Many Cycles In 24 Hours	Fault	The number of cycles in 24 hour period has been exceeded.
72	Too Many Ovrtrmps In 24 Hours	Fault	The number of over temperature events in 24 hour period has been exceeded.
73	Air Sensor Fault	Fault	The inlet air sensor is out of range.
74	Auto Diagnostic Mode ACTIVE	Message	Informational message.
75	Auto Diagnostic Mode COMPLETED	Message	Informational message.
76	Auto Diagnostic Mode ABORTED	Message	Informational message.
77	DHW Heating Active	Message	Domestic Hot Water is enabled. Message shows when in combo mode with a fault in the drive signal.
78	Boiler Cooling Off	Message	Informational message during slow shutdown mode.
79	BST Network Temp Sensor Fault	Fault	The BST Modbus header temperature sensor is out of range.
80	BST Network Temp Com Fault	Fault	The BST Modbus failed to read the header temperature sensor.
81	BST Local Header Sensor Fault	Fault	The BST direct connected header temperature sensor is out of range.
82	BST Net Outdoor Sensor Fault	Fault	The BST Modbus connected outdoor air temperature sensor is out of range.
83	BST Net Outdoor Com Fault	Fault	The BST Modbus device failed to read the outdoor air sensor.
84	BST Local Outdr Sensor Fault	Fault	The BST direct connected outdoor air temperature sensor is out of range.
85	BST Client Com Fault	Message	Communication between BST Manager and BST Client failed
86	O2 Cal Purge	Message	O2 Purge in progress
87	Auto Calibration In Progress	Message	Auto Calibration In Progress
88	Autocal Finished	Warning	Autocal Finished
89	O2 Sensor Out Of Range	Warning	O2 sensor reading is out of range
90	O2 Warning Service Required	Message	O2 service is required
91	Wait Sensor Warm-up	Warning	O2 sensor is warming up
92	Air Pump Failed O2 Trim Disabled	Fault	O2 Trim was disabled due to air pump failuer (BMK 5000-6000 only)
93	onAER Communication failed	Warning	onAER communication failed
94	Isolation Valve Stuck Open	Warning	Isolation Valve Stuck Open
95	Isolation Valve Stuck Closed	Fault	Isolation Valve Stuck Closed
96	Maintenance Overdue	Warning	Periodic maintenance is overdue
97	Maintenance Due Soon	Warning	Periodic maintenance will be due soon
98	BAS System Disable	Warning	BAS system is disabled
99	Delta-T Activated	Warning	Delta-T is activated
100	Delta-T Shutdown	Warning	Delta-T has shutdown
101	BackUp Manager is not Compatible	Warning	Designated BST BackUp Manager is not compatible
102	IO Board Communication Failed	Warning	Communication with the I/O board failed
103	SH Swing Valve Fault	Warning	Space Heating side swing valve failed

TABLE 6: Fault Codes			
Code	Message	Type	Description
104	DHW Swing Valve Fault	Warning	Domestic hot water side swing valve failed
105	No BAS Communication	Warning	No communication from the Building Automation system after a period of 5 minutes
106	Warm Weather Shutdown	Warning	BST warm weather shutdown warning
107	Warm Weather Shutdown	Warning	Standalone warm weather shutdown warning
108	DHW Header Temp over BAS Fault	Warning	BAS failed to update the DHW temperature periodically
109	BST Header Temp over BAS Fault	Warning	BAS failed to update the BST header temperature periodically
110	Supply Return Temp over BAS Fault	Warning	BAS failed to update the supply return temperature periodically
111	Outdoor Temp over BAS Fault	Warning	BAS failed to update the outdoor temperature periodically
112	BST Return Sensor Short Warning	Warning	BST return sensor is shorted. Check the wirings.
113	BST Return Sensor Open Warning	Warning	BST return sensor is disconnected
114	DHW Header Network Sensor Fault	Warning	DHW header network sensor temperature is out of range.
115	DHW Header Network Comm Fault	Warning	No communication response from the DHW header network sensor
116	Supply Return Network Sensor Fault	Warning	Supply Return Network Sensor temperature is out of range.
117	Supply Return Network Comm Fault	Warning	No communication response from the supply return network sensor

11.5. Conversion Equations For Temperature Variables

**Table G-1: Conversion Equations for Temperature Variables
(Variable Counts to Temp)**

Register Variable Type	Degrees Fahrenheit (°F)	Degrees Celsius (°C)
DEGREES_1	$\text{Temp}(F) = \left[\frac{(\text{RegVar}) * (230) + 500}{1000} \right] + 20$	$\text{Temp}(C) = \left[\frac{(\text{RegVar}) * (128) + 500}{1000} \right] - 7$
DEGREES_2	$\text{Temp}(F) = \left[\frac{(\text{RegVar}) * (330) + 500}{1000} \right] - 80$	$\text{Temp}(C) = \left[\frac{(\text{RegVar}) * (183) + 500}{1000} \right] - 62$
DEGREES_3	$\text{Temp}(F) = \left[\frac{(\text{RegVar}) * (520) + 500}{1000} \right] + 40$	$\text{Temp}(C) = \left[\frac{(\text{RegVar}) * (289) + 500}{1000} \right] - 4$
ABS_DEG_1	<p>For (RegVar ≥ 0):</p> $\text{Temp}(F) = \left[\frac{(\text{RegVar}) * (230) + 500}{1000} \right]$ <p>For (RegVar < 0):</p> $\text{Temp}(F) = \left[\frac{(\text{RegVar}) * (230) - 500}{1000} \right]$	<p>For (RegVar ≥ 0):</p> $\text{Temp}(C) = \left[\frac{(\text{RegVar}) * (128) + 500}{1000} \right]$ <p>For (RegVar < 0):</p> $\text{Temp}(C) = \left[\frac{(\text{RegVar}) * (128) - 500}{1000} \right]$

**Table G-2: Conversion Equations for Temperature Variables
(Temp to Variable Counts)**

Register Variable Type	Degrees Fahrenheit (°F)	Degrees Celsius (°C)
DEGREES_1	$\text{RegVar} = \left[\frac{(\text{degF} - 20) * (1000) + 115}{230} \right]$	$\text{RegVar} = \left[\frac{(\text{degC} + 7) * (1000) + 64}{128} \right]$
DEGREES_2	$\text{RegVar} = \left[\frac{(\text{degF} + 80) * (1000) + 165}{330} \right]$	$\text{RegVar} = \left[\frac{(\text{degC} + 62) * (1000) + 91.5}{183} \right]$
DEGREES_3	$\text{RegVar} = \left[\frac{(\text{degF} - 40) * (1000) + 260}{652000} \right]$	$\text{RegVar} = \left[\frac{(\text{degC} - 4) * (1000) + 144.5}{289} \right]$
ABS_DEG_1	<p>For (degF > 0):</p> $\text{RegVar} = \left[\frac{(\text{degF}) * (1000) + 115}{230} \right]$ <p>For (degF < 0):</p> $\text{RegVar} = \left[\frac{(\text{degF}) * (1000) - 115}{230} \right]$	<p>For (degC > 0):</p> $\text{RegVar} = \left[\frac{(\text{degC}) * (1000) + 64}{128} \right]$ <p>For (degC < 0):</p> $\text{RegVar} = \left[\frac{(\text{degC}) * (1000) - 64}{128} \right]$

11.6.BCM and BMM Fault Codes For Modulex E8 Controller

11.6.1. BCM and BMM Fault Code Conversion Table

Table H-1, below, shows how to interpret the displayed fault code in the E8 Controller display, while Table H-2, on the next page, shows a description of the fault and troubleshooting tips associated with the BMMs. Table H-3, following, is for BCM faults.

In order to derive the correct error code from what is shown in the E8 Controller display, use Table H-1, below, to determine the working error code. To use the table, identify the displayed number from the first column, identify the affected module from the second column, apply the formula from the third column, and identify the Error Table to reference from the fourth column.

Table H-1: BCM and BMM Fault Code Conversion Table

Observed Code	Observed Code	Code to Look Up in	Table
Code = 0	N/A	No Fault	-
Code between 1 and 255	BMM #0 Fault	Look up code	F-2
Code between 256 and 511	BMM #1 Fault	Subtract 256 from reading	F-2
Code between 512 and 767	BMM #2 Fault	Subtract 512 from reading	F-2
Code between 768 and 1023	BMM #3 Fault	Subtract 768 from reading	F-2
Code between 1024 and 1279	BMM #4 Fault	Subtract 1024 from reading	F-2
Code between 1280 and 1535	BMM #5 Fault	Subtract 1280 from reading	F-2
Code between 1536 and 1791	BMM #6 Fault	Subtract 1536 from reading	F-2
Code between 1792 and 2047	BMM #7 Fault	Subtract 1792 from reading	F-2
Code between 2048 and 65279	N/A	Invalid Codes	-
Code above 65280	BCM Fault	Subtract 65280 from reading	F-2

Example:

Based on the above, a code reading of “261” means the fault occurred on BMM #1. The fault code is (261 – 256 =) 5. An Error Code of 5 from the BMM Fault Codes table means “Flame Loss During Run”.

11.6.2. BMM Fault Code Table

The table below lists the fault codes and troubleshooting tips associated with the BMM.

Table H-2: BMM Fault Code Table

Code	Description	Effect	Correction	Reset
1	High Limit (STB) Thermostat activated	All burners turned OFF and Pump ON at maximum speed.	Check FlowSensor thermal connection to boiler.	MANUAL - reset when temperature goes below limit.
2	Low Gas Pressure	All burners turned OFF.	Check gas pressure or gas pressure switch.	AUTOMATIC - when gas pressure switch closes.
4	No flame detected at burner start	Burner control lockout.	Check flame rod or combustion.	MANUAL - reset or cycle power.
5	Flame loss during run.	Ignition retry.	Check combustion and wiring.	MANUAL - reset or cycle power.

Table H-2: BMM Fault Code Table

Code	Description	Effect	Correction	Reset
6	High outlet temperature. FlowSensor temperature > 203°F.	All burners turned OFF and Pump ON at maximum speed.	Check Flow Sensor or system pump.	AUTOMATIC - when FlowSensor < 176°F.
10	Internal Failure	Ignition is inhibited.	Contact Factory for new BCM.	MANUAL - cycle the power.
11	Flame signal detected before ignition.	Ignition is inhibited.	Disconnect flame rod wire from BMM. If problem goes away change flame rod and/or wire. If problem does not go away change BMM.	MANUAL - reset or cycle power.
12	FlowSensor fault.	All burners turned OFF.	Check flow sensor or wiring.	AUTOMATIC
13	Aux Sensor fault	The boiler will operate from the FlowSensor without the AuxSensor.	Check aux sensor or wiring.	AUTOMATIC
14	Return Sensor fault	All burners turned OFF.	Check return sensor or wiring.	AUTOMATIC
15	Maximum Δ-temperature protection. Flow temperature - Return Temperature > Water Δ-Temp Protection + 50°F	All burners turned OFF and Pump ON at maximum speed.	Check the system installation.	AUTOMATIC - when Δ-temperature < Water Δ-Temp Protection.
16	Boiler Pipe is frozen. FlowSensor temperature is 36°F or less.	Ignition is inhibited. Pump runs for 5 min at max speed.	Carefully defrost boiler.	AUTOMATIC - when FlowSensor is greater than 41°F.
20	Flame signal detected after burner is OFF.	Ignition is inhibited.	Disconnect gas valve wire from BMM. If failure goes away, check wiring or change BMM. If failure remains check or change gas valve.	MANUAL - reset or cycle power.

Table H-2: BMM Fault Code Table

Code	Description	Effect	Correction	Reset
22	No air flow at burner after fan started for 30 seconds.	Ignition retry after 60 second delay and failure remains until we have a successful burner operation.	If fan is stopped, check supply voltage and fan wiring. If OK try another fan. If still not working change the BMM. If fan is not stopped, check the exhaust gas outlet for blockage. If OK then check the air pressure switch wiring. If still not working try another air pressure switch. If still not working, change the BMM.	AUTOMATIC/ MANUAL
23	The air pressure switch doesn't switch off.	Ignition is inhibited.	Disconnect the air proving switch. If problem goes away install a new switch. If not, check the wiring. If wiring OK then change BMM.	AUTOMATIC
24	Fan speed out of control: It doesn't reach pre-purge speed within 30 seconds.	Ignition retry after 60 second delay and failure remains until we have a successful burner operation.	Check fan wiring.	AUTOMATIC/ MANUAL
26	Fan speed out of control: It doesn't stop within 30 seconds after turned OFF.	Ignition is inhibited.	Check fan wiring.	AUTOMATIC
27	Air flow failure during ignition.	Restart pre-purge timer. The failure remains until we have a successful burner operation.	Check fan and wiring. Check air proving switch and wiring.	AUTOMATIC
28	Flue/Chimney Obstruction	Ignition is inhibited.	Check flue/chimney	
29	Water inside the combustion chamber.	Ignition is inhibited.	Check for water in the exhaust manifold	
30	Settings Corrupted	Ignition is inhibited. Pump runs for 5 min at max speed.	Re-program the settings. Contact Factory	MANUAL - cycle power or send reset message.
32	Line voltage too low. (<96 VAC)	Wait for proper line voltage. (>102 VAC)	Check input voltage else try another BMM.	AUTOMATIC
40	Low Water Flow. Low water flow switch activated.	Burners turned OFF.	Check water flow or check switch.	AUTOMATIC

11.6.3. BCM Fault Code Table

The table below lists the fault codes and troubleshooting tips associated with the BCM.

Table H-3: BCM Fault Code Table

Code	Description	Effect	Correction	Reset
17	Boiler Pipe is frozen. FlowSensor temp. is 36°F or less.	Ignition is inhibited. Pump runs for 5 min at max speed.	Carefully defrost boiler	AUTOMATIC - when FlowSensor is greater than 41°F.
18	Maximum Δ-temperature protection. Flow temperature - Return Temperature > Water Δ-Temp Protection + 50°F	All burners turned OFF and Pump ON at maximum speed.	Check the system installation.	AUTOMATIC - when Δ-temperature < Water Δ-Temp Protection.
19	High outlet temperature. FlowSensor temperature > 203°F.	All burners turned OFF and Pump ON at maximum speed.	Check Flow Sensor or system pump	AUTOMATIC - when FlowSensor < 176°F.
37	Crash	Ignition is inhibited	Change the BCM	MANUAL – reset to cycle power
38	Settings Corrupted	Ignition is inhibited. Pump runs for 5 min at max speed.	Re-program the settings. Contact Factory	MANUAL - reset or cycle power.
50	Internal Failure	Ignition is inhibited.	Contact Factory for new BCM.	MANUAL - cycle the power.
56	Standby. No remote control detected and Request input is open.	Ignition is inhibited.	Close Request input for Manual operation.	MANUAL - reset or cycle power.
57	No BMM detected.	Ignition is not possible.	Check the BMM eBus wiring.	MANUAL - reset or cycle power.
58	FlowSensor fault.	All burners turned OFF.	Check flow sensor or wiring.	AUTOMATIC

11.7.AM Error, State and Status Tables

11.7.1. AM Lockout Error Codes Table

Lockout errors are indicated by an ‘A’ displayed before the error code number.

“A” Lockout Error Codes			
‘A’ CODE	ERROR NAME	INT. #	DESCRIPTION
1	IGNIT_ERROR	1	Three unsuccessful ignition attempts in a row
2	GV Relay Error	2	Failure detected in the GV Relay
3	GV Relay not open error	3	Failure detected in the GV Relay
4	GV Relay not closing error	4	Failure detected in the GV Relay
5	Safety relay error	5	Failure detected in the Safety Relay
6	Safety relay open error	6	Failure detected in the Safety Relay
7	Safety relay closed error	7	Failure detected in the Safety Relay
11	Blocking too long error	11	Control had a blocking error for more than 20 hours in a row.
12	Fan error	12	Fan MF deviation for more than 60 sec
13	Ram error	13	Internal software error
14	Wrong eeprom signature	14	Contents of e2prom is not up-to-date
15	X ram error	15	Internal software error
16	E2prom error	16	No communication with E2prom
17	E2prom error safety C	17	Wrong safety parameters in e2prom
18	E2prom error Calibration table	18	Wrong calibration table parameters
19	State error	19	Internal software error
20	Rom error	20	Internal software error
21	Rom error C	21	Internal software error
22	Air sw not open	22	Air pressure switch not working
23	15MS XRL error	23	Internal software error
24	Air sw not closed	24	Air pressure switch not working
25	Max Temp. Error	25	The external overheat protection is activated
26	Stack error	26	Internal error
27	Flame out too late	27	Flame still present 10 sec. after closing the gas valve
28	Flame error 1	28	Flame is detected before ignition
29	20MS XRL error	29	Internal software error
30	41MS XRL error	30	Internal software error
31	Too many flame failures	31	Three times flame lost during one demand
32	Flow switch not closed	32	Flow switch not working / No flow
33	Flow switch not open	33	Flow switch not working / No flow
34	Flag byte integrity	34	Internal software error
35	AD Hi cpl.	35	Internal software error
36	AD Lo cpl.	36	Internal software error
37	Register error	37	Internal software error

11.7.2. AM Blocking Error Codes Table

The following errors are related to the general control functions. Blocking errors are indicated by an ‘E’ before the error code number.

“E” Blocking Error Codes			
‘E’ CODE	ERROR NAME	INT. #	DESCRIPTION
45	WD INTERNAL ERROR	45	Internal software error
46	WD INTERNAL ERROR	46	Internal software error
47	WD INTERNAL ERROR	47	Internal software error
48	WD INTERNAL ERROR	48	Internal software error
49	WD INTERNAL ERROR	49	Internal software error
50	REFHI TOO LO	50	Internal hardware error
51	REFHI TOO HI	51	Internal hardware error
52	REFLO TOO LO	52	Internal hardware error
53	REFLO TOO HI	53	Internal hardware error
54	FALSE FLAME	54	Flame is detected, but no flame is observed.
55	WATER LEVEL DETECT	55	Low water level detected
56	WATER LEVEL MEAS	56	Low water level measurement error
57	LOW WATER CUTOFF	57	Low water sensor error
58	LOW WATER PRESSURE	58	Low water pressure error
59	WATER PRESSURE SENSOR	59	Low water pressure
60	FLUE GAS PRESSURE	60	Flue gas pressure error
61	RETURN TEMP	61	Return temperature is higher than stay burning temperature
62	BLOCKED DRAIN	62	Block drain switch is active
64	WD FREQ ERROR	64	No Frequency signal or no communication with the WD
65	PHASE ERROR	65	Hot neutral reversed
66	NET FREQ ERROR	66	Net freq. error detected in the main
67	FAULTY EARTH ERROR	67	Faulty earth connection
68	WD COMM ERROR	68	Watchdog communication error
72	SUPPLY OPEN	72	Supply sensor open
73	RETURN OPEN	73	Return sensor open
76	DHW OPEN	76	DHW sensor open
80	SUPPLY SHORTED	80	Supply sensor shorted
81	RETURN SHORTED	81	Return sensor shorted
84	DHW SHORTED	84	DHW sensor shorted
86	FLUE SHORTED	86	Flue sensor shorted
87	RESET BUTTON	87	Reset button error
93	APPLIANCE SELECTION	93	Appliance selection error
107	GAS PRESSURE ERROR	107	Gas too low
108	FLUW PRESSURE ERROR	108	Flue gas pressure error
109	TRIO_MASTER_ERROR	109	Trio master error
110	FLAP_NOT_OPEN	110	Flap not open
111	FLAP_NOT_CLSD	111	Flap not closed
112	FLOW_SWT_NOT_CLSD_BL	112	Flow switch not closed
113	PASSWORD_INCORRECT	113	Password incorrect
114	TOO_LOW_WATER_FLOW	114	Water flow for CH is too low.
115	MULTI_BRN_PARAM_ERROR	115	Multiple burner settings are incorrect.

11.7.3. AM State Parameters Table

The table below lists a detailed description of the possible values of the STATE parameter.

MN States			
STATE		STATE NAME	DESCRIPTION
Dec.	Hex		
0	0x00	RESET_0	initialising
1	0x01	RESET_1	initialising
2	0x02	STANDBY_0	standing by (waiting for demand)
3	0x03	PRE_PURGE	initiating boiler demand handling
4	0x04	PRE_PURGE_1	initiating boiler demand handling
5	0x05	SAFETY_ON	initiating boiler demand handling
6	0x06	SAFETY_OFF	initiating boiler demand handling
7	0x07	IGNIT_0	initiating boiler demand handling
8	0x08	IGNIT_1	initiating boiler demand handling
9	0x09	BURN_0	handle boiler demand
10	0x0A	RELAY_TEST_0	
11	0x0B	RELAY_TEST_1	
12	0x0C	POST_PURGE_0	ending boiler demand handling
13	0x0D	POST_PURGE_1	ending boiler demand handling
14	0x0E	PUMP_CH_0	handling ch demand without boiler demand
15	0x0F	PUMP_CH_1	Post pumping after ch demand end
16	0x10	PUMP_HW_0	handling hw demand without boiler demand
17	0x11	PUMP_HW_1	Post pumping after dhw demand end
18	0x12	ALARM_1	Error handling
19	0x13	ERROR_CHECK	error handling
20	0x14	BURNER_BOOT	controller (re)start
21	0x15	CLEAR_E2PROM_ERROR	error handling
22	0x16	STORE_BLOCK_ERROR	error handling
23	0x17	WAIT_A_SECOND	error handling

11.7.4. AM Status Parameters Table

The STATUS parameter values are described below

MN Status			
STATUS		STATUS NAME	DESCRIPTION
Dec.	Hex		
0	0x00	STANDBY	standing by (waiting for demand)
14	0x0E	BLOCK	error handling
10	0x0A	ALARM	error handling
15	0x0F	FROST_PROTECT	demand for frost protection
16	0x10	CH	demand for central heating
17	0x11	RESET_STATE	initializing
18	0x12	STORAGE	demand for store
19	0x13	TAP	demand for tap (hw)
20	0x14	PRE_HEAT	demand for pre heat (of hw heat exchanger)
21	0x15	STORE_WARM_HOLD	demand for pre heat (of hw store)
22	0x16	GENERAL_PUMPING	

12. SPECIFICATIONS



ProtoAir FPA-W44	
Electrical Connections	One 3-pin Phoenix connector with: RS-485/RS-232 (Tx+ / Rx- / gnd) One 3-pin Phoenix connector with: RS-485 (+ / - / gnd) One 3-pin Phoenix connector with: Power port (+ / - / Frame-gnd) One Ethernet 10/100 BaseT port
Power Requirements	<i>Input Voltage:</i> 12-24VDC or 24VAC <i>Current draw:</i> 24VAC 0.125A <i>Max Power:</i> 3 Watts 12-24VDC 0.25A @12VDC
Approvals	FCC Part 15 C, IEC 62368-1, CAN/CSA C22.2 No. 60950-1, EN IEC 62368-1:2020+A11:2020, DNP 3.0 and Modbus conformance tested, BTL marked, WEEE compliant, RoHS compliant, REACH compliant, UKCA and CE compliant, ODVA conformant, CAN ICES-003(B) / NMB-003(B)
Physical Dimensions	4 x 1.1 x 2.7 in (10.16 x 2.8 x 6.8 cm)
Weight	0.4 lbs (0.2 Kg)
Operating Temperature	-20°C to 70°C (-4°F to 158°F)
Humidity	10-95% RH non-condensing
Wi-Fi 802.11 b/g/n	<i>Frequency:</i> 2.4 GHz <i>Channels:</i> 1 to 11 (inclusive) <i>Antenna Type:</i> SMA <i>Encryption:</i> TKIP, WPA2 & AES

NOTE: Specifications subject to change without notice.

12.1. Compliance with EN IEC 62368-1

For EN IEC compliance, the following instructions must be met when operating the ProtoAir.

- The units shall be powered by listed LPS or Class 2 power supply suited to the expected operating temperature range.
- The interconnecting power connector and power cable shall:
 - Comply with local electrical code
 - Be suited to the expected operating temperature range
 - Meet the current and voltage rating for the FieldServer
- Furthermore, the interconnecting power cable shall:
 - Be of length not exceeding 3.05m (118.3")
 - Be constructed of materials rated VW-1, FT-1 or better
- If the unit is to be installed in an operating environment with a temperature above 65 °C, it should be installed in a Restricted Access Area requiring a key or a special tool to gain access.
- This device must not be connected to a LAN segment with outdoor wiring.

12.2. Warnings for FCC and IC Waste Disposal

It is recommended to disassemble the device before abandoning it in conformity with local regulations. Please ensure that the abandoned batteries are disposed according to local regulations on waste disposal. Do not throw batteries into fire (explosive) or put in common waste canister. Products or product packages with the sign of “explosive” should not be disposed like household waste but delivered to specialized electrical & electronic waste recycling/disposal center. Proper disposal of this sort of waste helps avoiding harm and adverse effect upon surroundings and people’s health. Please contact local organizations or recycling/disposal center for more recycling/disposal methods of related products.

Comply with the following safety tips:

Do Not use in Combustible and Explosive Environment

Keep away from combustible and explosive environment for fear of danger. Keep away from all energized circuits.

Operators should not remove enclosure from the device. Only the group or person with factory certification is permitted to open the enclosure to adjust and replace the structure and components of the device. Do not change components unless the power cord is removed. In some cases, the device may still have residual voltage even if the power cord is removed. Therefore, it is a must to remove and fully discharge the device before contact so as to avoid injury.

Unauthorized Changes to this Product or its Components are Prohibited

In the aim of avoiding accidents as far as possible, it is not allowed to replace the system or change components unless with permission and certification. Please contact the technical department of AERCO or local branches for help.

Pay Attention to Caution Signs

Caution signs in this manual remind of possible danger. Please comply with relevant safety tips below each sign. Meanwhile, you should strictly conform to all safety tips for operation environment.

Notice

Considering that reasonable efforts have been made to assure accuracy of this manual, AERCO assumes no responsibility of possible missing contents and information, errors in contents, citations, examples, and source programs.

AERCO reserves the right to make necessary changes to this manual without prior notice. No part of this manual may be reprinted or publicly released.

FCC Warning

This device complies with FCC Rules. Operation is subject to the following conditions. This device may not cause harmful interference.

This device must accept any interference received, including interference that may cause undesired operation. This device complies with Part 15C of the FCC Rules

NOTE: This equipment has been tested and found to comply with the limits for a Class B digital device, pursuant to part 15 of the FCC Rules. These limits are designed to provide reasonable protection against harmful interference in a residential installation. This equipment generates, uses and can radiate radio frequency energy and, if not installed and used in accordance with the instructions, may cause harmful interference to radio communications. However, there is no guarantee that interference will not occur in a particular installation. If this equipment does cause harmful interference to radio or television reception, which can be determined by turning the equipment off and on, the user is encouraged to try to correct the interference by one or more of the following measures:

- Reorient or relocate the receiving antenna.
- Increase the separation between the equipment and receiver.
- Connect equipment into an outlet on a circuit different from which the receiver is connected.
- Consult the dealer or an experienced radio/TV technician for help.

Any modification to the product is not permitted unless authorized by MSA Safety. It's not allowed to disassemble the product; it is not allowed to replace the system or change components unless with permission and certification. Please contact the FieldServer technical support department or local branches for help.

IC Statement

This device complies with Industry Canada license-exempt RSS standard(s). Operation is subject to the following two conditions:

- This device may not cause interference, and
- This device must accept any interference, including interference that may cause undesired operation of the device.

Warning! This class B digital apparatus complies with Canadian ICES-003.

Industry Canada ICES-003 Compliance Label:

CAN ICES-3 (B)/NMB-3(B)

Le présent appareil est conforme aux CNR d'Industrie Canada applicables aux appareils radio exempts. L'exploitation est autorisée aux deux conditions suivantes:

- l'appareil ne doit pas produire de brouillage, et
- l'utilisateur de l'appareil doit accepter tout brouillage radioélectrique subi, même si le brouillage est susceptible d'en compromettre le fonctionnement.

RF Exposure Warning

This equipment must be installed and operated in accordance with provide instructions and the antenna used for this transmitter must be installed to provide a separation distance of at least 20 cm from all persons and must not be co-located or operation in conjunction with any other antenna or transmitter. End-users and installers must be provided with antenna installation instructions and transmitter operating conditions for satisfying RF exposure compliance.

For product compliance test FCC and IC, all the technical documentation is submitted by MSA Safety, who is the customer or importer of the ProtoAir.

ProtoAir radios have been approved to be used with antennas that have a maximum gain of 3 dBi. Any antennas with a gain greater than 3 dBi are strictly prohibited for use with this device.

Power Output

Frequency Range Output Power:

Wi-Fi

2402.0 – 2480 MHz 0.004 W

2412.0 – 2462.0 MHz 0.0258 W

The Output Power listed is conducted. The device should be professionally installed to ensure compliance with power requirements. The antenna(s) used for this transmitter must be installed to provide a separation distance of at least 20 cm from all persons and not be co-located with any other transmitters except in accordance with multi-transmitter product procedures. This device supports 20MHz and 40MHz bandwidth.

