

Benchmark[®] Boilers with Edge[®] [ii] Controller

Natural Gas, Propane Gas and Dual Fuel
Modulating & Condensing Boilers

Models 750 through 6000

Other documents for this product include:

- OMM-0136, GF-210 210 Installation and Startup Manual
- OMM-0138, GF-212 Reference Manual
- OMM-0139, GF-213 Edge Controller Manual
- TAG-0019, GF-2070 Boiler Application Guide
- TAG-0022, GF-2050 Vent-Combustion Air Guide
- TAG-0047, GF-2030 Benchmark Gas Guide
- TAG-0048, GF-2060 Benchmark Power Guide

Applies to serial numbers:

- G-20-1800 and above – BMK750 – 5000N
- N-20-0125 and above – BMK5000 & 6000



Disclaimer

The information contained in this manual is subject to change without notice from AERCO International, Inc. AERCO makes no warranty of any kind with respect to this material, including, but not limited to, implied warranties of merchantability and fitness for a particular application. Some states do not allow the exclusion or limitation of incidental or consequential damages, so the above limitation may not apply. AERCO is not liable for errors appearing in this manual, not for incidental or consequential damages occurring in connection with the furnishing, performance, or use of these materials.



IMPORTANT

Read this Manual BEFORE using this equipment. Failure to read and follow all safety and use information can result in death, serious personal injury, property damage, or damage to the equipment.

Keep this Manual for future reference.

Table of Contents

FOREWORD6

SECTION 1: SAFETY PRECAUTIONS9

1.1 WARNINGS & CAUTIONS9

1.2 EMERGENCY SHUTDOWN10

1.3 PROLONGED SHUTDOWN10

1.4 IMPORTANT – FOR MASSACHUSETTS INSTALLATIONS11

SECTION 2: EDGE CONTROLLER OPERATION13

2.1 INTRODUCTION13

2.2 LOGIN AND PASSWORD ENTRY14

SECTION 3: START SEQUENCE15

3.1 INTRODUCTION15

3.2 START SEQUENCE15

3.3 START/STOP LEVELS23

3.4 START/STOP LEVELS – AIR/FUEL & ENERGY INPUT24

 3.4.1 BMK750/1000 Air/Fuel Valve Position and Energy Input24

 3.4.2 BMK1500 Air/Fuel Valve Position and Energy Input25

 3.4.3 BMK2000 Air/Fuel Valve Position and Energy Input27

 3.4.4 BMK2500 Air/Fuel Valve Position and Energy Input28

 3.4.5 BMK3000 Air/Fuel Valve Position and Energy Input29

 3.4.6 BMK4000 Air/Fuel Valve Position and Energy Input30

 3.4.7 BMK5000N Air/Fuel Valve Position and Energy Input31

 3.4.8 Benchmark 5000 Air/Fuel Valve Position and Energy Input32

 3.4.9 Benchmark 6000 Air/Fuel Valve Position and Energy Input33

SECTION 4: INITIAL START-UP34

4.1 INITIAL START-UP REQUIREMENTS34

4.2 TOOLS & INSTRUMENTS FOR COMBUSTION CALIBRATION35

 4.2.1 Required Tools & Instrumentation35

 4.2.2 Installing Gas Supply Manometer35

 4.2.3 Accessing the Analyzer Probe Port39

4.3 BENCHMARK 5000 & 6000 PILOT FLAME IGNITION40

4.4 FUEL TYPES AND COMBUSTION CALIBRATION40

4.5 COMBUSTION CALIBRATION40

 4.5.1 NATURAL GAS Manual Combustion Calibration41

 4.5.2 PROPANE GAS COMBUSTION CALIBRATION47

4.6 REASSEMBLY 52

4.7 DUAL FUEL SWITCHOVER52

4.8 OVER-TEMPERATURE LIMIT SWITCHES53

 4.8.1 Adjusting the Automatic Reset Limit Switch Temperature53

 4.8.2 Resetting the Manual Reset Limit Switch54

 4.8.3 Changing the Readout Between Fahrenheit and Celsius54

SECTION 5: SAFETY DEVICE TESTING55

5.1 TESTING OF SAFETY DEVICES55

5.2 LOW GAS PRESSURE TEST55

 5.2.1 LOW GAS PRESSURE TEST: BMK750 – 250055

CONTENTS

5.2.2 LOW GAS PRESSURE TEST: BMK3000 – 6000 Only	58
5.3 HIGH GAS PRESSURE TEST	60
5.3.1 HIGH GAS PRESSURE TEST: BMK750 – 2500	60
5.3.2 HIGH GAS PRESSURE TEST: BMK3000 – 6000 Only	63
5.4 LOW WATER LEVEL FAULT TEST	67
5.5 WATER TEMPERATURE FAULT TEST	68
5.6 INTERLOCK TESTS.....	69
5.6.1 Remote Interlock Test.....	69
5.6.2 Delayed Interlock Test	69
5.7 FLAME FAULT TEST	70
5.8 AIR FLOW FAULT TESTS-BLOWER PROOF & BLOCKED INLET SWITCHES	71
5.8.1 Blower Proof Switch Test.....	71
5.8.2 Blocked Inlet Switch Test.....	73
5.9 SSOV PROOF OF CLOSURE SWITCH CHECK.....	74
5.10 PURGE SWITCH OPEN DURING PURGE.....	75
5.11 IGNITION SWITCH OPEN DURING IGNITION	77
5.12 SAFETY PRESSURE RELIEF VALVE TEST.....	77
SECTION 6: STANDALONE MODES OF OPERATION	78
6.1 OUTDOOR RESET MODE	78
6.1.1 Outdoor Air Temperature Sensor Installation	78
6.1.2 Outdoor Reset Mode Startup	79
6.2 CONSTANT SETPOINT MODE	80
6.3 REMOTE SETPOINT MODE	80
6.4 DIRECT DRIVE MODES.....	81
6.5 AERCO CONTROL SYSTEM (ACS)	81
6.6 COMBINATION CONTROL SYSTEM (CCS)	82
6.6.1 Combination Control System Field Wiring.....	83
6.6.2 Combination Control System Setup and Startup.....	83
SECTION 7: BOILER SEQUENCING TECHNOLOGY	84
7.1 INTRODUCTION.....	84
7.1.1 Installation Notes.....	85
7.2 BST IMPLEMENTATION INSTRUCTION	85
7.2.1 BST Setup: Constant Setpoint	87
7.2.2 BST Setup: Remote Setpoint.....	88
7.2.3 BST Setup: Outdoor Air Temperature Reset.....	89
SECTION 8: MAINTENANCE	90
8.1 MAINTENANCE SCHEDULE.....	90
8.2 BENCHMARK 750-5000N IGNITER-INJECTOR	91
8.2.1 Pilot Ignition – Benchmark 5000-6000	92
8.3 FLAME DETECTOR	93
8.4 O ₂ SENSOR (IF EQUIPPED).....	93
8.4.1 Air Eductor Air Pump Maintenance – BMK5000 & 6000	95
8.5 SAFETY DEVICE TESTING	95
8.6 BURNER INSPECTION	95
8.7 CONDENSATE DRAIN TRAP	98
8.8 AIR FILTER CLEANING AND REPLACEMENT.....	98

CONTENTS

8.9 WATER QUALITY	98
8.10 REFRACTORY REPLACEMENT – BMK5000 & 6000 ONLY	99
8.11 SHUTTING BOILER DOWN FOR EXTENDED PERIOD	100
8.11.1 Benchmark 5000 & 6000 Long Term Blower Storage	100
8.12 RETURNING THE BOILER TO SERVICE AFTER SHUTDOWN.....	101
8.13 RECOMMENDED PERIODIC TESTING	102
8.14 RECOMMENDED SPARES	103
SECTION 9: AERTRIM OPERATION.....	104
9.1 AERTRIM INTRODUCTION.....	104
9.2 AERTRIM ACTIVATION	105
9.3 OPERATION DETAILS.....	105
9.4 O ₂ SENSOR CALIBRATION.....	106
9.5 AERTRIM MENU VALUES AND DEFAULTS.....	107
9.6 AERTRIM MAINTENANCE AND TROUBLESHOOTING	118
SECTION 10: TROUBLESHOOTING	119
10.1 INTRODUCTION.....	119
10.2 ADDITIONAL FAULTS WITHOUT SPECIFIC FAULT MESSAGES	127
SECTION 11: WIRING DIAGRAMS	128
11.1 BENCHMARK 750 – 2000 SCHEMATICS	128
11.2 BENCHMARK 2500 – 3000 SCHEMATICS	132
11.3 BENCHMARK 4000 – 5000N SCHEMATICS.....	138
11.4 BENCHMARK 5000 – 6000 SCHEMATICS	146

FOREWORD

The AERCO Benchmark (BMK) 750 through 6000 natural gas and propane fueled boilers are modulating and condensing units. They represent a true industry advance that meets the needs of today's energy and environmental concerns. Designed for application in any closed loop hydronic system, the Benchmark's modulating capability relates energy input directly to fluctuating system loads. These BMK models provide extremely high efficiency operation and are ideally suited for modern low temperatures, as well as conventional heating systems.

IMPORTANT!

- All descriptions provided in this document apply to the Benchmark Series of boilers.
- All measurements apply to both natural gas and propane models, unless otherwise specified.

The Benchmark models operate within the following input and output ranges:

Benchmark Boiler Intake and Output Ranges				
MODEL	INPUT RANGE (BTU/HR.)		OUTPUT RANGE (BTU/HR.)	
	MINIMUM	MAXIMUM	MINIMUM	MAXIMUM
BMK750	50,000 (14.6 kW)	750,000 (220 kW)	47,750 (14 kW)	716,250 (210 kW)
BMK1000	50,000 (14.6 kW)	1,000,000 (293 kW)	48,300 (14.15 kW)	968,000 (284 kW)
BMK1500	75,000 (22 kW)	1,500,000 (440 kW)	64,500 (18.9 kW)	1,395,000 (409 kW)
BMK2000	100,000 (29.3 kW)	2,000,000 (586 kW)	86,000 (25.2 kW)	1,860,000 (545 kW)
BMK2500	167,000 (48.9 kW)	2,500,000 (732 kW)	144,000 (42.2 kW)	2,395,000 (702 kW)
BMK3000	200,000 (58.6 kW)	3,000,000 (879 kW)	174,000 (51.0 kW)	2,874,000 (842 kW)
BMK4000	267,000 (78.2 kW)	4,000,000 (1172 kW)	232,000 (68.0 kW)	3,800,000 (1113 kW)
BMK5000N	250,000 (73.3 kW)	4,990,000 (1462 kW)	218,000 (63.9 kW)	4,740,000 (1389 Kw)
BMK5000	400,000 (117 kW)	5,000,000 (1465 kW)	348,000 (102 kW)	4,750,000 (1392 kW)
BMK6000	400,000 (117 kW)	6,000,000 (1758 kW)	348,000 (102 kW)	5,700,000 (1670 kW)

The output of the boiler is a function of the unit's firing rate (valve position) and return water temperature.

When installed and operated in accordance with this Instruction Manual, the BMK750 – 2000 and 5000 & 6000 comply with the NOx emission standards outlined in: **South Coast Air Quality Management District (SCAQMD), Rule 1146.2**. In addition, the BMK2500 – 6000 complies with the **Bay Area Air Quality Management District regulation 9, Rule 7**.

Whether in singular or modular arrangements, BMK boilers offer maximum venting flexibility with minimum installation space requirements. These boilers are Category II and IV, positive pressure appliances. Single and/or multiple breeched units can operate in the following vent configurations:

- Room Combustion Air:
 - Vertical Discharge
 - Horizontal Discharge
- Ducted Combustion Air:
 - Vertical Discharge
 - Horizontal Discharge

These boilers are capable of being vented utilizing Polypropylene and AL29-4C vent systems. In addition, the BMK750 & 1000 models are also approved for PVC and CPVC, vent systems (excluding the state of Massachusetts).

Benchmark's advanced electronics are available in several selectable modes of operation offering the most efficient operating methods and energy management system integration.

AERCO Technical Terminology Meanings	
TERMINOLOGY	MEANING
A (Amp)	Ampere
ACS	AERCO Control System, AERCO’s boiler management systems
ADDR	Address
AGND	Analog Ground
ALRM	Alarm
ANSI	American National Standards Institute,
ASME	American Society of Mechanical Engineers
AUX	Auxiliary
BAS	Building Automation System, often used interchangeably with EMS (see below)
Baud Rate	Symbol rate, or the number of distinct symbol changes (signaling events) transmitted per second. NOT equal to bits per second unless each symbol is 1 bit.
BMK (Benchmark)	AERCO’s Benchmark series boilers
BMS or BMS II	AERCO Boiler Management Systems
BLDG (Bldg)	Building
BST	AERCO on-board Boiler Sequencing Technology
BTU	British Thermal Unit. A unit of energy approximately equal to the heat required to raise 1 pound (0.45 kg) of water 1°F (0.55 °C)
BTU/HR	BTUs per Hour (1 BTU/hr = 0.29 W)
CCS	Combination Control System
CFH	Cubic Feet per Hour (1 CFH = 0.028 m3/hr)
CO	Carbon Monoxide
COMM (Comm)	Communication
Cal.	Calibration
CNTL	Control
CPU	Central Processing Unit
DBB	Double Block and Bleed, a gas train containing 2 Safety Shutoff Valves (SSOVs) and a solenoid operated vent valve.
DIP	Dual In-Line Package, a type of switch
ECU	Electronic Control Unit (O2 sensor)
Edge Controller	A control system developed by AERCO used in all Benchmark boilers.
EMS	Energy Management System; often used interchangeably with BAS
FM	Factory Mutual. Used to define boiler gas trains.
GF-xxxx	Gas Fired (an AERCO document numbering system)
GND	Ground
HDR	Header
Hex	Hexadecimal Number (0 – 9, A – F)
HP	Horsepower
HX	Heat Exchanger
Hz	Hertz (Cycles Per Second)
I.D.	Inside Diameter
IGN	Ignition
IGST Board	Ignition/Stepper Board, contained in Edge Controller
INTLK (INTL’K)	Interlock
I/O	Input/Output
I/O Box	Input/Output (I/O) Box currently used on Benchmark boilers

AERCO Technical Terminology Meanings	
TERMINOLOGY	MEANING
IP	Internet Protocol
ISO	International Organization for Standardization
Lbs.	Pounds (1 lb. = 0.45 kg)
LED	Light Emitting Diode
LN	Low Nitrogen Oxide
MA (mA)	Milliampere (0.001)
MAX (Max)	Maximum
MBH	1000 BTUs per Hour
MIN (Min)	Minimum
Modbus®	A serial, half-duplex data transmission protocol developed by AEG Modicon
NC (N.C.)	Normally Closed
NO (N.O.)	Normally Open
NOx	Nitrogen Oxide
NPT	National Pipe Thread
O.D.	Outside Diameter
OMM, O&M	Operation and Maintenance Manual
onAER	AERCO's on-line remote monitoring system
PCB	Printed Circuit Board
PMC Board	Primary Micro-Controller (PMC) board, contained in the Edge
POC	Proof of Closure
PPM	Parts per Million
PSI	Pounds per Square Inch (1 PSI = 6.89 kPa)
PTP	Point-to-Point (usually over RS232 networks)
P&T	Pressure and Temperature
ProtoNode	Hardware interface between BAS and a boiler or water heater
PWM	Pulse Width Modulation
RES.	Resistive
RS232 (or EIA-232)	A standard for serial, full-duplex data transmission based on the RS232 Standard
RS485 (or EIA-485)	A standard for serial, half-duplex data transmission based on the RS485 Standard
RTN (Rtn)	Return
SETPT (Setpt)	Setpoint Temperature
SHLD (Shld)	Shield
SPDT	Single Pole Double Throw, a type of switch
SSOV	Safety Shut Off Valve
Terminating Resistor	A resistor placed at each end of a daisy-chain or multi-drop network to prevent reflections that may cause invalid data in the communication
Tip-N-Tell	A device that indicates if a package was tipped during shipping
UL	A business that tests and validates products
VAC	Volts, Alternating Current
VDC	Volts, Direct Current
VFD	Variable Frequency Drive
VPS	Valve Proving System
W	Watt
W.C.	Water Column, a unit of pressure (1 W.C. = 249 Pa)
µA	Micro amp (1 millionth of an ampere)

SECTION 1: SAFETY PRECAUTIONS**1.1 Warnings & Cautions**

Installers and operating personnel **MUST** observe all safety regulations. The following warnings and cautions are general and must be given the same attention as specific precautions included in these instructions. In addition to the requirements in this manual, installation **MUST** conform with local building codes, or, in the absence of local codes, ANSI Z223.1 (National Fuel Gas Code Publication No. NFPA-54) for gas-fired boilers and ANSI/NFPASB for LP gas-fired boilers. Where applicable, the equipment shall be installed in accordance with the current Installation Code for Gas Burning Appliances and Equipment, CSA B149.1, and applicable Provincial regulations for the class, which should be carefully followed in all cases. Authorities having jurisdiction should be consulted before installations are made.

IMPORTANT!

This manual is an integral part of the product and must be maintained in legible condition. It must be given to the user by the installer and kept in a safe place for future reference.

⚠ WARNING!

- Do not use matches, candles, flames, or other sources of ignition to check for gas leaks.
- Fluids under pressure may cause injury to personnel or damage to equipment when released. Be sure to shut off all incoming and outgoing water shutoff valves. Carefully decrease all trapped pressures to zero before performing maintenance.
- Before attempting to perform any maintenance on the unit, shut off all gas and electrical inputs to the unit.
- The exhaust vent pipe of the unit operates under a positive pressure and therefore must be completely sealed to prevent leakage of combustion products into living spaces.
- Electrical voltages up to **120 VAC (BMK750 – 2000), 208 or 480 VAC (BMK2500 – BMK3000), 480 VAC (BMK4000 & 5000N), or 208, 480 or 575 VAC (BMK5000 & 6000) and 24 volts AC** may be used in this equipment. Therefore, the cover on the unit's power box (located behind the front panel door) must be always installed, except during maintenance and servicing.
- A single-pole (120 VAC units) or three-pole (220 VAC and higher units) switch must be installed on the electrical supply line of the unit. The switch must be installed in an easily accessible position to quickly and safely disconnect electrical service. Do not affix switch to unit sheet metal enclosures.

CAUTION!

- Many soaps used for gas pipe leak testing are corrosive to metals. The piping must be rinsed thoroughly with clean water after leak checks have been completed.
- **DO NOT** use this boiler if any part has been under water. Call a qualified service technician to inspect and replace any part that has been under water.

1.2 Emergency Shutdown

If overheating occurs or the gas supply fails to shut off, close the manual shutoff valve (Figure 1-1) located external to the unit.

NOTE: Installer must identify location of emergency shutdown manual gas valve to operating personnel.



Figure 1-1: External Manual Gas Shutoff Valve

In addition, to ensure safety an emergency shutdown procedure that addresses the following points should be designed and implemented at the site:

- For automatically operated unattended boilers located in a boiler room, provide a manually operated remote shutdown switch or circuit breaker located just inside or outside each boiler room door. Design the system so activation of the emergency shutdown switch or circuit breaker will immediately shut off the fuel supply to the unit(s).
- For automatically operated unattended boilers in a location other than a boiler room, provide a manually operated remote shutdown switch or circuit breaker marked for easy identification at a location readily accessible in the event of boiler mis-operation.
- Design the system so activation of the emergency shutdown switch or circuit breaker will immediately shut off the fuel.
- For boilers monitored and/or operated from a continuously occupied control room, provide an emergency shutdown switch in the control room that is hard-wired to immediately shut off the fuel upon activation.

1.3 Prolonged Shutdown

In an emergency, turn off electrical power to the boiler and close the manual gas valve located upstream from the unit. The installer must identify the emergency shut-off device.

If the unit is being shut down for an extended period, such as a year or more, complete the instructions in Section 8.10: *Shutting Boiler Down for Extended Period*.

When returning a unit to service after a prolonged shutdown, it is recommended that the instructions in Section 4: *Initial Startup Procedures* and Section 5: *Safety Device Testing* be performed to verify that all system-operating parameters are correct.

1.4 IMPORTANT – Requirements for Massachusetts Installations

Boiler Installations within the Commonwealth of Massachusetts must conform to the following requirements:

- The boiler must be installed by a plumber or a gas fitter who is licensed within the Commonwealth of Massachusetts.
- Prior to unit operation, the complete gas train and all connections must be leak tested using a non-corrosive soap.
- The vent termination must be located a minimum of 4 feet above grade level. If side-wall venting is used, the installation must conform to the following requirements **extracted from 248 CMR 5.08 (2)**:

(a) For all side wall horizontally vented gas fueled equipment installed in every dwelling, building or structure used in whole or in part for residential purposes, including those owned or operated by the Commonwealth and where the side wall exhaust vent termination is less than seven (7) feet above finished grade in the area of the venting, including but not limited to decks and porches, the following requirements shall be satisfied:

1. INSTALLATION OF CARBON MONOXIDE DETECTORS: At the time of installation of the side wall horizontal vented gas fueled equipment, the installing plumber or gasfitter shall observe that a hard-wired carbon monoxide detector with an alarm and battery back-up is installed on the floor level where the gas equipment is to be installed. In addition, the installing plumber or gasfitter shall observe that a battery operated or hard-wired carbon monoxide detector with an alarm is installed on each additional level of the dwelling, building or structure served by the side wall horizontal vented gas fueled equipment. It shall be the responsibility of the property owner to secure the services of qualified licensed professionals for the installation of hard-wired carbon monoxide detectors.

a. If the side wall horizontally vented gas fueled equipment is installed in a crawl space or an attic, the hard-wired carbon monoxide detector with alarm and battery back-up may be installed on the next adjacent floor level.

b. In the event that the requirements of this subdivision cannot be met at the time of completion of installation, the owner shall have a period of thirty (30) days to comply with the above requirements; provided, however, that during said thirty (30) day period, a battery-operated carbon monoxide detector with an alarm shall be installed.

2. APPROVED CARBON MONOXIDE DETECTORS: *Each carbon monoxide detector as required in accordance with the above provisions shall comply with NFPA 720 and be ANSI/UL 2034 listed and IAS certified.*

3. SIGNAGE: A metal or plastic identification plate shall be permanently mounted to the exterior of the building at a minimum height of eight (8) feet above grade directly in line with the exhaust vent terminal for the horizontally vented gas fueled heating appliance or equipment. The sign shall read, in print size no less than one-half (1/2) inch in size, "**GAS VENT DIRECTLY BELOW. KEEP CLEAR OF ALL OBSTRUCTIONS**". (Continued)

4. INSPECTION: The state or local gas inspector of the side wall horizontally vented gas

SECTION 1: SAFETY PRECAUTIONS

fueled equipment shall not approve the installation unless, upon inspection, the inspector observes carbon monoxide detectors and signage installed in accordance with the provisions of 248 CMR 5.08(2)(a)1 through 4.

(b) EXEMPTIONS: The following equipment is exempt from 248 CMR 5.08(2)(a)1 through 4:

1. The equipment listed in Section 10 entitled "Equipment Not Required to Be Vented" in the most current edition of NFPA 54 as adopted by the Board; and
2. Product Approved side wall horizontally vented gas fueled equipment installed in a room or structure separate from the dwelling, building or structure used in whole or in part for residential purposes.

(c) MANUFACTURER REQUIREMENTS - GAS EQUIPMENT VENTING SYSTEM PROVIDED. When the manufacturer of Product Approved side wall horizontally vented gas equipment provides a venting system design or venting system components with the equipment, the instructions provided by the manufacturer for installation of the equipment and the venting system shall include:

1. Detailed instructions for the installation of the venting system design or the venting system components; and
2. A complete parts list for the venting system design or venting system.

(d) MANUFACTURER REQUIREMENTS - GAS EQUIPMENT VENTING SYSTEM NOT PROVIDED. When the manufacturer of a Product Approved side wall horizontally vented gas fueled equipment does not provide the parts for venting the flue gases, but identifies "special venting systems", the following requirements shall be satisfied by the manufacturer:

1. The referenced "special venting system" instructions shall be included with the appliance or equipment installation instructions; and
2. The "special venting systems" shall be Product Approved by the Board, and the instructions for that system shall include a parts list and detailed installation instructions.

(e) A copy of all installation instructions for all Product Approved side wall horizontally vented gas fueled equipment, all venting instructions, all parts lists for venting instructions, and/or all venting design instructions shall remain with the appliance or equipment at the completion of the installation.

..... **[End of Extracted Information From 248 CMR 5.08 (2)]**

SECTION 2: EDGE CONTROLLER OPERATION

2.1 Introduction

This section provides a brief outline of how to gain access to Benchmark Boiler’s Edge Controller functionality. Full instructions for using the Edge Controller to set up, configure and operate a Benchmark Boiler are included in the *Edge Controller Manual*.

NOTE: The *Edge Controller Manual* is document number OMM-0139.

The Edge Controller is shown below. This panel contains all the controls, indicators and displays necessary to operate, adjust and troubleshoot the boiler.

The Edge Controller’s front panel consists of a touchscreen display along with a variety of indicators and buttons.

1	Multi-Function Bar, shows either: <ul style="list-style-type: none"> • Fire Rate • Valve Position
2	Parameter Indicator for both temperature read-outs: <ul style="list-style-type: none"> • LEFT: Inlet or Setpoint temperature • RIGHT: Outlet or System Header temperature
3	Temperature scale indicator: Fahrenheit or Celsius
4	Configurable temperature read-outs (2): <ul style="list-style-type: none"> • LEFT: Inlet or Setpoint temperature • RIGHT: Outlet or System Header temperature
5	Operation Mode Indicators (2): <ul style="list-style-type: none"> • LEFT: Demand or Manual • RIGHT: Manager or Client (BST only)
6	Edge Controller Touchscreen
7	Soft Keys
8	onAER Indicator Light
9	Ready Light
10	Enable/Disable Switch
11	Low Water Level Buttons (2): <ul style="list-style-type: none"> • TEST: Initiates Low Water test • RESET: Resets unit after Low Water test

Figure 2-1 Edge Controller Front Panel

2.2 Login and Password Entry

The Edge Controller has multiple levels of password protection.

Level	Password	Description
1	No password	The default. Many parameters are visible but “Read Only.”
2	159	Allows routine maintenance to be performed. Appropriate for AERCO Trained technicians (ATT).

A higher-level password is reserved for AERCO Master Technicians (AMT). It is distributed on an individual basis. To enter a password:

1. On the Edge Controller, go to **Main Menu → Advanced Setup → Access**. The **Enter Password** screen appears.
2. Use the number keypad to enter the password (each number appears as a *), then press **Save**. You will have access to the functionality associated with the level of the password entered.



Figure 2.2: Enter Password Screen

3. Once you have successfully logged into the system, the **Main Menu** appears. All Edge functionality is accessed through one of the six **Main Menu** items.

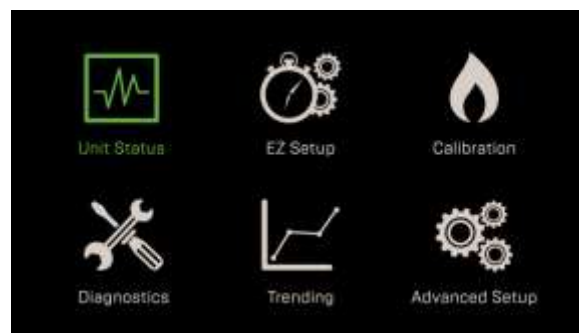

Figure 2-3: Edge Controller Main Menu

NOTE: Full instructions for using the Edge Controller are in the *Edge Controller Manual* (OMM-0139).

SECTION 3: START SEQUENCE

3.1 Introduction

The information in this section provides a guide to starting the Benchmark Boiler using the Edge Controller. It is imperative that the initial startup of this unit be performed by factory trained personnel. Operation prior to initial startup by factory trained personnel may void the equipment warranty. In addition, the following WARNINGS and CAUTIONS must always be observed.

⚠ WARNING!

- All of the installation procedures in the Benchmark Edge INSTALLATION Manual (OMM-136) must be completed before the initial start-up of the unit.
- Electrical voltages up to 120 VAC (BMK750 – 2000) and 208 or 460 VAC (BMK2500 – 5000N) or 208, 460 or 575 VAC (BMK5000 & 6000) and 24 volts AC may be used in this equipment. It must be serviced only by factory certified service technicians.
- Do not attempt to dry fire the unit. Starting the unit without a full water level can seriously damage the unit and may result in injury to personnel or property damage. This situation will void any warranty.
- Initial startup of the unit must be performed by AERCO factory trained personnel. Operation prior to initial startup by factory trained personnel may void the equipment warranty. In addition, the following WARNINGS and CAUTIONS must be observed at all times.

3.2 Start Sequence

When the Edge Controller Enable/Disable switch is set to the **Enable** position, it checks all pre-purge safety switches to ensure they are closed. These switches include:

- High Water Temperature switch
- High Gas Pressure switch
- Low Gas Pressure switch
- Low Water Level switch
- Safety Shut-Off Valve (SSOV) Proof of Closure (POC) switch

NOTE: The **Blocked Inlet** and downstream **Blower Proof** switches are **not** checked prior to starting the pre-purge.

If all of the above switches are closed, the READY light (above the Enable/Disable switch) will light when the switch is in the **Enable** position and the unit will be in the STANDBY mode.

NOTE: If any of the Pre-Purge safety device switches are open, or the required conditions are not observed throughout the start sequence, appropriate fault messages will be displayed.

When there is a demand for heat, the following events occur:

1. The Controller's red **DEMAND** LED status indicator will light.
2. The unit checks all five pre-purge safety switches listed at the beginning of this section. The Edge Controller's ignition sequence screen walks you through the ignition screens and demonstrates (or highlights) which switches are not met. SSOV locations are shown in Figure 3-1a through 3-1d.

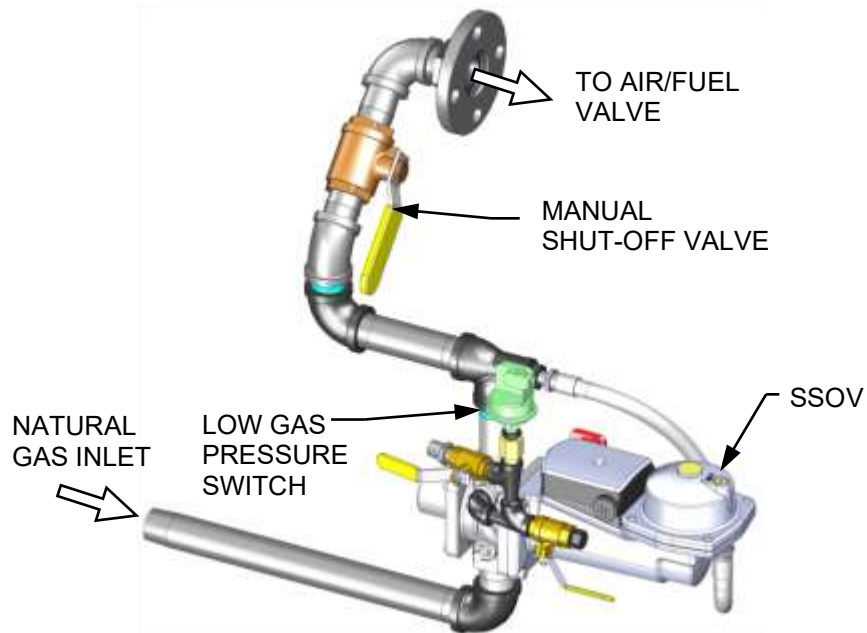

Figure 3-1a: BMK750 & 1000 SSOV Location (P/N 22322 shown)

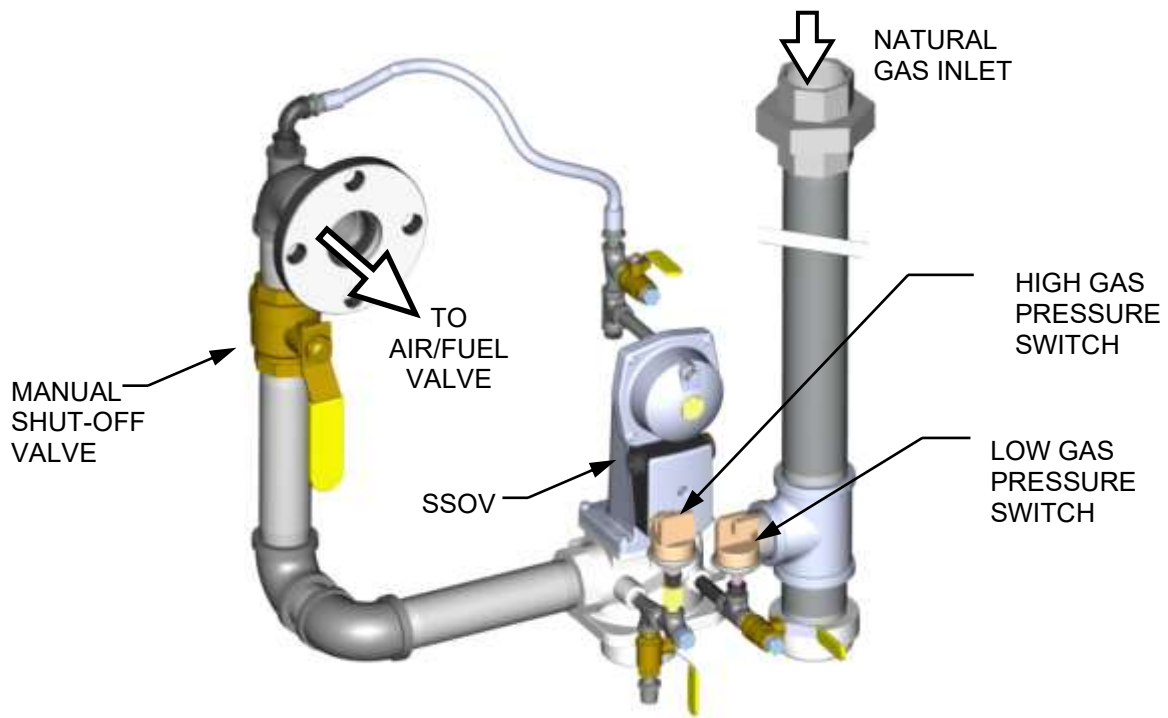

Figure 3-1b: BMK1500 & 2000 SSOV Location (P/N 22314 shown)

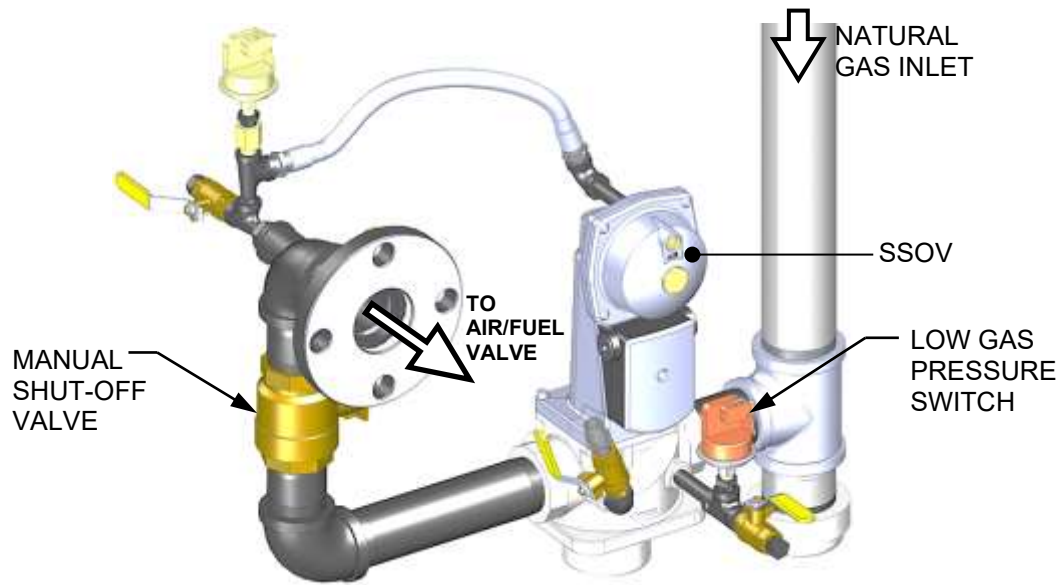

Figure 3-1c: BMK2500: SSOV Location (P/N 22318 shown)

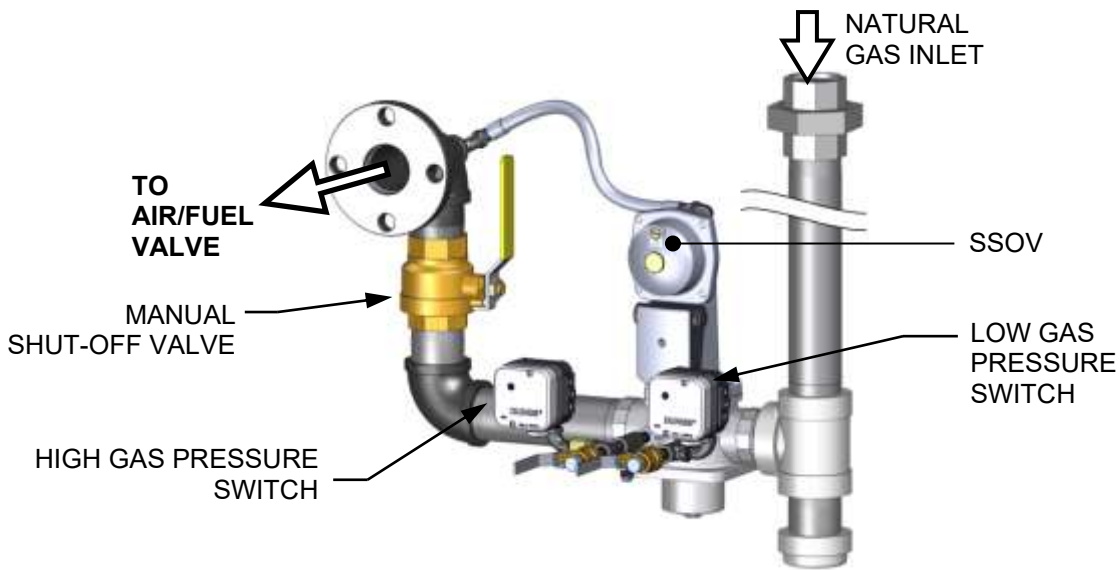

Figure 3-1d: BMK3000/4000/5000N: SSOV Location (P/N 22310 shown)

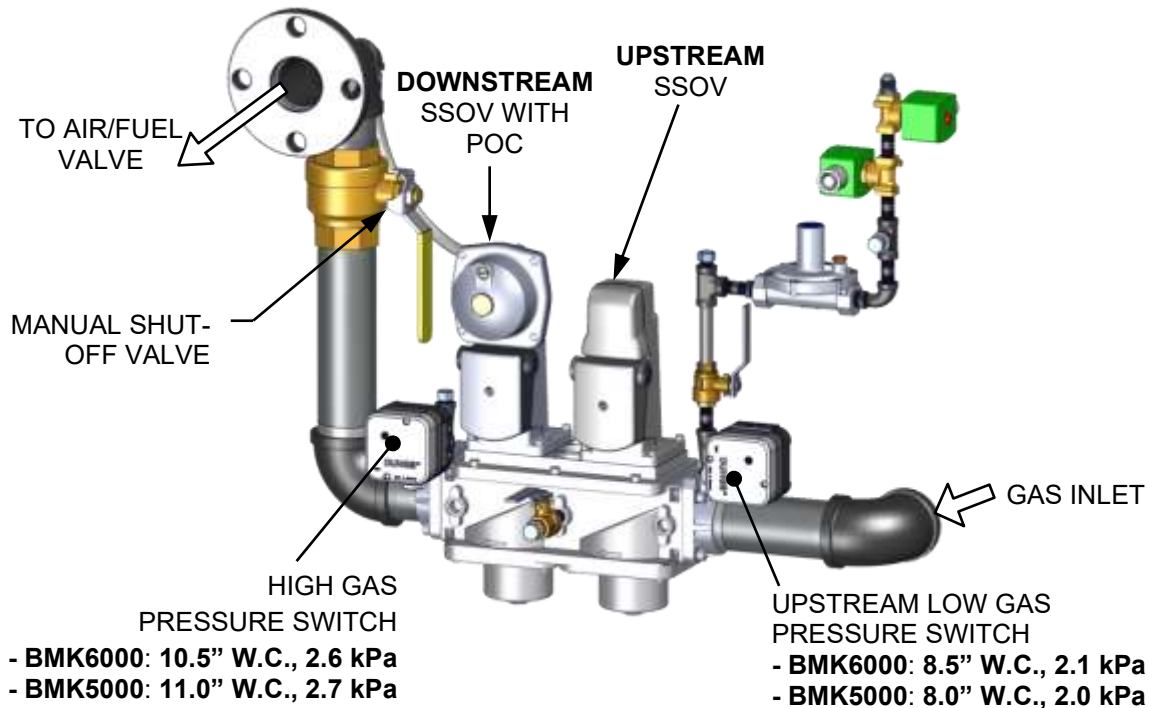

Figure 3-1e: BMK5000-6000: SSOV Location – BMK6000 Shown

3. The Auxiliary Delay occurs for a configurable length of time and the Delayed Interlocks are closed.
4. Once all required safety device switches are closed, a purge cycle is initiated, and the following events occur:
 - a. The Blower relay energizes and turns on the blower.
 - b. The Air/Fuel Valve rotates to the full-open purge position and closes the purge position switch. The dial on the Air/Fuel Valve (Figure 3-2a and 3-2b) will read **100** to indicate that it is full-open (100%).
 - c. The **Fire Rate** bar graph on the Controller’s front face shows 100%.

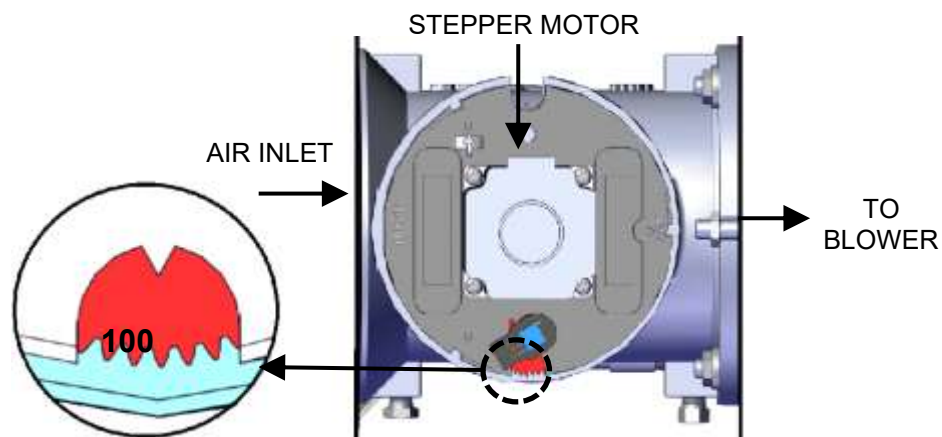

Figure 3-2a: BMK750 & 1000 Air/Fuel Valve in Purge Position

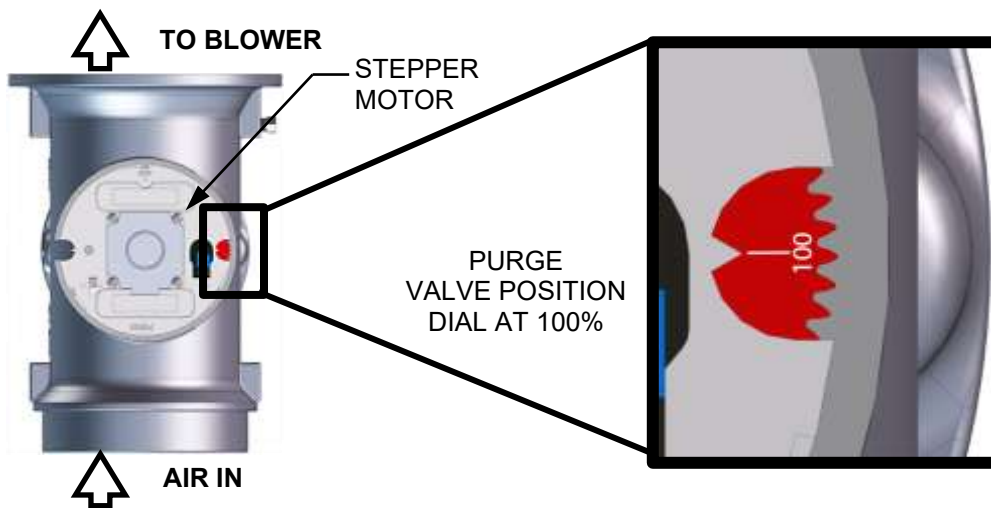

Figure 3-2b: BMK1500 – 6000 Air/Fuel Valve in Purge Position

- Next, the Blower Proof and Blocked Inlet switches close (Figure 3-4a and 3-4b). On the Ignition Sequence screen, the **Purging** indicator turns grey while purging is underway (Figure 3-3), and **Purge Timer** displays the purge cycle's elapsed time in seconds.

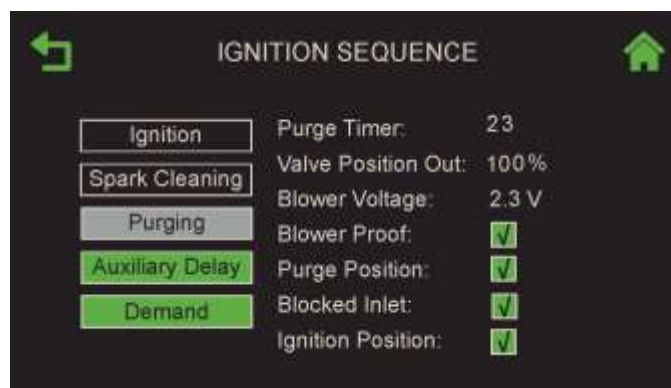

Figure 3-3: Ignition Sequence Screen – Purging

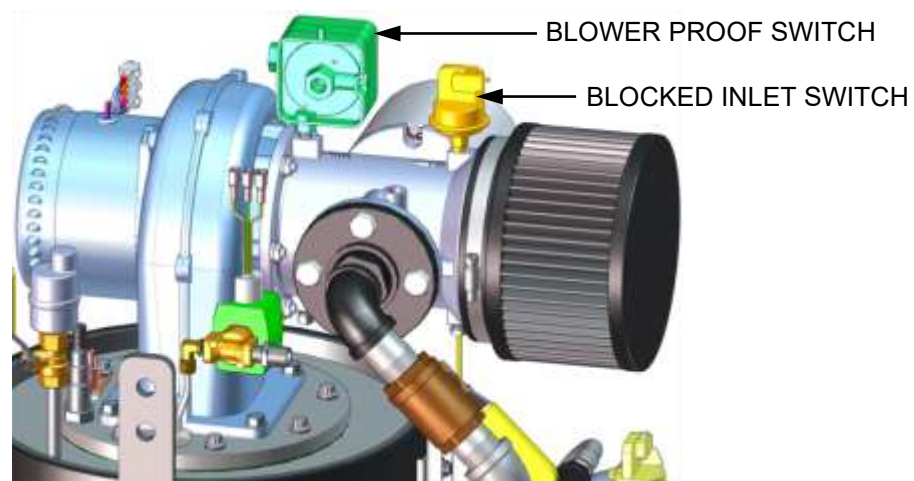

Figure 3-4a: BMK750 & 1000 Blower Proof Switch

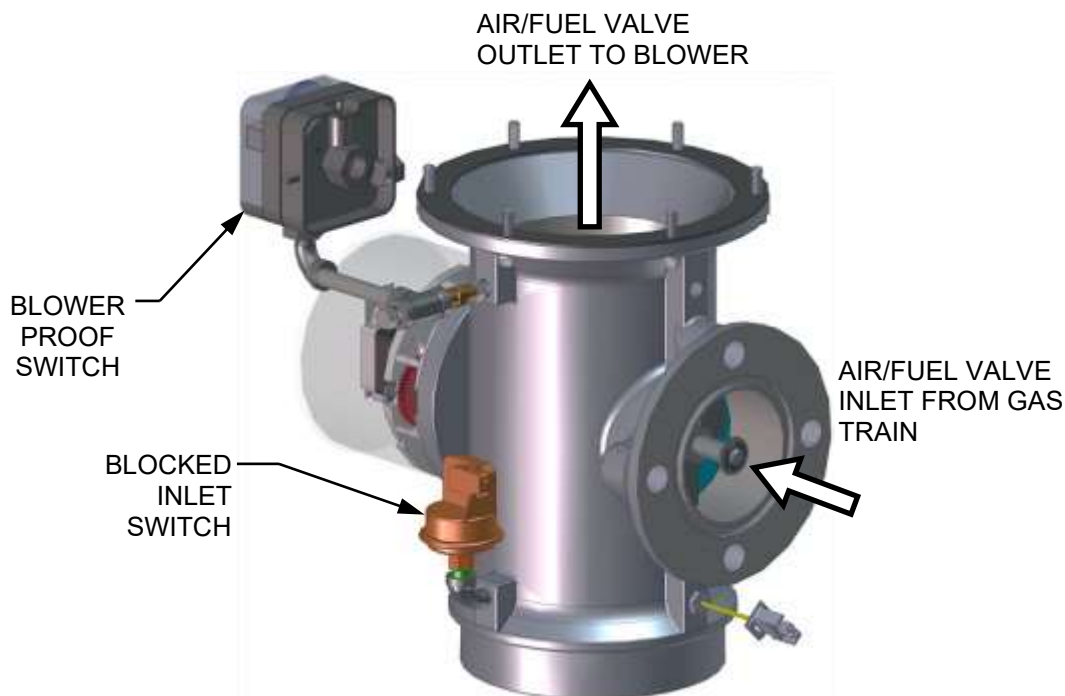

Figure 3-4b: BMK1500 – 6000 Blower Proof Switch

6. Upon completion of the purge cycle, the Controller initiates an ignition cycle, and the following events occur:
 - a) The Air/Fuel Valve rotates to the low-fire (Ignition) position and closes the ignition switch. The Dial on the Air/Fuel Valve (Figure 3-5) will read between **25** and **35** to indicate that the valve is in the low fire position.
 - b) The Spark Cleaning cycle begins (default duration = 7 sec.) and the Ignition Sequence screen's **Spark Cleaning** indicator (Figure 3-3) turns grey. This cycle turns on the ignition transformer to produce a spark (with no gas flowing) to remove moisture and carbon buildup from the spark element. For the duration of this cycle, the Controller displays the **Cleaning Igniter** status message.
 - c) Following the Spark Cleaning cycle, power is applied to the gas Safety Shut-off Valve (SSOV). When the SSOV indicates the Gas Valve is OPEN (POC) and the Ignition Sequence screen's **Ignition** indicator (Figure 3-3) turns grey.
 - d) If no spark is present 3 seconds into the ignition trial, the Controller aborts the Ignition Cycle and shuts down the boiler. Refer to Section 10: *Troubleshooting* in this guide for guidance if this occurs.

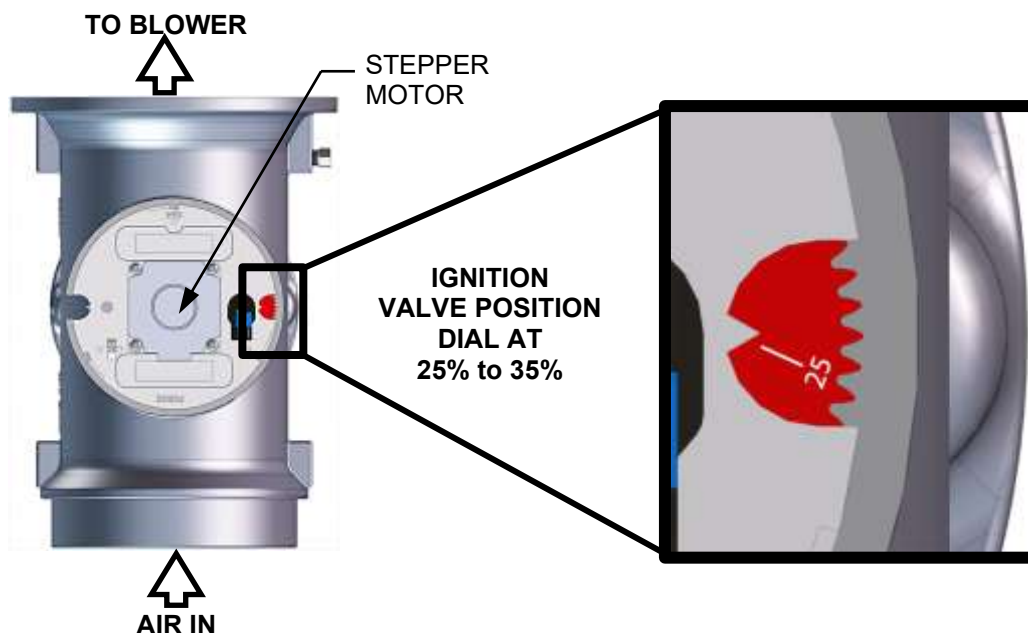

Figure 3-5: Air/Fuel Valve in Ignition Position

7. Up to 4 seconds are allowed for ignition to be detected. The ignition circuit is turned off one second after the flame is detected.
 8. After 2 seconds of continuous flame, the flame strength is indicated. After 5 seconds, the **Unit Status** screen appears.
 9. With the unit firing properly, it will be controlled by the temperature control circuitry. The boiler's fire rate or valve position (depending on which was chosen in Section 6.2.2: *Front Panel Configuration of the Edge Controller Manual*) will continuously display on the Controller's bar graph.
- Once the demand for heat has been satisfied, the Edge Controller will turn off the SSOV gas valve.

BMK5000 & 6000 Function Timing Chart for Proved Pilot Control System						
Component	Operating State					
	Standby	Pre-purge		PFEP	MFEP	Run
		T = 0	T = 30	T = 37	T = 44	
				PFEP	MFEP	
Edge Controller	Active	Active	Active	Active	Active	Active
Scanner Power	Active	Active	Active	Active	Active	Active
Ignition Power	Active	Active	Active	Active	Active	Active
SSOV Power	Active	Active	Active	Active	Active	Active
Pilot Valve Closed	Active	Active	Active	Active	Active	Active
Pilot Valve Open	Active	Active	Active	Active	Active	Active
Ignition Transformer Off	Active	Active	Active	Active	Active	Active
Ignition Transformer On	Active	Active	Active	Active	Active	Active
UV Scanner Powered	Active	Active	Active	Active	Active	Active
UV Scanner "Ignored"	Active	Active	Active	Active	Active	Active
UV Scanner in Use	Active	Active	Active	Active	Active	Active
Relay 1 Coil	Active	Active	Active	Active	Active	Active
Relay 1 C-NC	Active	Active	Active	Active	Active	Active
Relay 1 C-NO	Active	Active	Active	Active	Active	Active
Relay 2 Coil Power from R1	Active	Active	Active	Active	Active	Active
Relay 2 Coil Power from SKP 15 POC	Active	Active	Active	Active	Active	Active
Relay 2 C-NC	Active	Active	Active	Active	Active	Active
Relay 2 C-NO	Active	Active	Active	Active	Active	Active
SKP15 Power from R1 Contacts	Active	Active	Active	Active	Active	Active
SKP15 Power from R2 contact and POC C-NO	Active	Active	Active	Active	Active	Active
SKP15 Proof of Closure C-NC	Active	Active	Active	Active	Active	Active
SKP15 Proof of Closure C-NO	Active	Active	Active	Active	Active	Active
SKP25	Active	Active	Active	Active	Active	Active
Power through R1	Active	Active	Active	Active	Active	Active
Power through R2 and AUX	Active	Active	Active	Active	Active	Active
Proof of Closure C-NC	Active	Active	Active	Active	Active	Active
Proof of Closure C-NO	Active	Active	Active	Active	Active	Active

3.3 Start/Stop Levels

The start and stop levels are the Air/Fuel Valve positions (% open) that start and stop the unit, based on load. These levels are Factory preset as follows:

TABLE 3-1a: Start/Stop Levels – NATURAL GAS											
	BMK 750/1000	BMK 750/1000 DF	BMK 1500	BMK 2000	BMK 2500	BMK 3000	BMK 4000	BMK 5000N	BMK 4000 & 5000N DF	BMK 5000	BMK 6000
Start Level:	22%	24%	20%	24%	24%	20%	27%	24%	24%	24%	24%
Stop Level:	18%	18%	16%	18%	16%	14%	23%	18%	18%	18%	18%
Ignition Position	35%	30%	29%	29%	29%	29%	45%	40%	35%	35%	50%

TABLE 3-1b: Start/Stop Levels – PROPANE GAS										
	BMK 750/1000	BMK 750/1000 DF	BMK 1500	BMK 2000	BMK 2500	BMK 3000	BMK 4000	BMK 5000N	BMK 5000	BMK 6000
Start Level:	22%	24%	20%	24%	26%	22%	24%	24%	24%	24%
Stop Level:	18%	18%	16%	18%	18%	14%	18%	18%	18%	18%
Ignition Position	35%	30%	29%	29%	29%	29%	35%	35%	35%	50%

NOTE: These settings do not normally require adjustment.

NOTE: The energy input of the boiler is not linearly related to the Air/Fuel Valve position.

3.4 Start/Stop Levels – Air/Fuel & Energy Input

The Tables below show the relationship between the energy input and Air/Fuel Valve position for the BMK models covered in this document.

3.4.1 BMK750/1000 Air/Fuel Valve Position And Energy Input

TABLE 3-2a: BMK750/1000 Air/Fuel Valve Position – NATURAL GAS				
Air/Fuel Valve Position (% Open)	ENERGY INPUT (BTU/HR)		BOILER ENERGY INPUT (% OF FULL CAPACITY)	
	BMK750	BMK1000	BMK750	BMK1000
0%	0	0	0	0
10%	0	0	0	0
18% (Stop Level)	50,000 (14.7 kW)	50,000 (14.7 kW)	6.7%	5%
20%	52,000 (15.2 kW)	54,000 (15.8 kW)	6.9%	5.4%
30%	108,000 (31.7 kW)	140,000 (41.0 kW)	14%	14%
40%	246,000 (72.1 kW)	297,000 (87.0 kW)	33%	30%
50%	369,000 (108.1 kW)	443,000 (126.9 kW)	49%	44%
60%	465,000 (136.3 kW)	564,000 (165.3 kW)	62%	56%
70%	554,000 (162.4 kW)	660,000 (193.4 kW)	74%	66%
80%	637,000 (186.7 kW)	789,000 (231.2 kW)	85%	79%
90%	733,000 (214.8 kW)	933,000 (273.4 kW)	98%	93%
100%	750,000 (219.8 kW)	1,000,000 (293.1 kW)	100%	100%

TABLE 3-2b: BMK750/1000 Air/Fuel Valve Position – PROPANE GAS				
Air/Fuel Valve Position (% Open)	Energy Input (BTU/Hr)		Boiler Energy Input (% of Full Capacity)	
	BMK750	BMK1000	BMK750	BMK1000
0%	0	0	0	0
10%	0	0	0	0
18% (Stop Level)	50,000 (14.7 Kw)	50,000 (14.7 kW)	6.7%	5.0%
20%	71,000 (20.8 kW)	71,000 (20.8 kW)	9.5%	7.1%
30%	128,000 (37.5 kW)	181,000 (53.0 kW)	17%	18%
40%	373,000 (109.3 kW)	400,000 (117.2 kW)	50%	40%
50%	508,000 (148.9 kW)	562,000 (164.7 kW)	68%	56%
60%	565,000 (165.6 kW)	703,000 (206.0 kW)	75%	70%
70%	621,000 (182.0 kW)	791,000 (231.8 kW)	83%	79%
80%	660,000 (193.4 kW)	865,000 (253.5 kW)	88%	87%
90%	723,000 (211.9 kW)	963,000 (282.2 kW)	96%	96%
100%	750,000 (219.8 kW)	1,000,000 (293.1 kW)	100%	100%

SECTION 3 - START SEQUENCE

TABLE 3-2c: BMK750/1000 DUAL FUEL Air/Fuel Valve Position – NATURAL GAS				
Air/Fuel Valve Position (% Open)	Energy Input (BTU/Hr)		Boiler Energy Input (% of Full Capacity)	
	BMK750 Dual Fuel	BMK 1000 Dual Fuel	BMK750 Dual Fuel	BMK 1000 Dual Fuel
18% (Stop Level)	48,850 (14.3 Kw)	48,850 (14.3 Kw)	6.5%	4.9%
20%	62,000 (18.2 Kw)	62,000 (18.2 Kw)	8.3%	6.2%
30%	132,000 (38.7 Kw)	132,000 (38.7 Kw)	17.6%	13.2%
40%	239,000 (70.0 Kw)	239,000 (70.0 Kw)	31.9%	23.9%
50%	358,000 (104.9 Kw)	358,000 (104.9 Kw)	47.7%	35.8%
60%	488,300 (143.1 Kw)	488,300 (143.1 Kw)	65.1%	48.8%
70%	571,000 (167.3 Kw)	633,500 (185.7 Kw)	76.1%	63.4%
80%	633,500 (185.7 Kw)	756,000 (221.6 Kw)	84.5%	75.6%
90%	693,200 (203.2 Kw)	894,000 (262.0 Kw)	92.4%	89.4%
100%	750,000 (219.8 Kw)	1,000,000 (293.1 Kw)	100.0%	100.0%

TABLE 3-2d: BMK750/1000 DUAL FUEL Air/Fuel Valve Position – PROPANE GAS						
Air/Fuel Valve Position (% Open)	Energy Input (BTU/Hr)				Boiler Energy Input (% of Full Capacity)	
	BMK750 Dual Fuel		BMK 1000 Dual Fuel		BMK750 Dual Fuel	BMK 1000 Dual Fuel
18% (Stop Level)	48,850	(14.32 Kw)	48,850	(14.32 Kw)	7.1%	5.3%
20%	62,000	(18.2 Kw)	62,000	(18.2 Kw)	8.7%	6.5%
30%	132,000	(38.7 Kw)	132,000	(38.7 Kw)	16.7%	12.5%
40%	239,000	(70.0 Kw)	239,000	(70.0 Kw)	30.8%	23.1%
50%	358,000	(104.9 Kw)	358,000	(104.9 Kw)	44.9%	33.6%
60%	488,300	(143.1 Kw)	488,300	(143.1 Kw)	63.6%	47.7%
70%	571,000	(167.3 Kw)	633,500	(185.7 Kw)	72.7%	60.9%
80%	633,500	(185.7 Kw)	756,000	(221.6 Kw)	81.1%	71.0%
90%	693,200	(203.2 Kw)	894,000	(262.0 Kw)	85.7%	88.8%
100%	750,000	(219.8 Kw)	1,000,000	(293.1 Kw)	100.0%	100.0%

3.4.2 BMK1500 Air/Fuel Valve Position and Energy Input

TABLE 3-3a: BMK1500 Air/Fuel Valve Position – NATURAL GAS		
AIR/FUEL VALVE POSITION (% OPEN)	ENERGY INPUT (BTU/HR)	BOILER ENERGY INPUT (% OF FULL CAPACITY)
16% (Stop Level)	75,000 (22.3 kW)	5.0%
20%	127,000 (37.2 kW)	8.5%
30%	366,000 (107.2 kW)	24.4%
40%	629,000 (184.3 kW)	41.9%
50%	822,000 (240.9 kW)	54.7%
60%	977,000 (286.2 kW)	65.0%
70%	1,119,000 (327.9 kW)	74.5%
80%	1,255,000 (367.7 kW)	83.5%
90%	1,396,000 (409.0 kW)	92.9%
100%	1,502,000 (440.1 kW)	100%

TABLE 3-3b: BMK1500 Air/Fuel Valve Position – PROPANE GAS		
AIR/FUEL VALVE POSITION (% OPEN)	ENERGY INPUT (BTU/HR)	BOILER ENERGY INPUT (% OF FULL CAPACITY)
18% (Stop Level)	75,000 (21.9 kW)	5.0%
20%	93,700 (27.5 kW)	6.2%
30%	254,000 (74.4 kW)	16.9%
40%	505,000 (148.0 kW)	33.7%
50%	680,000 (199.3 kW)	45.3%
60%	807,000 (236.5 kW)	53.8%
70%	947,000 (277.5 kW)	63.1%
80%	1,157,000 (339.1 kW)	77.1%
90%	1,379,000 (404.1 kW)	91.9%
100%	1,503,000 (440.5 kW)	100%

3.4.3 BMK2000 Air/Fuel Valve Position and Energy Input

TABLE 3-4a: BMK2000 Air/Fuel Valve Position – NATURAL GAS		
AIR/FUEL VALVE POSITION (% OPEN)	ENERGY INPUT (BTU/HR)	BOILER ENERGY INPUT (% OF FULL CAPACITY)
18% (Stop Level)	100,000 (29.3 kW)	5.7%
20%	143,000 (41.9 kW)	11%
30%	388,000 (113.7 kW)	23%
40%	759,000 (222.4 kW)	37%
50%	1,069,000 (313.2 kW)	51%
60%	1,283,000 (375.9 kW)	61%
70%	1,476,000 (432.5 kW)	74%
80%	1,675,000 (490.1 kW)	83%
90%	1,833,000 (537.1 kW)	93%
100%	2,000,000 (586.0 kW)	100%

TABLE 3-4b: BMK2000 Air/Fuel Valve Position – PROPANE GAS		
AIR/FUEL VALVE POSITION (% OPEN)	ENERGY INPUT (BTU/HR)	BOILER ENERGY INPUT (% OF FULL CAPACITY)
18% (Stop Level)	100,000	5.0%
20%	126,600	6.3%
30%	363,000	18.2%
40%	677,000	33.9%
50%	898,000	44.9%
60%	1,070,000	53.5%
70%	1,242,000	62.1%
80%	1,523,000	76.2%
90%	1,845,000	92.3%
100%	2,000,000	100%

3.4.4 BMK2500 Air/Fuel Valve Position and Energy Input

TABLE 3-5a: BMK2500 Air/Fuel Valve Position – NATURAL GAS, Single Fuel		
AIR/FUEL VALVE POSITION (% OPEN)	ENERGY INPUT (BTU/HR)	BOILER ENERGY INPUT (% OF FULL CAPACITY)
16% (Stop Level)	167,000 (48.9 kW)	6.7%
30%	430,000 (126.0 kW)	17%
40%	770,000 (225.7 kW)	31%
50%	1,070,000 (313.6 kW)	43%
60%	1,440,000 (422.0 kW)	58%
70%	1,815,000 (531.9 kW)	73%
80%	2,030,000 (594.9 kW)	81%
90%	2,300,000 (674.1 kW)	92%
100%	2,500,000 (732.7 kW)	100%

TABLE 3-5b: BMK2500 Air/Fuel Valve Position – PROPANE GAS		
AIR/FUEL VALVE POSITION (% OPEN)	ENERGY INPUT (BTU/HR)	BOILER ENERGY INPUT (% OF FULL CAPACITY)
18% (Stop Level)	155,000	6.2%
30%	400,000	16%
40%	808,000	32%
50%	1,055,000	42%
60%	1,330,000	53%
70%	1,671,000	67%
80%	1,998,000	80%
90%	2,280,000	91%
100%	2,500,000	100%

3.4.5 BMK3000 Air/Fuel Valve Position and Energy Input

TABLE 3-6a: BMK3000 Air/Fuel Valve Position – NATURAL GAS		
AIR/FUEL VALVE POSITION (% OPEN)	ENERGY INPUT (BTU/HR.)	BOILER ENERGY INPUT (% OF FULL CAPACITY)
14% (Stop Level)	200,000 (58.6 kW)	6.7%
30%	520,000 (152 kW)	17%
40%	880,000 (258 kW)	29%
50%	1,270,000 (372 kW)	42%
60%	1,680,000 (492 kW)	56%
70%	2,100,000 (615 kW)	70%
80%	2,390,000 (700 kW)	80%
90%	2,650,000 (777 kW)	88%
100%	3,000,000 (879 kW)	100%

TABLE 3-6b: BMK3000 Air/Fuel Valve Position – PROPANE GAS		
AIR/FUEL VALVE POSITION (% OPEN)	ENERGY INPUT (BTU/HR)	BOILER ENERGY INPUT (% OF FULL CAPACITY)
18% (Stop Level)	200,000	6.7%
30%	520,000	17%
40%	920,000	31%
50%	1,270,000	42%
60%	1,570,000	52%
70%	1,960,000	65%
80%	2,330,000	78%
90%	2,700,000	90%
100%	3,000,000	100%

3.4.6 BMK4000 Air/Fuel Valve Position and Energy Input

TABLE 3-7a: BMK4000 Air/Fuel Valve Position – NATURAL GAS		
AIR/FUEL VALVE POSITION (% OPEN)	ENERGY INPUT (BTU/HR.)	BOILER ENERGY INPUT (% OF FULL CAPACITY)
23% (Stop Level)	228,180	5.7%
30%	456,900	11.4%
40%	822,800	20.6%
50%	1,205,000	30.1%
60%	1,684,000	42.1%
70%	2,388,000	59.7%
80%	3,107,000	77.7%
90%	3,582,000	89.6%
100%	4,000,000	100%

TABLE 3-7b: BMK4000 Air/Fuel Valve Position – NATURAL GAS - DUAL FUEL		
AIR/FUEL VALVE POSITION (% OPEN)	ENERGY INPUT (BTU/HR.)	BOILER ENERGY INPUT (% OF FULL CAPACITY)
18% (Stop Level)	246,000	6.2%
20%	346,000	8.7%
30%	846,000	21%
40%	1,384,000	35%
50%	1,883,000	47%
60%	2,442,000	61%
70%	2,783,000	70%
80%	3,151,000	79%
90%	3,541,000	89%
100%	4,000,000	100%

TABLE 3-7c: BMK4000 Air/Fuel Valve Position – PROPANE		
AIR/FUEL VALVE POSITION (% OPEN)	ENERGY INPUT (BTU/HR.)	BOILER ENERGY INPUT (% OF FULL CAPACITY)
18% (Stop Level)	241,000	6.0%
20%	338,000	8.5%
30%	825,000	21%
40%	1,388,000	35%
50%	1,922,000	48%
60%	2,418,000	60%
70%	2,801,000	70%
80%	3,158,000	79%
90%	3,545,000	89%
100%	4,000,000	100%

3.4.7 BMK5000N Air/Fuel Valve Position and Energy Input

TABLE 3-8a: BMK 5000N Air/Fuel Valve Position – NATURAL GAS		
AIR/FUEL VALVE POSITION (% OPEN)	ENERGY INPUT (BTU/HR.)	BOILER ENERGY INPUT (% OF FULL CAPACITY)
18% (Stop Level)	256,000	6.5%
30%	776,300	15.6%
40%	1,563,000	31.5%
50%	2,198,000	44.3%
60%	2,601,000	52.4%
70%	3,111,000	62.6%
80%	3,755,000	75.6%
90%	4,391,000	88.4%
100%	4,966,000	100.0%

TABLE 3-8b: BMK 5000N Dual Fuel Air/Fuel Valve Position – NATURAL GAS		
AIR/FUEL VALVE POSITION (% OPEN)	ENERGY INPUT (BTU/HR.)	BOILER ENERGY INPUT (% OF FULL CAPACITY)
18% (Stop Level)	246,000	4.9%
20%	346,000	6.9%
30%	846,000	17%
40%	1,384,000	28%
50%	1,883,000	38%
60%	2,442,000	49%
70%	3,019,000	60%
80%	3,669,000	73%
90%	4,350,000	87%
100%	4,999,000	100%

TABLE 3-8c: BMK 5000N Air/Fuel Valve Position – PROPANE GAS		
AIR/FUEL VALVE POSITION (% OPEN)	ENERGY INPUT (BTU/HR.)	BOILER ENERGY INPUT (% OF FULL CAPACITY)
18% (Stop Level)	241,000	4.8%
20%	338,000	6.8%
30%	825,000	17%
40%	1,388,000	28%
50%	1,922,000	38%
60%	2,418,000	48%
70%	3,028,000	61%
80%	3,672,000	73%
90%	4,316,000	86%
100%	4,999,000	100%

Table 3-8c applies to the BMK5000N Propane only model and the Dual Fuel-Propane model.

3.4.8 BMK5000 Air/Fuel Valve Position and Energy Input

TABLE 3-9a: BMK5000 Air/Fuel Valve Position and Energy Input		
Air Fuel Valve Position (% Full Open)	Boiler Energy Input	
	BTU/Hr	% of Full Capacity
10%	0	0%
18% (Stop Level)	400,000 (117 kW)	8%
30%	997,217 (292 kW)	20%
40%	1,667,848 (489 kW)	33%
50%	1,992,380 (584 kW)	40%
60%	2,486,881 (729 kW)	50%
70%	2,981,381 (874 kW)	60%
80%	3,780,230 (1108 kW)	76%
90%	4,375,500 (1282 kW)	88%
100%	5,000,000 (1465 kW)	100%

TABLE 3-9b: BMK5000 Gas Pressure De-Rating Chart				
Gas Pressure @ SSOV in inches W.C. (kPa)		Energy Input in BTU/hr	Oxygen (%O ₂)	Dating (% Full Fire)
Inlet	Outlet			
56" (13.9 kPa)	6.8" (1.70 kPa)	5,000,000 (1465 kW)	5.7	0%
14" (3.49 kPa)	6.8" (1.70 kPa)	5,000,000 (1465 kW)	5.7	0%
10" (3.23 kPa)	6.8" (1.70 kPa)	5,000,000 (1465 kW)	5.7	0%

3.4.9 BMK6000 Air/Fuel Valve Position and Energy Input

TABLE 3-10a: BMK6000 Air/Fuel Valve Position and Energy Input		
Air Fuel Valve Position (% Full Open)	Boiler Energy Input	
	BTU/Hr	% of Full Capacity
10%	0	0%
18% (Stop Level)	385,000 (113 kW)	6%
20%	400,000 (117 kW)	7%
30%	540,000 (158 kW)	9%
40%	770,000 (226 kW)	13%
50%	1,160,000 (340 kW)	19%
60%	1,650,000 (484 kW)	28%
70%	2,386,000 (699 kW)	40%
80%	3,515,000 (1030 kW)	59%
90%	4,650,000 (1362 kW)	78%

TABLE 3-10b: BMK6000 Gas Pressure De-Rating Chart				
Gas Pressure @ SSOV in inches W.C. (kPa)		Energy Input in BTU/hr	Oxygen (%O ₂)	Dating (% Full Fire)
Inlet	Outlet			
56" (13.9 kPa)	8" (1.99 kPa)	6,000,000 (1758 kW)	5.40	0%
14" (3.49 kPa)	8" (1.99 kPa)	6,000,000 (1758 kW)	5.40	0%
13" (3.23 kPa)	8" (1.99 kPa)	5,860,000 (1717 kW)	5.45	2%

SECTION 4: INITIAL START-UP

4.1 Initial Start-Up Requirements

The following are the prerequisites for the initial start-up of the Benchmark boiler:

- Complete the installation per the *Benchmark Edge: INSTALLATION Manual* (OMM-0136), including gas supply piping, vent installation and condensate drain piping. Starting a unit without proper piping, venting, or electrical systems may void the product warranty.
- Set proper controls and limits (see Section 2 or Section 6 in the *Edge Controller Manual*).

Initial start-up consists of the following:

- **REMOVE THE AIR FILTER BAG BEFORE STARTING THE UNIT.** Combustion calibration (Section 4.4: *Combustion Calibration*)
- Test safety devices (Section 5: *Safety Device Testing*)

Start-up must be successfully completed before putting the unit into service. The start-up instructions below should be followed precisely in order to operate the unit safely and at high thermal efficiency and low flue gas emissions.

Initial unit start-up ***must be*** performed by AERCO factory trained personnel, who are trained in the start-up and service of Benchmark boilers.

An AERCO Gas Fired Startup Sheet, included with each Benchmark unit, must be completed for each unit for warranty validation and a copy must be returned promptly to AERCO via e-mail at: STARTUP@AERCO.COM.

⚠ WARNING!

- **DO NOT ATTEMPT TO DRY FIRE THE UNIT.** Starting the unit without a full water level can seriously damage the unit and may result in injury to personnel and/or property damage. This situation will void any warranty.
- **REMOVE THE AIR FILTER BAG BEFORE STARTING THE UNIT.**

NOTE: AERCO recommends that the **Standby Blower Voltage** parameter be kept at 2.00 volts (the default set at the factory) to prevent flue gas recirculation.

To check, go to the Controller's **Main Menu → Advanced Setup → Performance → Fire Control → Operating Control** and verify that the **Standby Blower Voltage** parameter is set to **2.00 V**.

However, individually vented units in positive pressure boiler rooms may set **Standby Blower Voltage** between **2.00** and **0** volts to compensate.

4.2 Tools & Instruments For Combustion Calibration

To properly perform combustion calibration, the proper instruments and tools must be used and correctly attached to the unit. The following sections outline the necessary tools and instrumentation as well as their installation.

4.2.1 Required Tools & Instrumentation

The following tools and instrumentation are necessary to perform combustion calibration:

- Digital Combustion Analyzer: Oxygen accuracy to $\pm 0.4\%$; Carbon Monoxide (CO) and Nitrogen Oxide (NO_x) resolution to 1 PPM
- 0 to 16 inch W.C. (0 to 4.0 kPa) manometer or equivalent gauge and plastic tubing
- 1/4-inch NPT-to-barbed fittings for use with gas supply manometer
- Small and large flat blade screwdrivers
- Tube of silicone adhesive

4.2.2 Installing Gas Supply Manometer

A 16" W.C. (4.0 kPa) gas supply manometer (or gauge) is used in the following ways:

- Mounted on the **upstream** side of the SSOV to verify that the gas supply pressure is within the required range of 4" W.C. and 14" W.C.
- Mounted on the **downstream** side of the SSOV to monitor the gas pressure during the Combustion Calibration procedure, described in Sections 4.4.1 (Natural Gas) and 4.4.2 (Propane).

Figures 4-1a through 4-1e show where the gas supply manometer is installed on both the upstream and downstream locations.

Gas Supply Manometer Installation Instructions BMK750 – 5000N

1. Turn off the main gas supply upstream of the unit.
2. Remove the top panel and/or front panel from the boiler to access the gas train.
3. Remove the 1/4" NPT plug from the leak detection ball valve on the upstream or downstream side of the SSOV, as needed during testing, as shown in Figure 4-1a – 4-1e.
4. Install an NPT-to-barbed fitting into the tapped plug port.
5. Attach one end of the plastic tubing to the barbed fitting and the other end to the 16" W.C. (4.0 kPa) manometer.

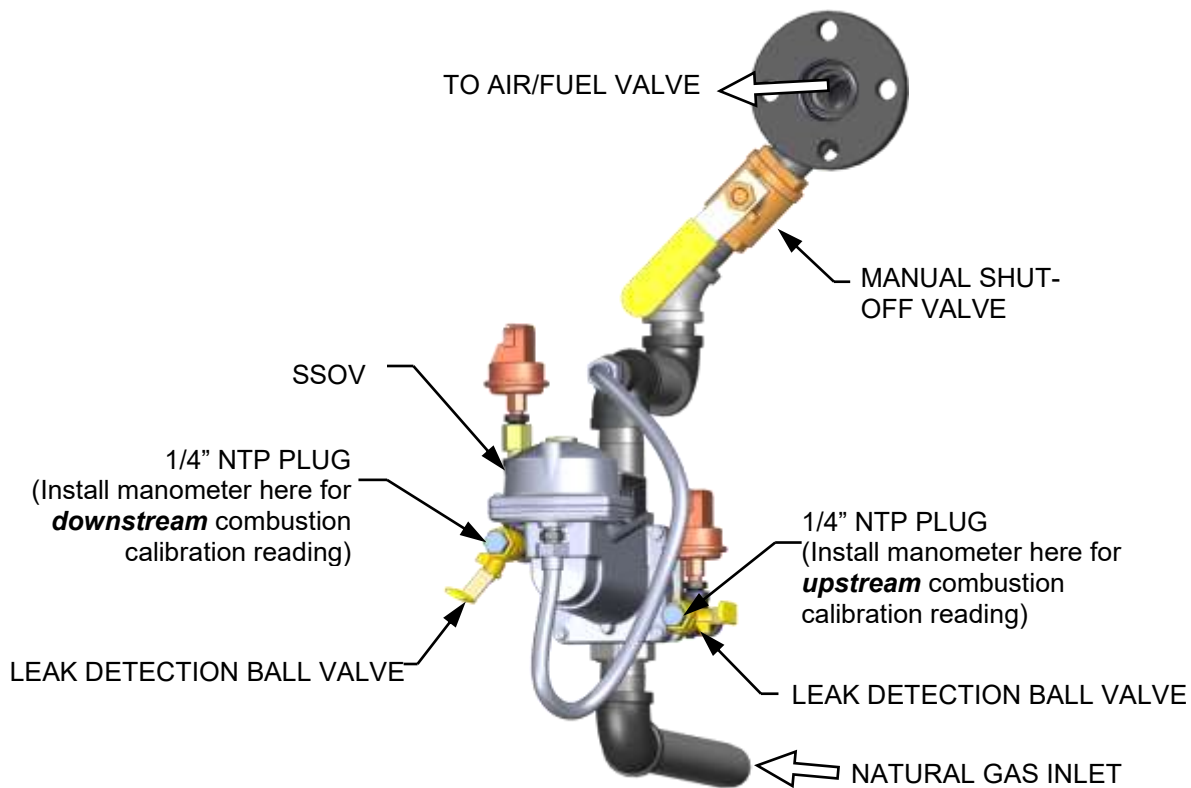

Figure 4-1a: 1/4 Inch Gas Plug Location – BMK750 & 1000 (P/N 22322 shown)

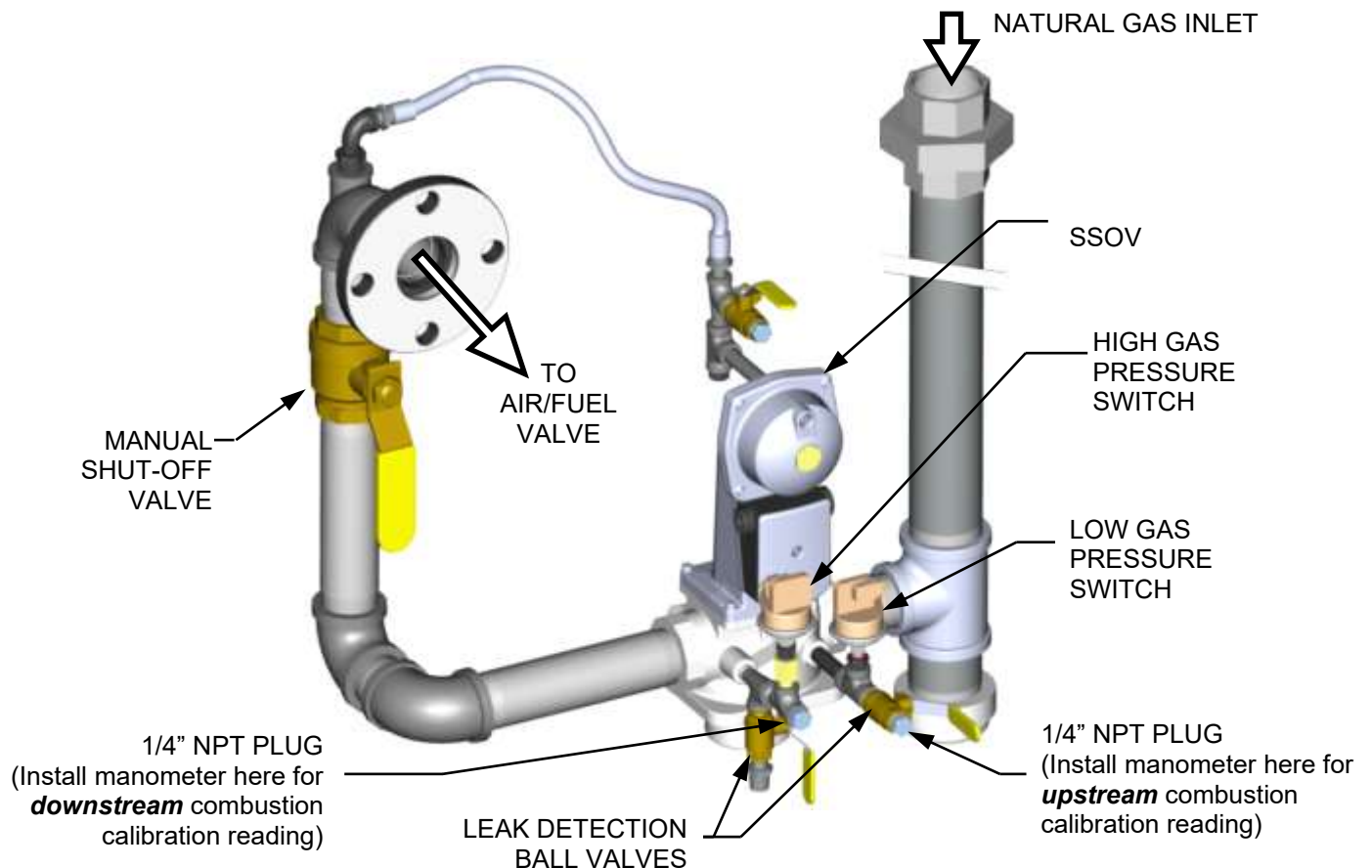

Figure 4-1b: 1/4 Inch Gas Plug Location – BMK1500 & 2000 (P/N 22314 shown)

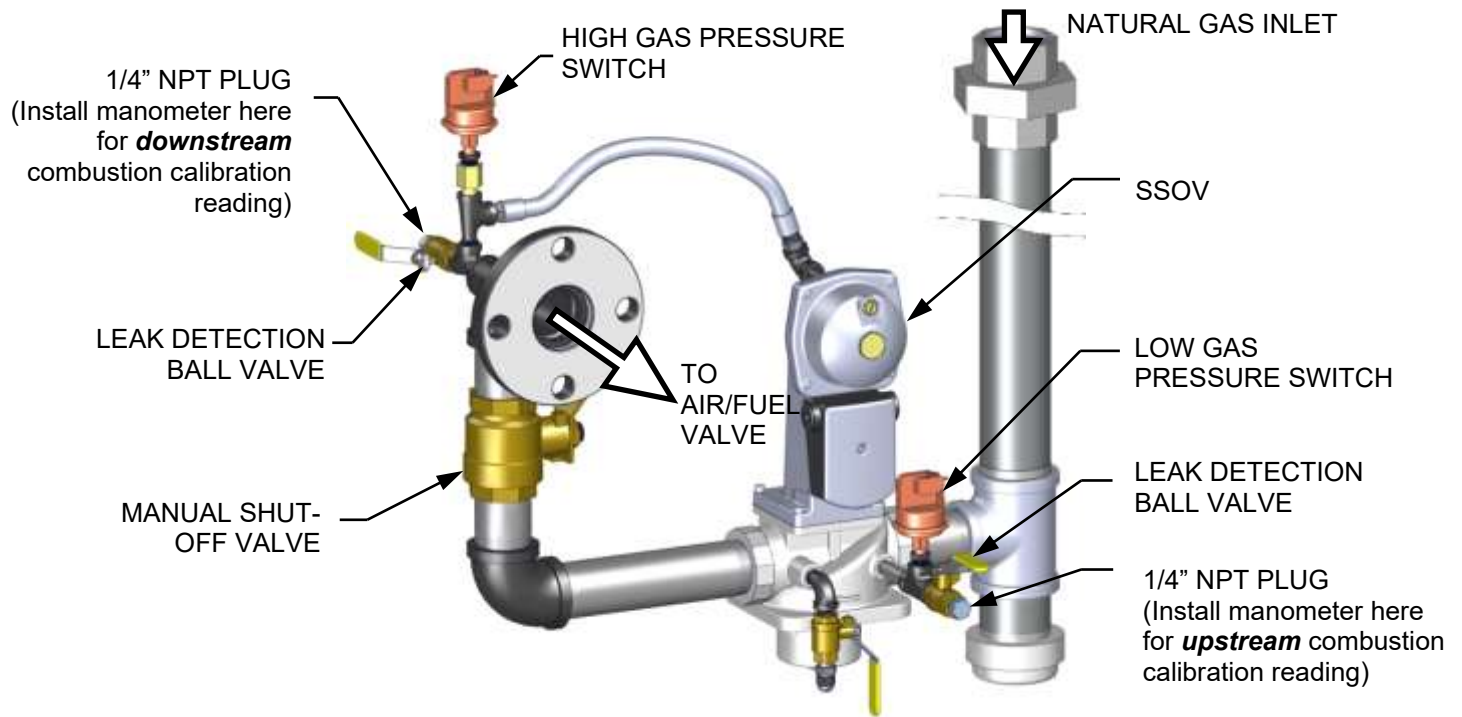

Figure 4-1c: BMK2500 1/4 Inch Gas Plug Location – BMK2500 (P/N 22318 shown)

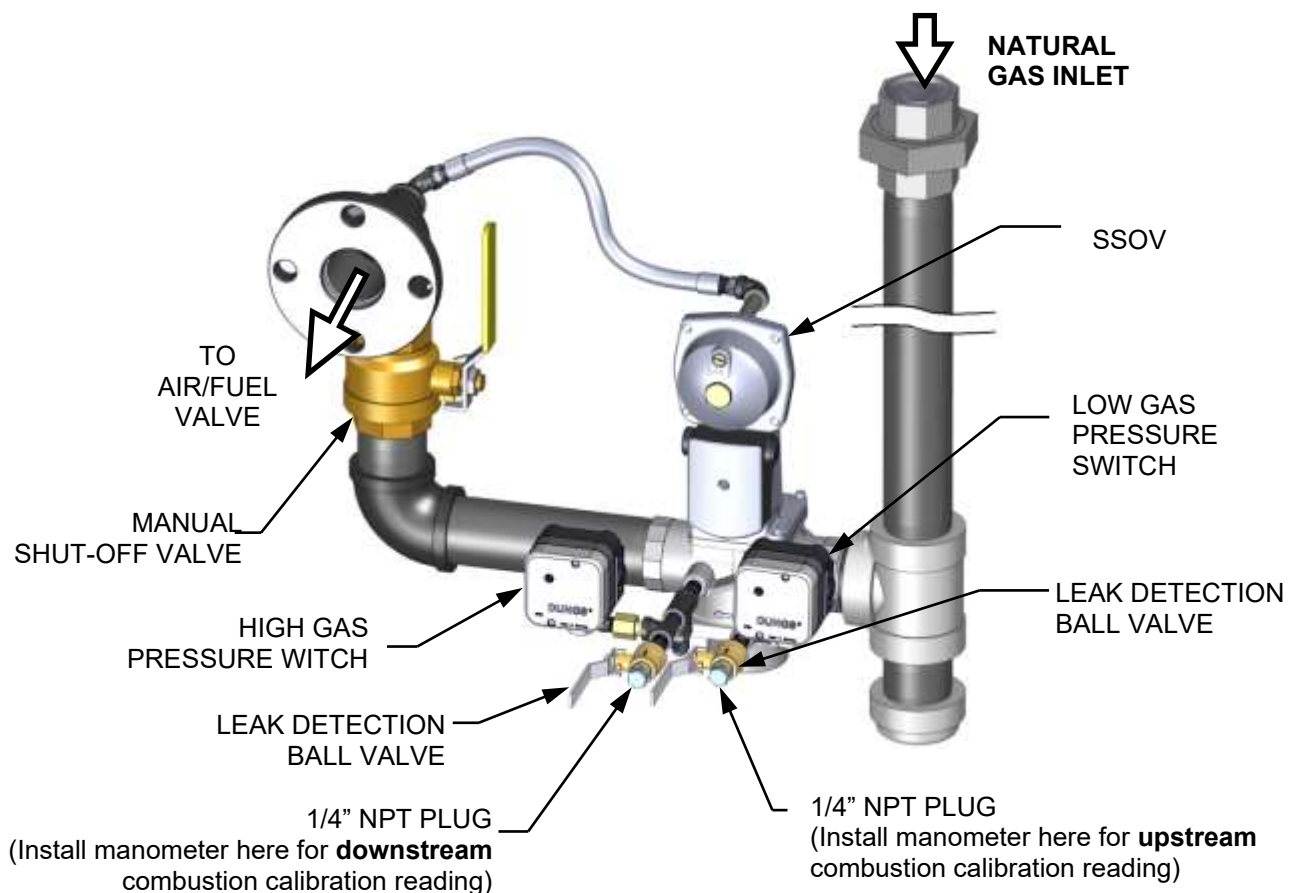

Figure 4-1d: 1/4 Inch Gas Plug Location – BMK3000 (P/N 22310 shown)

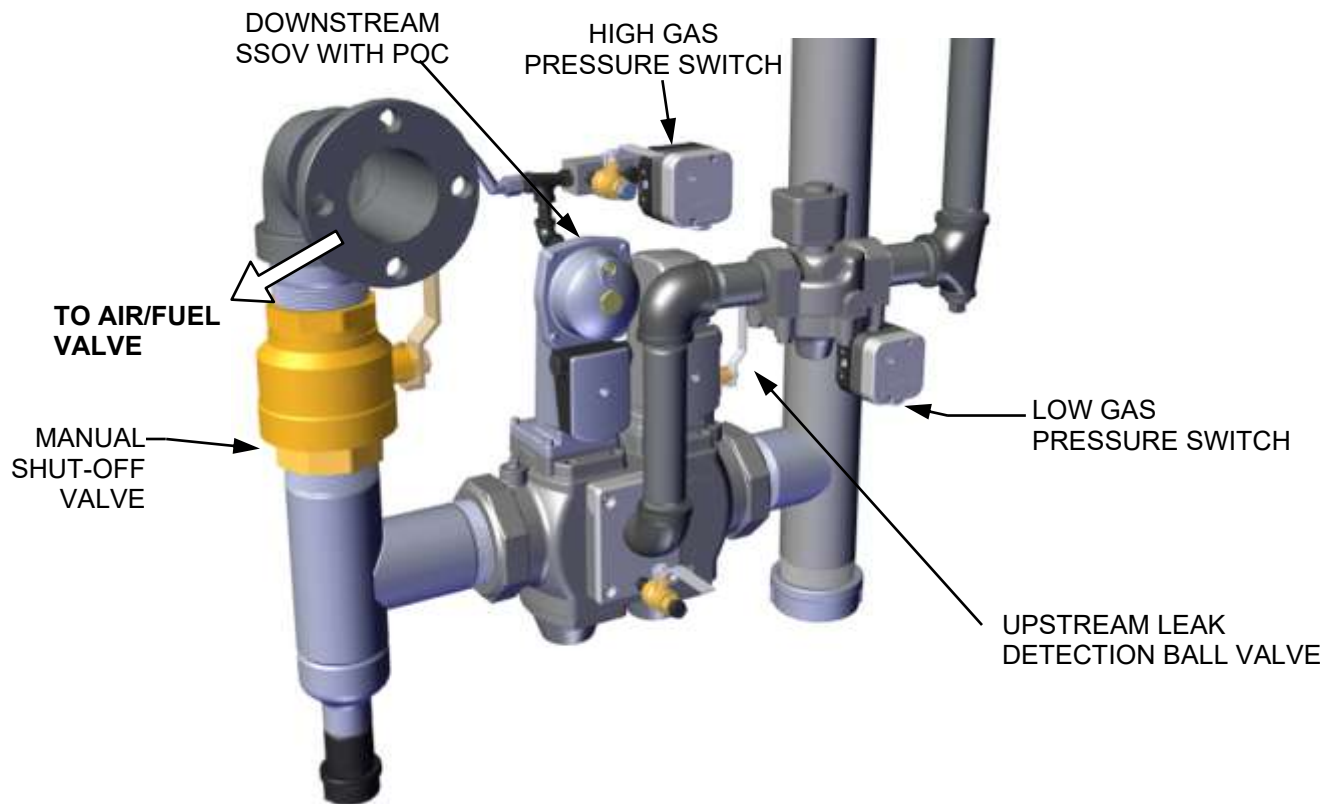

Figure 4-1e: Port Location for Combustion Calibration – BMK4000-5000N

Gas Supply Manometer Installation Instructions BMK5000 - 6000

1. Turn off the main gas supply upstream of the unit.
2. Remove the front panel from the boiler to access the gas train.
3. Connect the manometer directly to the Low and High Gas Pressure Switches, as in Figure 4-1f.

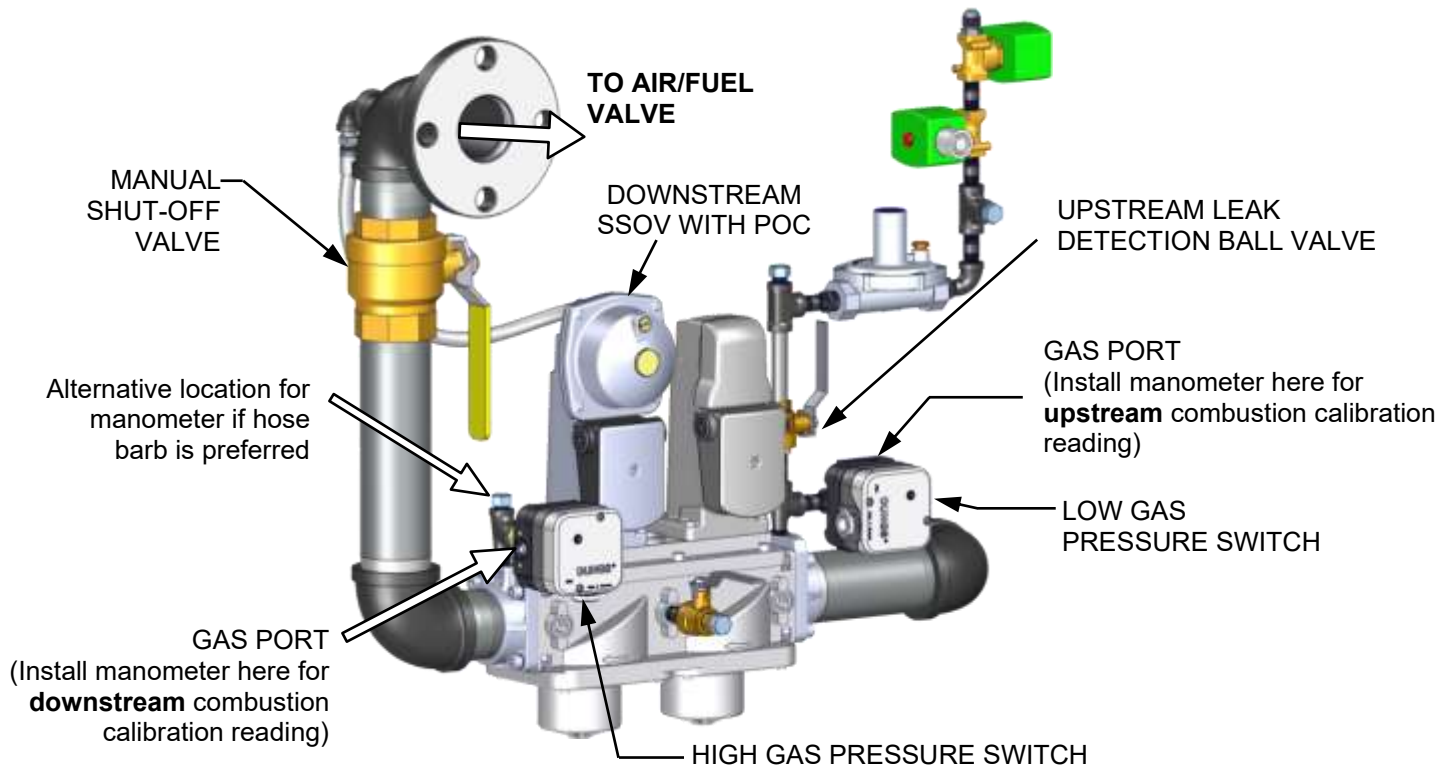

Figure 4-1f: Port Location for Combustion Calibration – BMK5000-6000

4.2.3 Accessing the Analyzer Probe Port

Benchmark units contain a 1/4" NPT port on the side of the exhaust manifold, as shown in Figure 4-2. Prepare the port for the combustion analyzer probe as follows:

1. Refer to Figure 4-2 and remove the 1/4" NPT plug from the exhaust manifold.
2. If necessary, adjust the stop on the combustion analyzer probe so it will extend mid-way into the flue gas flow. **DO NOT install the probe at this time.**

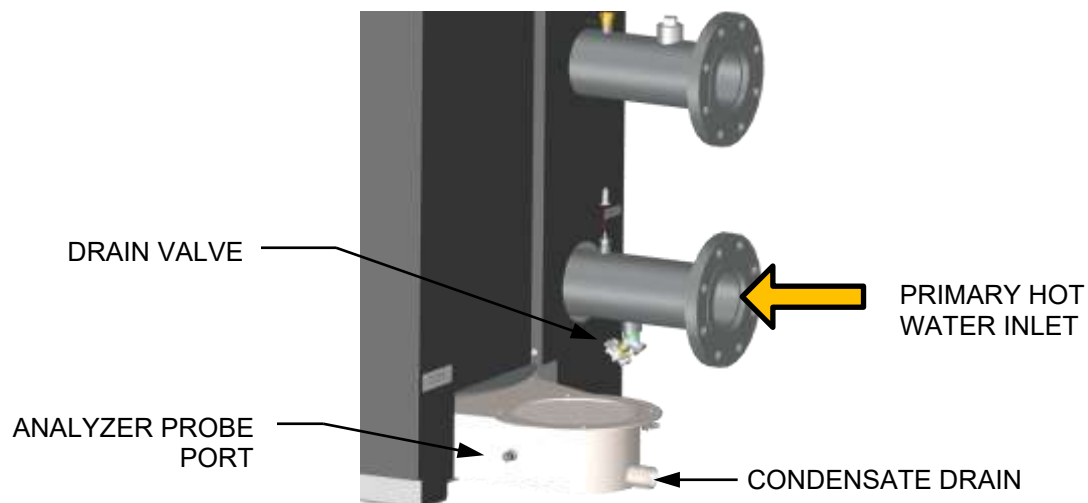

Figure 4-2: Analyzer Probe Port Location (BMK1500 shown)

4.3 Benchmark 5000 & 6000 Pilot Flame Ignition

Benchmark 5000 and 6000 boilers are equipped with an interrupted pilot ignition system. The pilot is ignited by a spark discharge within the Pilot Burner inside the combustion chamber. The input of the Pilot flame is approximately **18,000 BTU/hr. (5.3 kW)**. The Pilot Burner flame will stay ignited until the main Burner flame has stabilized and **FLAME PROVEN** appears on the Controller’s display.

The Pilot gas supply regulator **reduces** the supply pressure as follows:

- On standard pressure models, it reduces line pressure to **4.9” W.C. (1.2 kPa)**.
- On Low Gas Pressure models, it reduces line pressure to **2.0” W.C. (0.5 kPa)**.

The Pilot Burner should be inspected at the beginning of each heating season, or every 6 months of continuous operation. It is constructed of high quality, heat resistant stainless steel, however some darkening of the metal is expected. No adjustment of the Pilot should be required, however the gas pressure downstream of the regulator should be checked if an ignition issue is encountered. Refer to Figure 4-1 for test port location.

The Pilot Burner flame is proven by two Pilot Flame Detectors, located above and below the Pilot Burner. These are optical sensors inserted into tubes with quartz windows; they observe the Pilot through holes in the refractory insulation. They have a red LED which changes from flashing to steady-ON when they encounter the flicker of a flame that meets or exceeds the internal sensing threshold. (Only one of the two detectors need to sense the pilot flame throughout the ignition period). The holes in the refractory should be checked annually to ensure that the path to the Injector-Ignitor is clear.

NOTE: The Pilot Flame Detectors switch the signal to neutral when the flame is proven.

4.4 Fuel Types and Combustion Calibration

All BMK models are preconfigured at the factory to use either natural gas or propane gas and are available in dual fuel versions (natural gas and propane) (see Section 4.6). Both fuel types require different combustion calibration values, so be sure to follow the instructions for the fuel being used.

- **Natural Gas** combustion calibration: Section 4.4.1
- **Propane** combustion calibration: Section 4.4.2

4.5 Combustion Calibration

The Benchmark boiler is combustion calibrated for Standard NOx emissions (<20 ppm). For jurisdictions that require Ultra-Low NOx operation (<9 ppm), see Table 4-2 for details. The gas pressure must be within the ranges shown in Table 4-2 for each model of boiler **at full fire**.

Recalibration as part of initial start-up is necessary due to changes in the local altitude, gas BTU content, gas supply piping and supply regulators. Combustion Calibration Test Data sheets are shipped with each unit. These sheets must be filled out and returned to AERCO for proper Warranty Validation.

It is important to perform the combustion calibration procedure below to provide optimum performance and keep readjustments to a minimum.

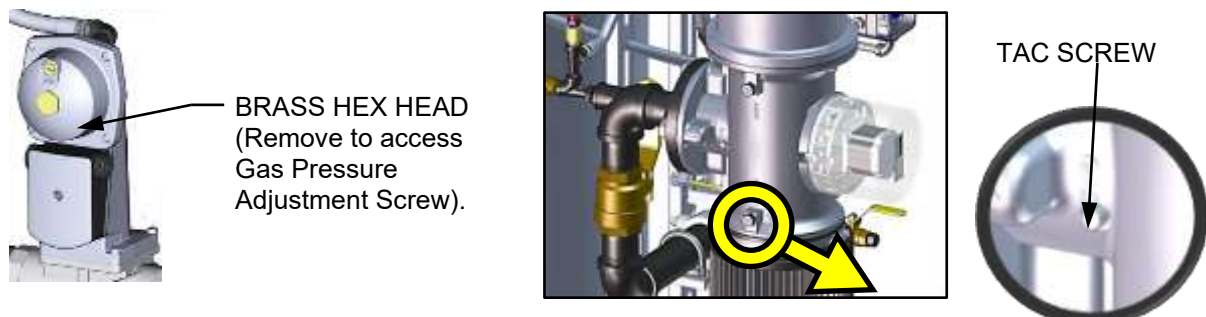

Figure 4-3: Gas Pressure Adjustment Screw and TAC Screw Location

⚠ WARNING!

- Combustion calibration and AERtrim can both alter the voltage sent to the blower and can thus interfere with each other. If AERtrim is enabled, and a change is made to any calibration point during combustion calibration, you must make a corresponding change to the same calibration point in AERtrim (see Section 9.4: AERtrim O2 Sensor Auto Calibration). If you fail to make the change in AERtrim, AERtrim may ignore the combustion calibration value and adjust the O2 to the AERtrim value instead.

4.5.1 NATURAL GAS Manual Combustion Calibration

These instructions apply only to units running **NATURAL GAS**.

1. Ensure the Edge Controller's Enable/Disable switch is set to **Disable**.
2. Open the water supply and return valves to the unit and ensure that the system pumps are running.
3. Open the **NATURAL GAS** supply valve to the unit.
4. Turn external AC power to the unit **ON**.
5. On the Controller, go to: **Main Menu → Calibration → Manual Combustion**. If necessary, enter a technician level password.
6. The first **Manual Combustion Calibration** screen appears. Complete the three steps listed before continuing with the instructions below. **In addition**, if your unit is running AERtrim, you must turn that feature off before continuing, as AERtrim will interfere with combustion calibration.

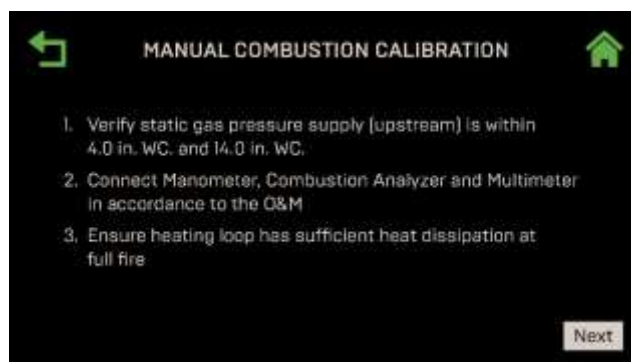

Figure 4-4: First Manual Combustion Calibration Screen

7. Connect the gas pressure manometer to the **upstream** side of the gas train's SSOV (see Section 4.2.2), and then connect the Combustion Analyzer and Multimeter (per Section 4.2.3) and ensure that the heating loop is capable of dissipating sufficient heat at full fire.
8. Verify that the incoming (upstream) gas pressure to the unit is within the allowable range (see the *Benchmark Gas Supply Guide* (TAG-0047)).
9. Once you have completed the previous step, move the manometer (or use a secondary one) to the **downstream** side of the SSOV and press **Next** to continue.

10. Choose the NOx requirement for this installation: **None**, **<= 20 PPM** or **<=9 PPM**.



Figure 4-5: Choose NOx Requirement

11. The main **Manual Combustion Calibration** screen appears. It provides two methods to ramp the unit’s valve position up or down:

- **Method 1:** Toggle through the pre-set calibration points till you reach the desired valve position, then press **Go** to go to that point (left image below).
- **Method 2:** Enable **Fine VP Step**, then manually press the **+** or **-** buttons once per 1% to bring the unit to the desired valve position (right image below).

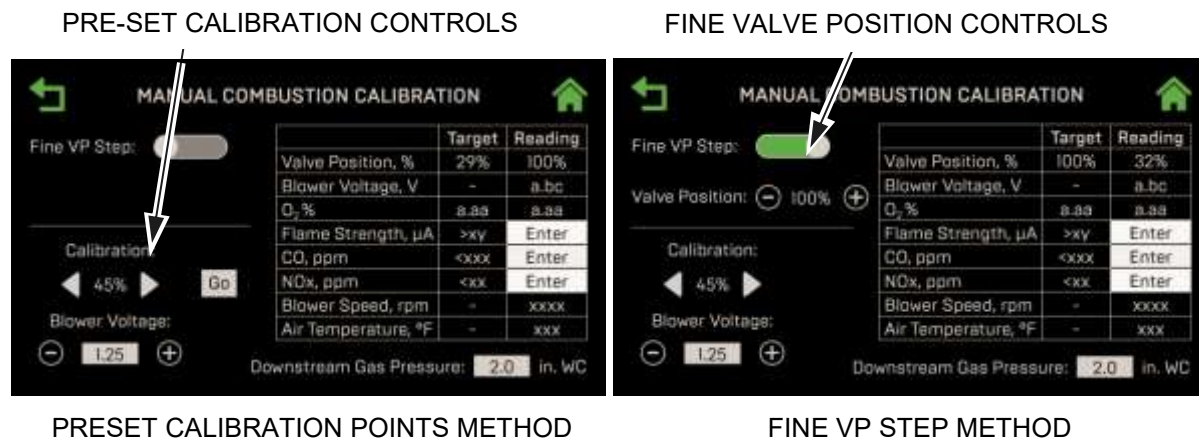

Figure 4-6: Manual Combustion Calibration Screens

12. Set the Controller’s Enable/Disable switch to **Enable**.

13. Change the valve position to 30%, press the **Go** button, then verify that the unit has ignited and is operating as expected.

14. Use the ► (Right) arrow key to change the valve position to **100%**, then press **Go**.

15. Verify that the manifold gas pressure on the **downstream** side of the SSOV is within the range shown in Table 4-1. If it isn’t, remove the brass hex nut on the SSOV actuator to access the gas pressure adjustment screw (Figure 4-3). Make adjustments using a flat-tip screwdriver, slowly rotating the gas pressure adjustment (in 1/4-turn increments) **clockwise** to **increase** gas pressure or **counterclockwise** to **reduce** it. The resulting gas pressure reading on the **downstream** manometer should fall in the range listed below.

TABLE 4-1: REFERENCE Natural Gas Manifold Gas Pressure Range @ 100% Fire Rate		
Model	Single Fuel Units	Dual Fuel Units *
BMK750	2.0" ± 0.2" W.C. (0.50 ± 0.05 kPa)	See NOTE 1
BMK1000	2.4" ± 0.4" W.C. (0.60 ± 0.10 kPa)	4.9" ± 0.2" W.C. (1.22 ± 0.05 kPa)
BMK1500	3.6" ± 0.1" W.C. (0.90 ± 0.02 kPa)	3.6" ± 0.1" W.C. (0.90 ± 0.02 kPa)
BMK2000	3.4" ± 0.2" W.C. (0.85 ± 0.05 kPa)	6.3" ± 0.1" W.C. (1.57 ± 0.02 kPa)
BMK2500	2.0" ± 0.1" W.C. (0.50 ± 0.02 kPa)	5.8" ± 0.1" W.C. (1.44 ± 0.02 kPa)
BMK3000	2.1" ± 0.2" W.C. (0.52 ± 0.05 kPa)	6.0" ± 0.2" W.C. (1.49 ± 0.05 kPa)
BMK4000	3.0" ± 0.2" W.C. (0.75 ± 0.05 kPa)	4.9" ± 0.2" W.C. (1.22 ± 0.05 kPa)
BMK5000N	1.8" ± 0.2" W.C. (0.45 ± 0.05 kPa)	4.9" ± 0.2" W.C. (1.22 ± 0.05 kPa)
BMK5000	6.3" ± 0.2" W.C. (1.56 ± 0.05 kPa)	6.3" ± 0.2" W.C. (1.57 ± 0.05 kPa)
BMK5000 (Low Gas Pressure)	2.6" ± 0.2" W.C. (0.65 ± 0.02 kPa)	N/A
BMK6000	7.9" ± 0.2" W.C. (1.97 ± 0.05 kPa)	7.9" ± 0.2" W.C. (1.97 ± 0.05 kPa)
BMK6000 (Low Gas Pressure)	1.9" ± 0.2" W.C. (0.50 ± 0.05 kPa)	N/A

* This column lists natural gas pressures on dual fuel units. For propane values, see Section 4.5.2.

NOTE 1: For BMK750 Dual Fuel, measure Natural Gas Manifold Pressure at 80% Fire Rate. Range shall be 5.0" +/- 0.2" W.C. (1.24 ± 0.05 kPa).

16. With the valve position still at 100%, insert the combustion analyzer probe into the exhaust manifold probe opening (see Figure 4-2a – 4-2c in Section 4.2.3) and allow enough time for the combustion analyzer reading to stabilize.
17. Compare the combustion analyzer’s oxygen (O₂) reading to the **O₂** value in the **Reading** column (Figure 4-6). If they differ, go to the **Main Menu → Calibration → Input/Output → O₂ Sensor** screen and adjust the **O₂ Offset** parameter, up to ±3%, to make the on-board O₂ sensor match the value from the combustion analyzer. If your combustion analyzer is correctly calibrated, and the on-board O₂ sensor cannot be made to match the analyzer, the sensor may be defective and need to be replaced.
18. Compare the **O₂** value in the **Target** and **Reading** columns. If they don’t match, adjust the **Blower Voltage** until the **O₂** value in both columns match; use either the + or – controls, or press on the field and type the value directly.
19. If adjusting the blower voltage is not sufficient to get the **O₂ Reading** column to match the **Target** column, then repeat Step 15 to adjust the gas pressure up or down within the range shown in the table, then repeat Step 18. Continue repeating Steps 15 and 18 until the gas pressure is within the range in Table 4-1 and the **O₂ Reading** column matches the **Target** column.
20. Enter the downstream manometer’s gas pressure reading in the **Downstream Gas Pressure** field. Note, this field appears only when **Valve Position % = 100%**.
21. Compare the measured nitrogen oxide (NO_x) and carbon monoxide (CO) readings to the **Target** values in Table 4-2 (reference only). If you chose the NO_x ≤9 ppm in step 9, use the values in the **Ultra-Low NO_x** columns. If you are not in a “NO_x-limited” area and/or do not have a NO_x measurement in your analyzer, set the O₂ to the value in the **Standard NO_x** column below.

TABLE 4-2: NATURAL GAS Calibration Target Values @ 100% Valve Position					
Model	Standard NO _x		Ultra-Low NO _x		CO
	O ₂ %	NO _x	O ₂ %	NO _x	
750	5.5% ± 0.2%	≤20 ppm	6.0% ± 1.0%	≤9 ppm	<100 ppm
1000	5.5% ± 0.2%	≤20 ppm	6.0% ± 1.0%	≤9 ppm	<100 ppm
1500	5.2% ± 0.2%	≤20 ppm	5.7% ± 1.0%	≤9 ppm	<100 ppm

SECTION 4 – INITIAL START-UP

2000	6.0% ± 0.2%	≤20 ppm	6.0% ± 1.0%	≤9 ppm	<100 ppm
2500	5.6% ± 0.2%	≤20 ppm	-	-	<100 ppm
3000	5.1% ± 0.2%	≤20 ppm	-	-	<100 ppm
3000 DF	5.3% ± 0.2%	≤20 ppm	-	-	<100 ppm
4000/5000N *	5.5% ± 0.2%	≤20 ppm	6.0% ± 0.2%	≤9 ppm	<100 ppm
5000/6000	5.5% ± 0.5%	≤20 ppm	6.0% ± 1.0%	≤9 ppm	<100 ppm

* The 4000, 4000DF, 5000N and 5000NDF can operate at 4.5% O₂ at full fire in jurisdictions that do not have NOx restrictions.

NOTE: These instructions assume that the inlet air temperature is between 50°F and 100°F (10°C – 37.8°C). If NOx readings exceed the target values in Table 4-1 or Table 4-3, increase the O₂ level up to 1% higher than the Target value. You must then record the increased O₂ value on the Combustion Calibration sheet.

22. On Benchmark 3000 - 6000 units *only*, record the manifold (downstream) gas pressure at 100%. This value will be used in Section 5.2.2: *Low Pressure Gas Test*, and Section 5.3.2: *High Pressure Gas Test*.

23. Once the O₂ level is within the specified range at 100%:

- Enter the **Flame Strength, NOx and CO** readings from the Combustion Analyzer and multi-meter in the Manual Combustion Calibration screen’s **Reading** column.
- Enter the same values, plus the O₂ value, on the Combustion Calibration Data Sheet provided with the unit.

24. Lower the Valve Position to the next calibration point using the ◀ (Left) arrow key (if using Method 1 in step 11) or the Fine Valve Position – (Minus) key (if using Method 2).

- BMK750 & 1000: **80%**
- BMK1500 – 6000: **70%**

25. Repeat step 17, 18 and 21 at that valve position and the rest of the valve positions in Table below corresponding to your model. The O₂, NOx and CO should stay within the ranges shown

TABLE 4-3a: NATURAL GAS BMK Final Valve Positions: BMK750/1000						
Valve Position		Standard NOx		Ultra-Low NOx		CO
Single Fuel	Dual Fuel	O ₂ %	NOx	O ₂ %	NOx	
80%	70%	5.5% ± 0.2%	≤20 ppm	6.0% ± 1.0%	≤9 ppm	<100 ppm
60%	60%	5.5% ± 0.2%	≤20 ppm	6.0% ± 1.0%	≤9 ppm	<100 ppm
45%	40%	5.5% ± 0.2%	≤20 ppm	6.0% ± 1.0%	≤9 ppm	<50 ppm
30%	30%	5.5% ± 0.2%	≤20 ppm	6.0% ± 1.0%	≤9 ppm	<50 ppm
18%	18%	5.5% ± 0.2%	≤20 ppm	6.0% ± 1.0%	≤9 ppm	<50 ppm

TABLE 4-3b: NATURAL GAS Final Valve Positions: BMK1500-2000						
Valve Position		Standard NOx		Ultra-Low NOx		CO
1500	2000	O ₂ %	NOx	O ₂ %	NOx	
70%		6.0% ± 0.2%	≤20 ppm	5.5% ± 1.0%	≤9 ppm	<100 ppm
50%		6.3% ± 0.2%	≤20 ppm	5.8% ± 1.0%	≤9 ppm	<100 ppm
40%		7.0% ± 0.2%	≤20 ppm	6.0% ± 1.0%	≤9 ppm	<50 ppm
30%		7.0% ± 0.2%	≤20 ppm	6.0% ± 1.0%	≤9 ppm	<50 ppm
16%	18%	7.0% ± 0.2%	≤20 ppm	8.0% ± 1.0%	≤9 ppm	<50 ppm

TABLE 4-3c: NATURAL GAS Final Valve Positions: BMK1500/2000 Dual Fuel				
Valve %	BMK1500 DF	BMK2000 DF	NOx	CO
	O ₂ %			
70%	6.0% ± 0.2%	6.5% ± 0.2%	≤20 ppm	<100 ppm
50%	6.3% ± 0.2%	6.5% ± 0.2%	≤20 ppm	<100 ppm
40%	7.0% ± 0.2%	6.5% ± 0.2%	≤20 ppm	<50 ppm
30%	7.0% ± 0.2%	6.5% ± 0.2%	≤20 ppm	<50 ppm
16%	8.0% ± 0.2%	5.5% ± 0.2%	≤20 ppm	<50 ppm

TABLE 4-3d: NATURAL GAS Final Valve Positions: BMK2500 – 3000					
BMK2500 Single and Dual Fuel					
Single Fuel		Dual Fuel		NOx	CO
Valve %	O ₂ %	Valve %	O ₂ %		
70%	5.9% ± 0.2%	70%	5.9% ± 0.2%	≤20 ppm	<100 ppm
50%	6.0% ± 0.2%	45%	6.2% ± 0.2%	≤20 ppm	<100 ppm
40%	6.3% ± 0.2%	30%	6.0% ± 0.2%	≤20 ppm	<50 ppm
30%	6.3% ± 0.2%	20%	5.8% ± 0.2%	≤20 ppm	<50 ppm
16%	6.0% ± 0.2%	16%	6.0% ± 0.2%	≤20 ppm	<50 ppm
BMK3000 Single and Dual Fuel					
70%	5.1% ± 0.2%	85%	5.4% ± 0.2%	≤20 ppm	<100 ppm
50%	6.1% ± 0.2%	65%	5.5% ± 0.2%	≤20 ppm	<100 ppm
40%	5.0% ± 0.2%	45%	5.7% ± 0.2%	≤20 ppm	<50 ppm
30%	6.4% ± 0.2%	30%	5.6% ± 0.2%	≤20 ppm	<50 ppm
14%	6.4% ± 0.2%	14%	6.2% ± 0.2%	≤20 ppm	<50 ppm

TABLE 4-3e: NATURAL GAS Final Valve Positions: BMK4000					
Valve Position	Standard NOx		Ultra-Low NOx		CO
	O ₂ %	NOx	O ₂ %	NOx	
70%	5.5% ± 0.2%	≤20 ppm	6.0% ± 0.2%	≤9 ppm	<100 ppm
50%	5.5% ± 0.2%	≤20 ppm	6.0% ± 0.2%	≤9 ppm	<100 ppm
40%	5.5% ± 0.2%	≤20 ppm	6.0% ± 0.2%	≤9 ppm	<50 ppm
30%	5.5% ± 0.2%	≤20 ppm	6.0% ± 0.2%	≤9 ppm	<50 ppm
23%	6.0% ± 0.2%	≤20 ppm	6.5% ± 0.2%	≤9 ppm	<50 ppm

TABLE 4-3f: NATURAL GAS Final Valve Positions: 5000N					
Valve Position	Standard NOx		Ultra-Low NOx		CO
	O ₂ %	NOx	O ₂ %	NOx	
70%	5.5% ± 0.2%	≤20 ppm	7.5% ± 0.2%	≤9 ppm	<100 ppm
50%	5.5% ± 0.2%	≤20 ppm	7.5% ± 0.2%	≤9 ppm	<100 ppm
40%	5.5% ± 0.2%	≤20 ppm	7.5% ± 0.2%	≤9 ppm	<50 ppm
30%	5.5% ± 0.2%	≤20 ppm	7.5% ± 0.2%	≤9 ppm	<50 ppm
18%	6.0% ± 0.2%	≤20 ppm	7.5% ± 0.2%	≤9 ppm	<50 ppm

TABLE 4-3g: NATURAL GAS Final Valve Positions: BMK4000/5000N Dual Fuel					
Valve Position	Standard NOx		Ultra-Low NOx		CO
	O ₂ %	NOx	O ₂ %	NOx	

SECTION 4 – INITIAL START-UP

70%	5.5% ± 0.2%	≤20 ppm	6.0% ± 0.2%	≤9 ppm	<100 ppm
50%	5.5% ± 0.2%	≤20 ppm	6.5% ± 0.2%	≤9 ppm	<100 ppm
40%	5.5% ± 0.2%	≤20 ppm	6.5% ± 0.2%	≤9 ppm	<50 ppm
30%	5.5% ± 0.2%	≤20 ppm	6.5% ± 0.2%	≤9 ppm	<50 ppm
18%	5.5% ± 0.2%	≤20 ppm	5.5% ± 0.2%	≤9 ppm	<50 ppm

TABLE 4-3h: NATURAL GAS Final Valve Positions: BMK5000, Single & DF

Valve Position		Standard NOx		Ultra-Low NOx		CO
Single Fuel	Dual Fuel	O ₂ %	NOx	O ₂ %	NOx	
70%		5.5% ± 0.5%	<20 ppm	6.0% ± 1.0%	≤9 ppm	<100 ppm
50%		5.5% ± 0.5%	<20 ppm	6.0% ± 1.0%	≤9 ppm	<100 ppm
40%		5.5% ± 0.5%	<20 ppm	6.0% ± 1.0%	≤9 ppm	<50 ppm
30%		5.5% ± 0.5%	<20 ppm	6.0% ± 1.0%	≤9 ppm	<50 ppm
18%		6.0% ± 1.0%	<20 ppm	6.5% ± 1.5%	≤9 ppm	<50 ppm

NOTE: BMK5000 Low Gas Pressure (LGP) Model does not offer Ultra Low NOx settings.

TABLE 4-3i: NATURAL GAS Final Valve Positions: BMK6000, Single & DF

Valve Position		Standard NOx		Ultra-Low NOx		CO
Single Fuel	Dual Fuel	O ₂ %	NOx	O ₂ %	NOx	
70%	85%	5.5% ± 0.5%	<20 ppm	6.0% ± 1.0%	≤9 ppm	<100 ppm
50%	65%	5.5% ± 0.5%	<20 ppm	6.0% ± 1.0%	≤9 ppm	<100 ppm
40%	45%	5.5% ± 0.5%	<20 ppm	6.0% ± 1.0%	≤9 ppm	<50 ppm
30%	30%	5.5% ± 0.5%	<20 ppm	6.0% ± 1.0%	≤9 ppm	<50 ppm
18%	18%	6.0% ± 1.0%	<20 ppm	6.5% ± 1.5%	≤9 ppm	<50 ppm

NOTE: BMK6000 Low Gas Pressure (LGP) Model does not offer Ultra Low NOx settings.

- If the oxygen level at the lowest valve position is too high, and the Blower voltage is at the minimum value, you can adjust the TAC screw, which is recessed in the top of the Air/Fuel Valve (see Figure 4-3). Rotate the screw 1/2 turn **clockwise (CW) to add fuel and reduce the O₂** to the specified level. Recalibration **MUST** be performed again from 60% or 50% down to the lowest valve position after making a change to the TAC screw.

This completes the NATURAL GAS combustion calibration procedure.

4.5.2 PROPANE Gas Combustion Calibration

These instructions apply only to units running **PROPANE** gas.

1. Set the Edge Controller's Enable/Disable switch to **Disable**.
2. Open the water supply and return valves to the unit and ensure that the system pumps are running.
3. Open the **PROPANE** supply valve to the unit.
4. Turn external AC power to the unit **ON**.
5. On the Controller, go to: **Main Menu → Calibration → Manual Combustion**. If necessary, enter a technician level password.
6. The first **Manual Combustion Calibration** screen appears. Complete the three steps listed before continuing with the instructions. *In addition*, if your unit is running AERtrim, you must turn that feature off before continuing, as AERtrim will interfere with combustion calibration.

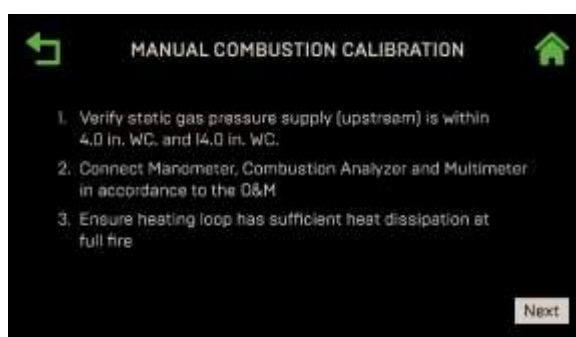

Figure 4-7: First Manual Combustion Calibration Screen

7. Connect the gas pressure manometer to the **upstream** side of the gas train's SSOV, as shown in Section 4.2.2 and connect the Combustion Analyzer and Multimeter, as shown in Section 4.2.3, and ensure that the heating loop is capable of dissipating sufficient heat at full fire.
8. Verify that the incoming gas pressure to the unit is within the allowable range (see the *Benchmark Gas Supply Guide* (TAG-0047)).
9. Once you have completed the previous step, move the manometer (or use a secondary one) to the **downstream** side of the SSOV and press **Next** to continue.
10. For the NOx requirement choose **None**.



Figure 4-8: Choose NOx Requirement

11. The main **Manual Combustion Calibration** screen appears. It provides two methods to ramp the unit's valve position up or down:

SECTION 4 – INITIAL START-UP

- **Method 1:** Toggle through the pre-set calibration points till you reach the desired valve position, then press **Go** to go to that point (left image below).
- **Method 2:** Enable **Fine VP Step**, then manually press the **+** or **-** buttons once per 1% to bring the unit to the desired valve position (right image below).

PRE-SET CALIBRATION CONTROLS

VALVE POSITION CONTROLS



Figure 4-9: Manual Combustion Calibration Screens

- Set the Controller’s Enable/Disable switch to **Enable**.
- Change the valve position to 30%, press the **Go** button, then verify that the unit has ignited successfully and is operating as expected.
- Use the ► (Right) arrow key to change the valve position to **100%**, then press **Go**.
- Verify that the gas pressure on the **downstream** side of the SSOV is within the required range shown in Table 4-4. If it isn’t, remove the brass hex nut on the SSOV actuator to access the gas pressure adjustment screw (Figure 4-3). Adjust using a flat-tip screwdriver, slowly rotating the gas pressure adjustment (in 1/4-turn increments) **clockwise** to **increase** gas pressure or **counterclockwise** to **reduce** it. The resulting gas pressure reading on the **downstream** manometer should fall in the range listed below.

TABLE 4-4: PROPANE Gas Pressure Range @ 100% Fire Rate	
Model	Nominal Gas Pressure
BMK750P	3.9" W.C. ± 0.2" W.C. (0.97 kPa ± 0.05 kPa)
BMK1000P	6.3" W.C. ± 0.2" W.C. (1.58 kPa ± 0.05 kPa)
BMK750DF	See NOTE 2
BMK1000DF	1.8" W.C. ± 0.1" W.C. (0.45 kPa ± 0.02 kPa)
1500DF & 1500P	1.4" W.C. ± 0.1" W.C. (0.35 kPa ± 0.02 kPa)
2000DF & 2000P	2.5" W.C. ± 0.1" W.C. (0.62 kPa ± 0.02 kPa)
2500DF & 2500P	2.0" W.C. ± 0.1" W.C. (0.50 kPa ± 0.02 kPa)
3000DF & 3000P	1.6" W.C. ± 0.1" W.C. (0.40 kPa ± 0.02 kPa)
4000DF & 4000P	1.5" W.C. ± 0.1" W.C. (1.12 kPa ± 0.02 kPa)
5000DF & 5000P	1.5" W.C. ± 0.1" W.C. (1.12 kPa ± 0.02 kPa)
5000DF & 5000P	2.0" ± 0.2" W.C. (0.50 to 0.05 kPa)
6000DF & 6000P	4.2" ± 0.2" W.C. (1.05 to 0.05 kPa)

NOTE 2: For BMK750 Dual Fuel, measure Propane Gas Manifold Pressure at 85% Fire Rate. Range shall be 1.8" +/- 0.1" W.C. (0.45 kPa ± 0.02 kPa)

16. With the valve position still at 100%, insert the combustion analyzer probe into the exhaust manifold probe opening (see Figure 4-2a – 4-2c in Section 4.2.3) and allow enough time for the combustion analyzer reading to stabilize.
17. Compare the oxygen (O₂) reading to the O₂ value in the **Reading** column (Figure 4-9). If they differ, go to the **Main Menu → Calibration → Input/Output → O2 Sensor** screen and adjust the **O2 Offset** parameter, up to **±3%**, to make the on-board O₂ sensor match the value from the combustion analyzer. If your combustion analyzer is correctly calibrated, and the on-board O₂ sensor cannot be made to match the analyzer, the sensor may be defective and need to be replaced.
18. Compare the O₂ value in the **Target** and **Reading** columns. If they don't match, adjust the **Blower Voltage** until the values match; use either the **+** or **-** controls, or type the value directly.
19. If adjusting the blower voltage is not sufficient to get the **O₂ Reading** column to match the **Target** column, then repeat Step 15 to adjust the gas pressure up or down within the range shown in the table, then repeat Step 18. Continue repeating Steps 15 and 18 until the gas pressure is within the range in Table 4-4 and the **O₂ Reading** column to match the **Target** column.
20. Enter the downstream manometer's gas pressure reading in the **Downstream Gas Pressure** field. Note, this field appears only when **Valve Position % = 100%**.
21. Compare the measured nitrogen oxide (NO_x) and carbon monoxide (CO) readings to the **Target** values in Table 4-5. If you are not in a "NO_x-limited" area and/or do not have a NO_x measurement in your analyzer, set the O₂ to the value in the **Oxygen (O₂) %** column in the table below.

Model	Oxygen (O ₂) %	Nitrogen Oxide (NO _x)	Carbon Monoxide (CO)
750 & 1000	5.5% ± 0.2%	≤100 ppm	<150 ppm
1500	5.2% ± 0.2%	≤100 ppm	<150 ppm
2000	6.0% ± 0.2%	≤100 ppm	<150 ppm
2500	5.0% ± 0.2%	≤100 ppm	<150 ppm
3000	5.2% ± 0.2%	≤100 ppm	<150 ppm
4000	4.5% ± 0.2%	≤100 ppm	<150 ppm
5000N	4.5% ± 0.2%	≤100 ppm	<150 ppm
5000	5.5% ± 0.5%	≤100 ppm	<150 ppm
6000	5.0% ± 0.5%	≤100 ppm	<150 ppm

NOTE: These instructions assume that the **inlet air temperature is between 50°F and 100°F (10°C – 37.8°C)**. If NO_x readings exceed the target values in Table 4-4, above, or Table 4-6, below, increase the O₂ level up to 1% higher than the Target value. You must then record the increased O₂ value on the Combustion Calibration sheet.

22. On Benchmark 3000 - 6000 units only, record the manifold (downstream) gas pressure at 100%. This value will be used in Section 5.2.2: *Low Pressure Gas Test*, and Section 5.3.2: *High Pressure Gas Test*.
23. Once the O₂ level is within the specified range at 100%:
 - Enter the **Flame Strength**, **NO_x** and **CO** readings from the Combustion Analyzer and multi-meter in the Manual Combustion Calibration screen's **Reading** column.
 - Enter the same values plus **O₂** value on the Combustion Calibration Data Sheet provided.
24. Lower the Valve Position to the next calibration point using the ◀ (Left) arrow key (if using Method 1 in step 11) or the Fine Valve Position – (Minus) key (if using Method 2).

BMK750P & 1000P: **80%**

BMK1500/2000/2500 DF & P: **70%**

BMK3000 DF & P: **85%**

BMK4000 DF & P: **70%**

BMK5000N DF & P: **70%**

BMK5000P & 6000P: **70%**

BMK5000DF & 6000DF: 85%

25. Repeat step 17, 18 and 21 at that valve position and the rest of the valve positions in the Table corresponding to your model. The O₂, NO_x and CO should stay within the ranges shown.

TABLE 4-6a: PROPANE Final Valve Positions: BMK750 – 5000N			
Valve Position	Oxygen (O₂) %	Nitrogen oxide (NO_x)	Carbon Monoxide (CO)
BMK750/1000 SINGLE Fuel			
80%	5.5% ± 0.2%	<100 ppm	<150 ppm
60%	5.5% ± 0.2%	<100 ppm	<150 ppm
45%	5.5% ± 0.2%	<100 ppm	<150 ppm
30%	6.3% ± 0.2%	<100 ppm	<100 ppm
18%	5.5% ± 0.2%	<100 ppm	<100 ppm
BMK750/1000 DUAL Fuel			
70%	5.5% ± 0.2%	<100 ppm	<150 ppm
50%	5.5% ± 0.2%	<100 ppm	<150 ppm
40%	5.5% ± 0.2%	<100 ppm	<150 ppm
30%	5.5% ± 0.2%	<100 ppm	<100 ppm
18%	5.5% ± 0.2%	<100 ppm	<100 ppm
BMK1500			
70%	5.2% ± 0.2%	<100 ppm	<150 ppm
50%	5.3% ± 0.2%	<100 ppm	<150 ppm
40%	6.2% ± 0.2%	<100 ppm	<150 ppm
30%	7.0% ± 0.2%	<100 ppm	<100 ppm
18%	8.5% ± 0.2%	<100 ppm	<100 ppm

Valve Position	Oxygen (O₂) %	Nitrogen Oxide (NO_x)	Carbon Monoxide (CO)
BMK2000			
70%	6.5% ± 0.2%	<100 ppm	<150 ppm
50%	6.5% ± 0.2%	<100 ppm	<150 ppm
40%	6.5% ± 0.2%	<100 ppm	<150 ppm
30%	6.5% ± 0.2%	<100 ppm	<100 ppm
18%	5.5% ± 0.2%	<100 ppm	<100 ppm
BMK2500			
70%	5.4% ± 0.2%	<100 ppm	<150 ppm
45%	5.6% ± 0.2%	<100 ppm	<150 ppm
30%	6.0% ± 0.2%	<100 ppm	<100 ppm
22%	5.8% ± 0.2%	<100 ppm	<100 ppm
18%	6.0% ± 0.2%	<100 ppm	<100 ppm
BMK3000			
85%	5.2% ± 0.2%	<100 ppm	<150 ppm
65%	5.4% ± 0.2%	<100 ppm	<150 ppm
45%	6.0% ± 0.2%	<100 ppm	<150 ppm
30%	6.4% ± 0.2%	<100 ppm	<100 ppm
18%	6.4% ± 0.2%	<100 ppm	<100 ppm
BMK4000			
70%	4.5% ± 0.2%	<100 ppm	<150 ppm

TABLE 4-6a: PROPANE Final Valve Positions: BMK750 – 5000N			
Valve Position	Oxygen (O ₂) %	Nitrogen oxide (NO _x)	Carbon Monoxide (CO)
50%	5.5% ± 0.2%	<100 ppm	<150 ppm
40%	5.5% ± 0.2%	<100 ppm	<150 ppm
30%	5.5% ± 0.2%	<100 ppm	<100 ppm
18%	5.5% ± 0.2%	<100 ppm	<100 ppm
BMK5000N			
70%	4.5% ± 0.2%	<100 ppm	<150 ppm
50%	5.5% ± 0.2%	<100 ppm	<150 ppm
40%	5.5% ± 0.2%	<100 ppm	<150 ppm
30%	5.5% ± 0.2%	<100 ppm	<100 ppm
18%	5.5% ± 0.2%	<100 ppm	<100 ppm

TABLE 4-6b: PROPANE Final Valve Positions: BMK5000 & 6000				
Valve Position		Oxygen (O ₂) %	Nitrogen Oxide (NO _x)	Carbon Monoxide (CO)
Single-Fuel	Dual-Fuel			
BMK5000				
70%	70%	5.5% ± 0.5%	<100 ppm	<150 ppm
50%	50%	5.5% ± 0.5%	<100 ppm	<150 ppm
40%	40%	5.5% ± 0.5%	<100 ppm	<150 ppm
30%	30%	5.5% ± 0.5%	<100 ppm	<150 ppm
18%	18%	6.0% ± 1.0%	<100 ppm	<150 ppm
BMK6000				
70%	85%	5.5% ± 0.5%	<100 ppm	<150 ppm
50%	65%	5.5% ± 0.5%	<100 ppm	<150 ppm
40%	45%	5.5% ± 0.5%	<100 ppm	<150 ppm
30%	30%	5.5% ± 0.5%	<100 ppm	<150 ppm
18%	18%	6.0% ± 1.0%	<100 ppm	<150 ppm

NOTE: If NO_x readings exceed the target values in Table 4-6a and 4-6b, increase the O₂ level up to 1% higher than the listed calibration range in the table. Record the increased O₂ value on the Combustion Calibration sheet.

26. If the oxygen level at the lowest valve position is too high, and the Blower voltage is at the minimum value, you can adjust the TAC screw, which is recessed in the top of the Air/Fuel Valve (see Figure 4-3). Rotate the screw 1/2 turn **clockwise (CW) to add fuel and reduce the O₂** to the specified level. Recalibration **MUST** be performed again from 60% or 50% down to the lowest valve position after making a change to the TAC screw.

This completes the PROPANE gas combustion calibration procedure.

4.6 Reassembly

Once the combustion calibration adjustments are properly set, the unit can be reassembled for service.

1. Set the Enable/Disable switch to the **disabled** position.
2. Disconnect AC power from the unit.
3. Shut off the gas supply to the unit.
4. Remove the manometer and barbed fittings and reinstall the NPT plug using a suitable pipe thread compound.
5. Remove the combustion analyzer probe from the 1/4" vent hole in the exhaust manifold and then replace the 1/4" NPT plug in the vent hole.
6. Replace all previously removed sheet metal enclosures on the unit.

4.7 Dual Fuel Switchover

All Benchmark Dual Fuel models contain a fuel selector switch, located to the right of the I/O board, behind the front panel.

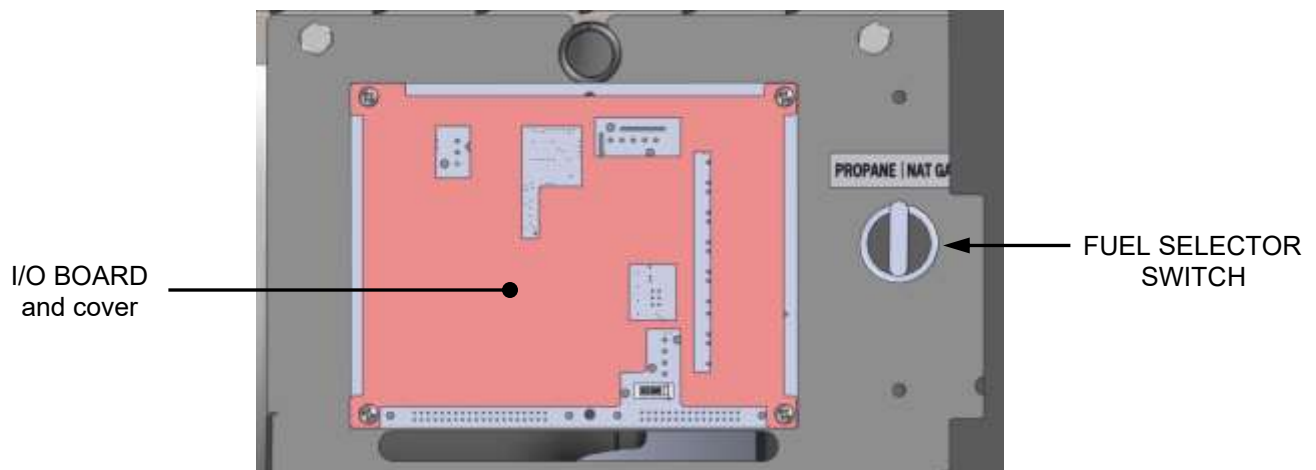

Figure 4-10: Dual Fuel Switch

Switchover from NATURAL GAS to PROPANE Instructions:

1. Set the Edge Controller's Enable/Disable switch to Disable.
2. Close the external Natural Gas supply valve.
3. Open the external Propane gas supply valve.
4. Locate the Fuel Selector Switch (see Figure 4-10), behind the front door.
5. Set the Fuel Selector Switch from NAT GAS to PROPANE.
6. Replace the front door panel previously removed from the boiler.

Switchover from PROPANE to NATURAL GAS Instructions

1. Set the Edge Controller's Enable/Disable switch to Disable.
2. Close the external Propane Gas supply valve.
3. Open the external Natural Gas supply valve.
4. Locate the Fuel Selector Switch (see Figure 4-10), behind the front door.
5. Set the Fuel Selector Switch from PROPANE to NAT GAS.
6. Replace the front door panel previously removed from the boiler.

4.8 Over-Temperature Limit Switches

The unit contains two configurable over-temperature limit controls, positioned behind the unit's front panel, under the Edge Controller:

- **Automatic Reset:** If the unit's operating temperature exceeds the limit set on the switch, the unit goes into an alarm mode and shuts the unit down. When the temperature falls 10 degrees below the limit, the unit automatically resumes operation without operator intervention. The limit range is manually adjustable from 32°F to 200°F (0°C to 93°C). The default value is 190°F (88°C).
- **Manual Reset:** If the unit's operating temperature exceeds the limit set on the switch, the switch goes into an alarm mode and shuts the unit down. The unit **cannot be restarted until the switch is reset manually**. The limit is preset to 210°F (98.9°C) and **should not be changed**.

Note the following points:

- Both switches display the temperature to which the switch is set (the temperature limit), **not** the actual temperature it is reading.
- Both switches can display temperatures in Fahrenheit or Celsius.
- The **Auto-Reset** switch is preset to 190°F (88°C) but can be adjusted as needed to suite local conditions, as described below.



Figure 4-11: Over-Temperature Limit Switches

4.8.1 Adjusting the Automatic Reset Limit Switch Temperature

Perform the following steps to adjust the Automatic Reset Limit Switch temperature setting.

1. Power the unit **ON** and remove the front panel to expose the Over-Temperature Limit switches.
2. Press the Automatic Reset Limit Switch's **SET** button: **SP** appears in the display.
3. Press the **SET** button again. The current setting stored in memory is displayed.
4. Press the ▲ or ▼ arrow buttons to change the display to the desired temperature setting.
5. When the desired temperature is displayed, press the **SET** button.
6. Press both the **SET** and ▼ arrow buttons together at the same time. This step stores the setting in memory; note that **OUT1** appears in the upper-left corner of the display as confirmation.

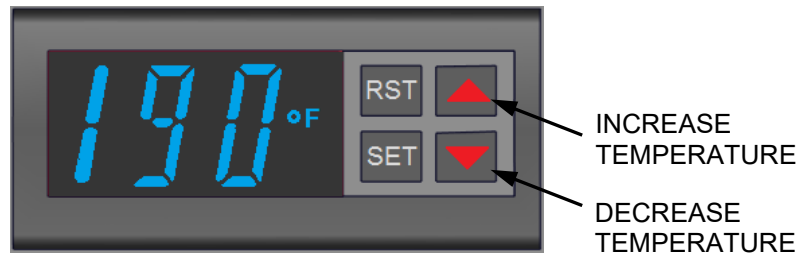

Figure 4-12: Auto-Reset Over-Temperature Limit Switch

4.8.2 Resetting the Manual Reset Limit Switch

Perform the following steps to rest the Manual Reset Limit Switch after it has gone into Alarm mode, and after the temperature has fallen at least 10 degrees below the limit.

1. Power the unit **ON** and remove the front panel to expose the Over-Temperature Limit switches.
2. Press the Manual Reset Limit Switch's **RST** (Reset) button.
3. You can now restart the unit.



Figure 4-13: Manual Reset Over-Temperature Limit Switch

4.8.3 Changing the Readout Between Fahrenheit and Celsius

Perform the following steps to change the temperature reading between Fahrenheit or Celsius.

1. Press and hold both the **Increase** and **Decrease** arrows at the same time for about 4 seconds. The display shows the temperature in Celsius and °F changes to °C.
2. To change the display back to Fahrenheit, repeat step 1.

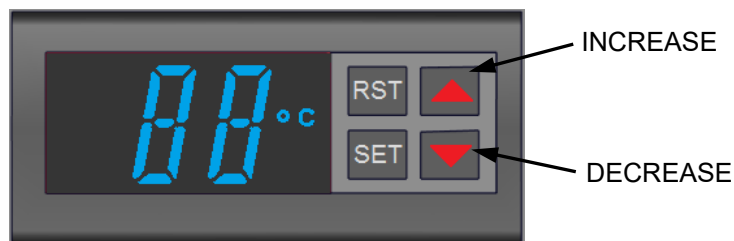

Figure 4-14: Changing the Display to Celsius

SECTION 5: SAFETY DEVICE TESTING

5.1 Testing Of Safety Devices

Periodic safety device testing is required to ensure that the control system and safety devices are operating properly. The boiler control system comprehensively monitors all combustion-related safety devices before, during and after the start sequence. The following tests check to ensure that the system is operating as designed.

Operating controls and safety devices should be tested on a regular basis or following service or replacement. All testing must conform to local codes such as ASME CSD-1.

NOTE: Manual and Auto modes of operation are required to perform the following tests. For a full explanation, see Section 4.1: Manual Run in the Edge Controller Manual (OMM-139).

NOTE: It is necessary to remove the front door and side panels to perform the tests described below.

⚡ ELECTRICAL HAZARD WARNING ⚡

- Electrical voltages up to **120 VAC (BMK750 – 2000)**, **208 or 480 VAC (BMK2500 – BMK3000)**, **480 VAC (BMK4000 & 5000N)**, or **208, 480 or 575 VAC (BMK5000 & 6000)** and **24 volts AC** may be used in this equipment. Power must be removed prior to performing wire removal or other test procedures that can result in electrical shock.

5.2 Low Gas Pressure Test

Complete the instructions in Section 5.2.1 for BMK750 – 2500 units, or in Section 5.2.2 for BMK3000 – 6000 units, which have different Low and High Gas Pressure switches.

5.2.1 Low Gas Pressure Test: BMK750 – 2500

To simulate a low gas pressure fault, refer to Figure 5-1a to 5-1c and perform the following steps:

1. Remove the front panel from the boiler to access the gas train components.
2. Close the leak detection ball valve located at the Low Gas Pressure switch.
3. Remove the 1/4" NPT plug from the ball valve at the Low Gas Pressure switch.
4. Install a **0 - 16" W.C. (0 – 4.0 kPa)** manometer or gauge where the 1/4" plug was removed.
5. Slowly open the 1/4" ball valve near the Low Gas Pressure switch.
6. On the Controller, go to **Main Menu → Diagnostics → Manual Run**.
7. Enable the **Manual Mode** parameter. The **Comm** LED will go off and the **MANUAL** LED will light.
8. Adjust the Air/Fuel Valve position **between 25% and 30%** using the **+** (Plus) and **-** (Minus) controls.
9. While the unit is firing, slowly close the external manual gas shut-off valve upstream of the unit.
10. The unit should shut down and display **Fault Lockout - Gas Pressure Fault** at approximately the pressure shown in Table 5-1 (the pressure setting of the Low Gas Pressure switch):

TABLE 5-1: LOW Gas Pressure, ± 0.2" W.C. (± 50 Pa)		
Benchmark Model	Natural Gas	Propane
BMK750/1000 FM SINGLE-Fuel	2.6" W.C. (648 Pa)	7.5" W.C. (1,868 Pa)
BMK750/1000 DUAL-Fuel	5.2" W.C. (1294 Pa)	5.2" W.C. (1294 Pa)
BMK1500/2000 FM & DBB Single-Fuel	3.6" W.C. (896 Pa)	–

SECTION 5 – SAFETY DEVICE TESTING

BMK1500/2000 Dual-Fuel	4.4" W.C. (1,096 Pa)	2.6" W.C. (648 Pa)
BMK1500/2000 DBB Dual-Fuel	2.6" W.C. (648 Pa)	2.6" W.C. (648 Pa)
BMK2500 FM & DBB Single-Fuel	3.6" W.C. (896 Pa)	–
BMK2500 Dual-Fuel	7.5" W.C. (1,868 Pa)	3.6" W.C. (897 Pa)
BMK2500 DBB Dual-Fuel	7.5" W.C. (1,868 Pa)	3.6" W.C. (897 Pa)

11. Close the ball valve near the Low Gas Pressure switch (opened in Step 5).
12. Fully open the external manual gas shut-off valve and press the Controller's **CLEAR** button.
13. The fault message should clear, the **FAULT** indicator should go off, and the unit should restart.
14. Upon test completion, close the ball valve, remove the manometer and replace the 1/4" NPT plug.

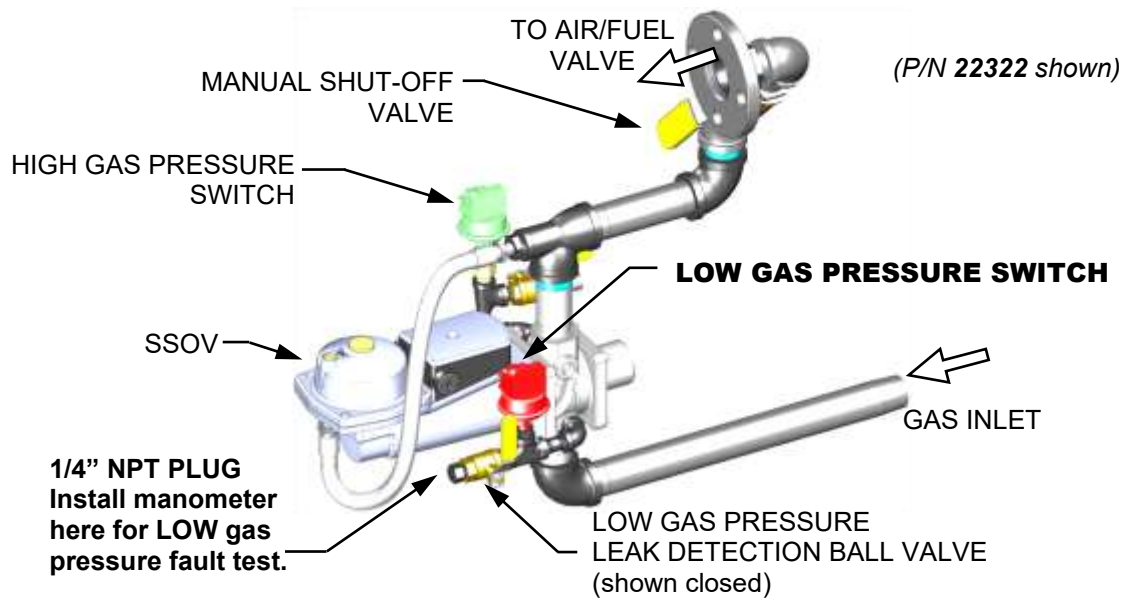

Figure 5-1a: BMK750/1000 LOW Gas Pressure Test Components

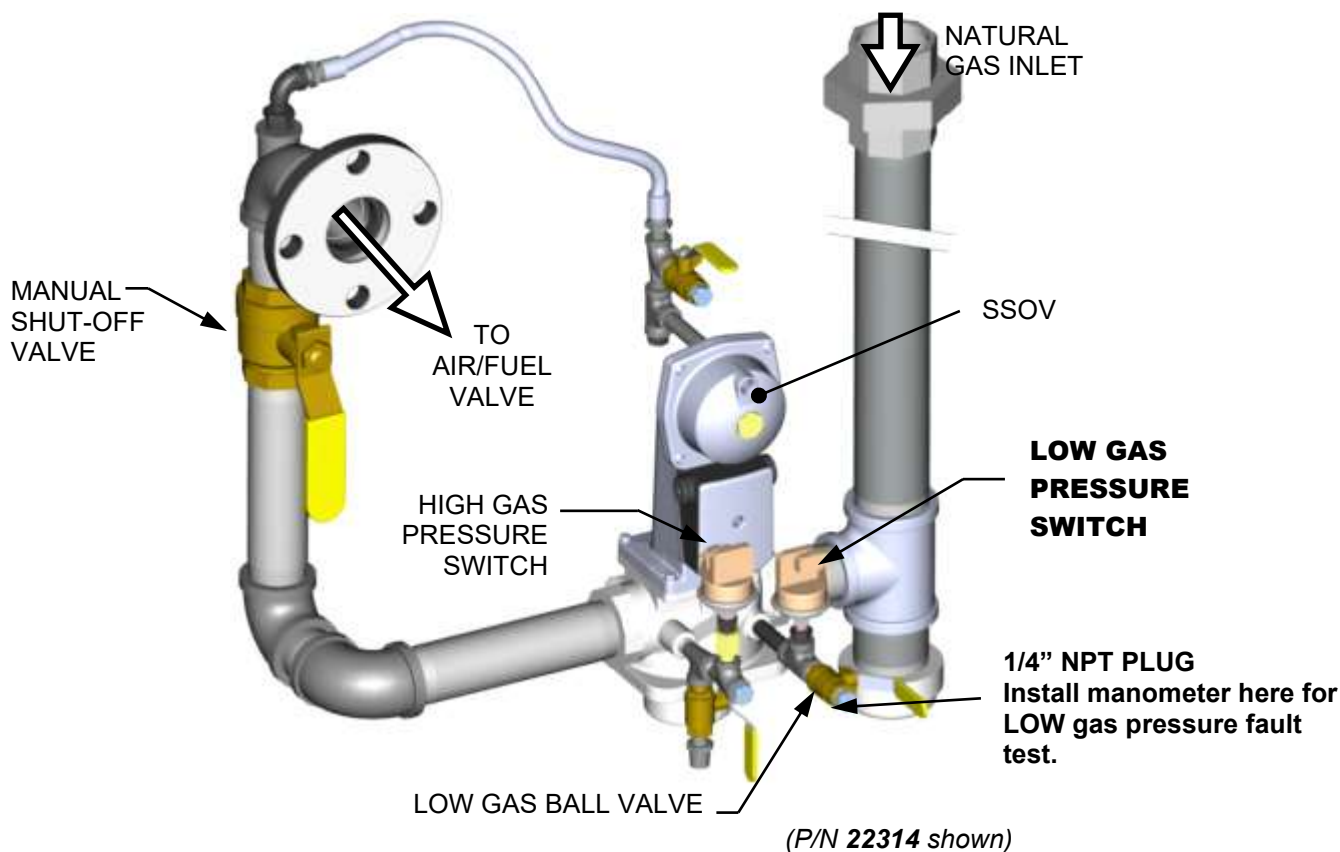

Figure 5-1b: BMK1500/2000 LOW Gas Pressure Test Components

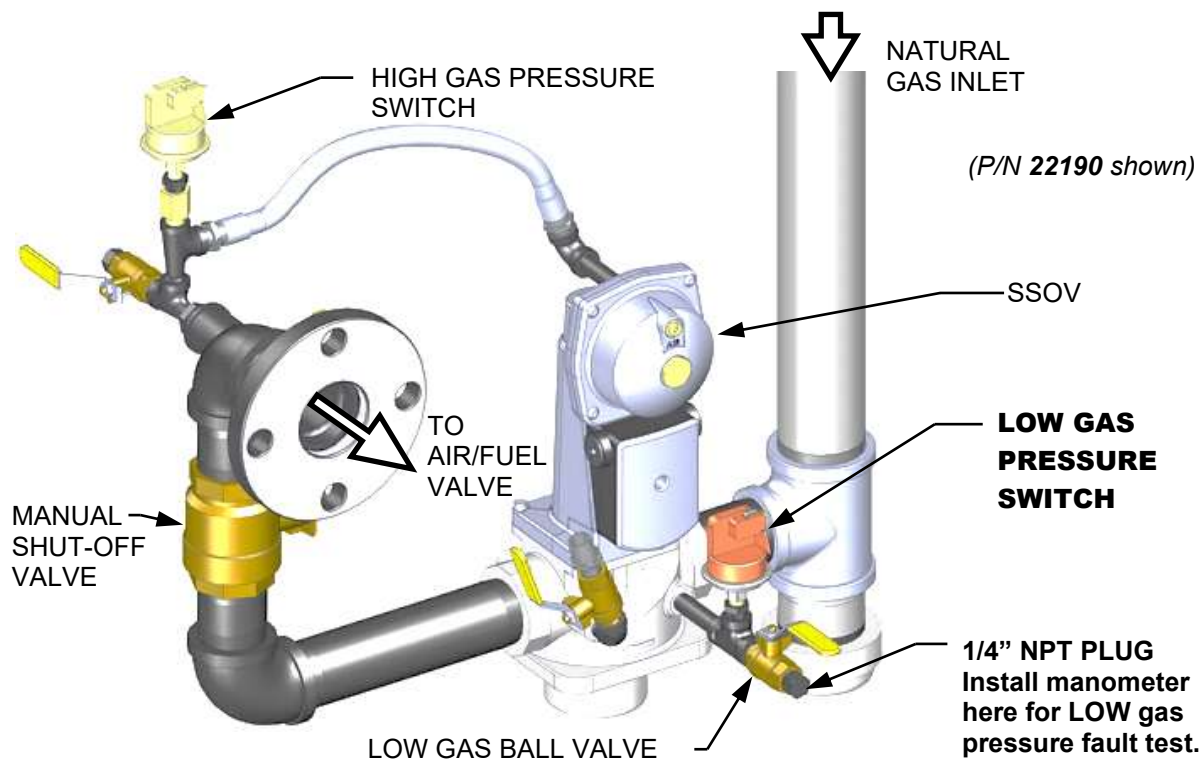

Figure 5-1c: BMK2500 LOW Gas Pressure Test Components

5.2.2 Low Gas Pressure Test: BMK3000 – 6000 Only

To simulate a low gas pressure fault on BMK3000 – 6000 units, refer to Figure 5-2a – 5-2c, below, and perform the following steps:

1. Close the **external** gas supply ball valve upstream of the unit (not shown).
2. Remove the front panel from the boiler to access the gas train components.
3. Locate the port on the top of the Low Gas Pressure switch and loosen the screw inside a few turns to open it. **Do not remove this screw completely.** Alternatively, you can remove the 1/4-inch plug shown in Figure 5-2a and 5-2b and install a hose barb fitting in that location.
4. Attach one end of the plastic tubing to the port or barb fitting and the other end to a **0 – 16” W.C. (0 – 4.0 kPa)** manometer.
5. Apply the reading of the manifold pressure taken in Step 21 of Section 4.5.1 (Natural Gas units) or Step 21 of Section 4.5.2 (Propane units) and plug it into the following formula, which calculates the minimum allowable gas pressure:

BMK3000	FM Natural Gas pressure	→ <u> </u> x 0.5 + 0.7 = <u> </u> min gas pressure
	DBB Natural Gas pressure	→ <u> </u> x 0.5 + 1.6 = <u> </u> min gas pressure
	Propane Gas pressure	→ <u> </u> x 0.5 + 0.6 = <u> </u> min gas pressure
BMK4000	FM Natural Gas pressure	→ <u> </u> x 0.5 + 0.6 = <u> </u> min gas pressure
	DBB Natural Gas pressure	→ <u> </u> x 0.5 + 0.6 = <u> </u> min gas pressure
	Propane Gas pressure	→ <u> </u> x 0.5 + 1.1 = <u> </u> min gas pressure
BMK5000N	FM Natural Gas pressure	→ <u> </u> x 0.5 + 0.9 = <u> </u> min gas pressure
	DBB Natural Gas pressure	→ <u> </u> x 0.5 + 0.9 = <u> </u> min gas pressure
	Propane Gas pressure	→ <u> </u> x 0.5 + 1.6 = <u> </u> min gas pressure
BMK5000	FM Natural Gas pressure	→ <u> </u> x 0.5 + 6.0 = <u> </u> min gas pressure
	LGP* Natural Gas pressure	→ <u> </u> x 0.5 + 0.9 = <u> </u> min gas pressure
	Propane Gas pressure	→ <u> </u> x 0.5 + 3.7 = <u> </u> min gas pressure
BMK6000	FM Natural Gas pressure	→ <u> </u> x 0.5 + 6.0 = <u> </u> min gas pressure
	LGP* Natural Gas pressure	→ <u> </u> x 0.5 + 1.3 = <u> </u> min gas pressure
	Propane Gas pressure	→ <u> </u> x 0.5 + 3.7 = <u> </u> min gas pressure

* LGP refers to Low Gas Pressure models

6. Remove the cover from the Low Gas Pressure switch and set the dial indicator to **2** (the minimum).
7. Open the external gas supply ball valve upstream of the unit.
8. On the Controller, go to: **Main Menu → Diagnostics → Manual Run** and then enable the **Manual Mode** control.
9. Adjust the Air/Fuel Valve position to **100%** using the **+** (Plus) and **-** (Minus) controls.
10. While the unit is firing, read the CO value on the combustion analyzer and slowly decrease the incoming gas supply pressure until the CO reading is **approximately 300 ppm**.
11. Take a reading of the inlet gas pressure. If the inlet pressure is below the minimum calculated in step 5, above, then increase the pressure to match the calculated minimum.
12. Slowly turn the indicator dial on the **Low Gas Pressure** switch until the unit shuts down due to a gas pressure fault.
13. Readjust the inlet gas pressure to what it was prior to the test.
14. Press the Edge Controller’s **CLEAR** button to clear the fault.
15. The fault message should clear, the red **FAULT** LED go off, and the unit should restart.

16. For Dual Fuel units, repeat the previous procedure on the **Propane** gas train, starting with the **Propane** Low Gas Pressure Switch.

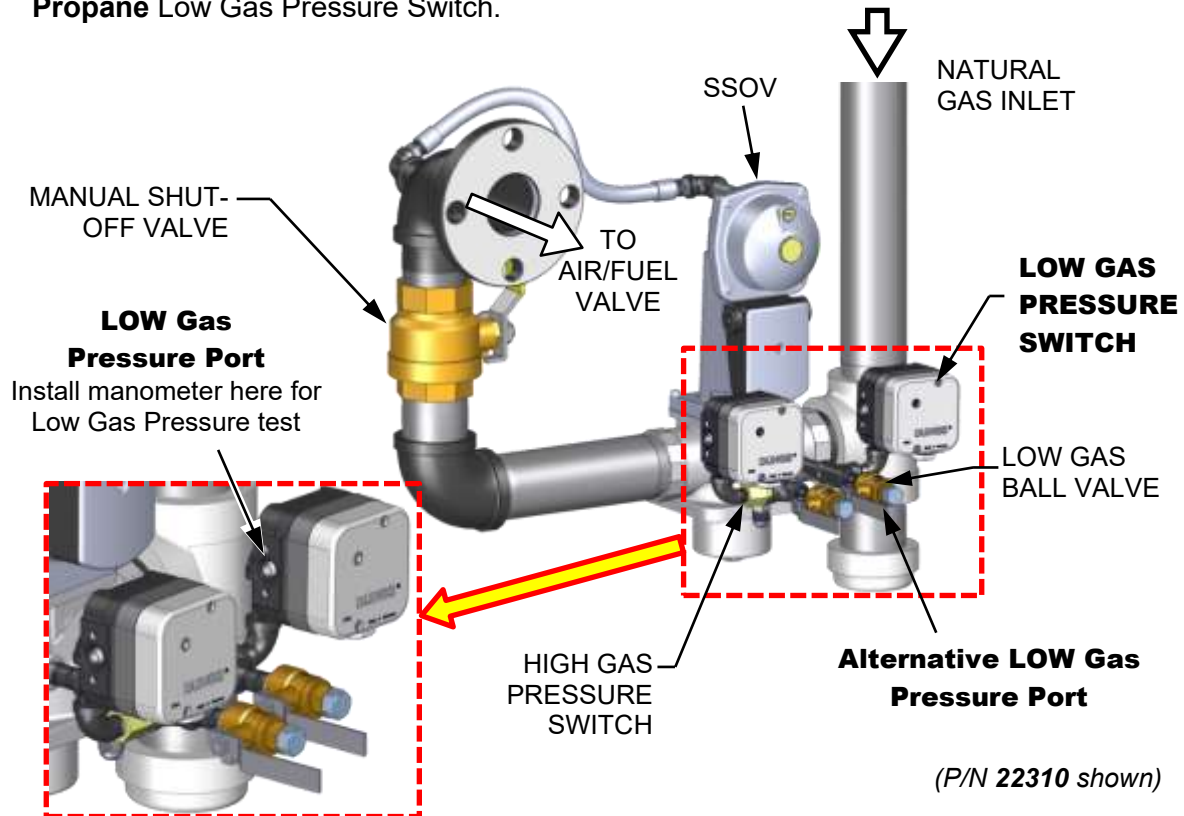

(P/N 22310 shown)

Figure 5-2a: – BMK3000 LOW and HIGH Gas Pressure Test Components

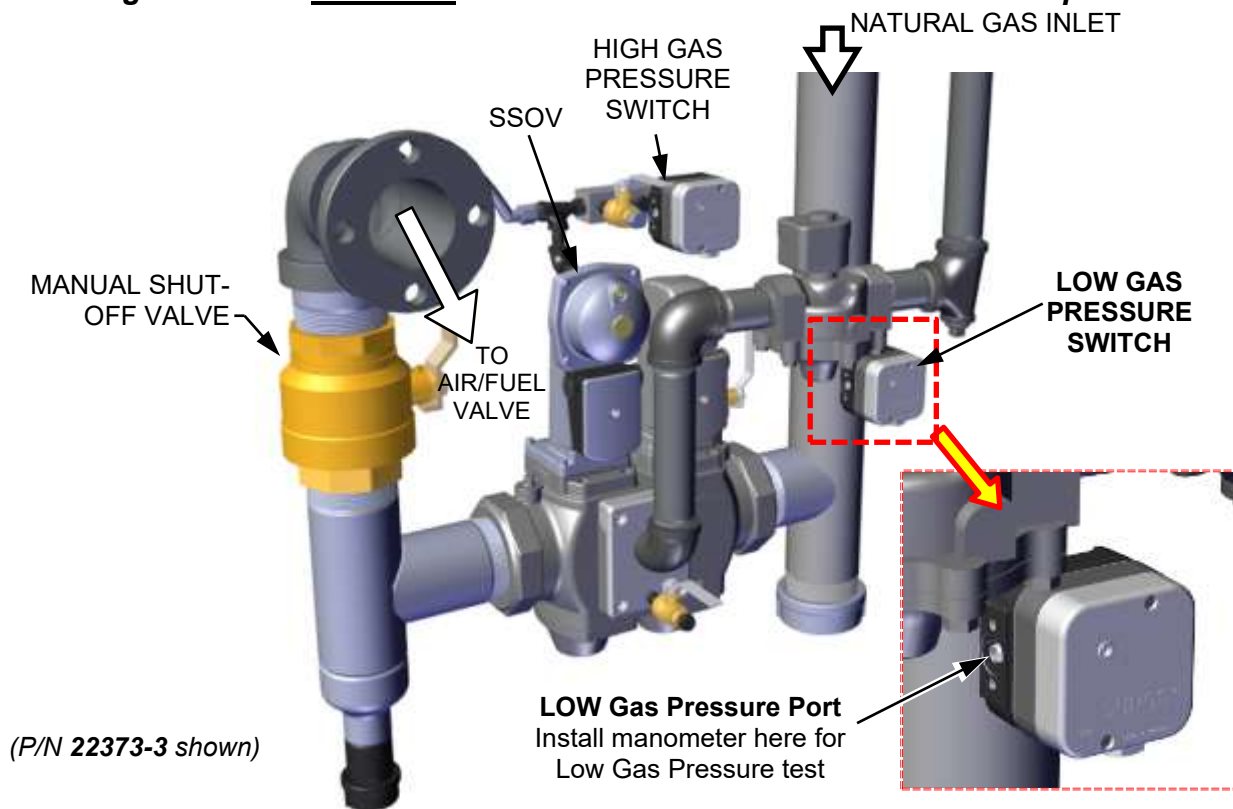

(P/N 22373-3 shown)

Figure 5-2b: BMK4000/5000N LOW and HIGH Gas Pressure Test Components

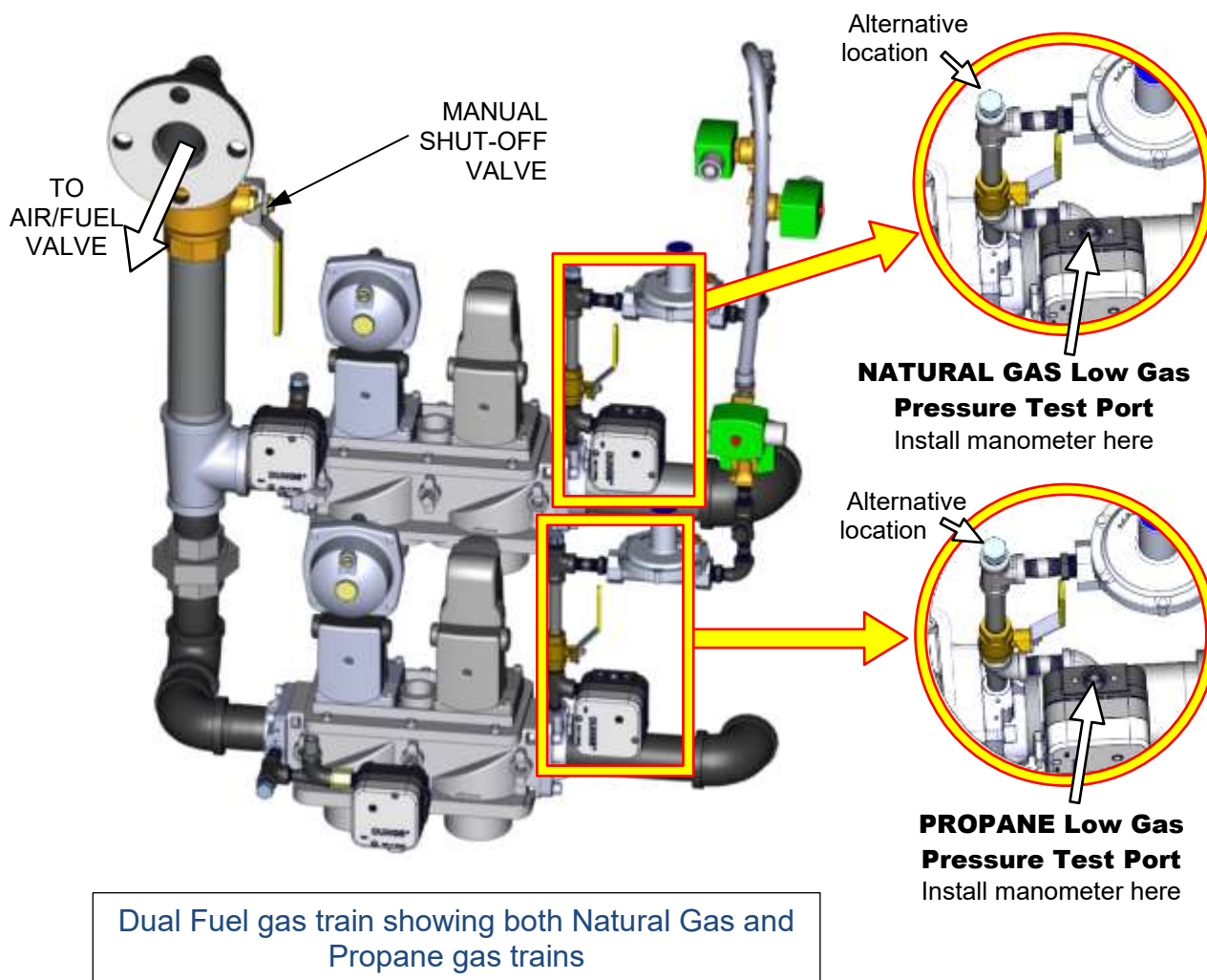

Figure 5-2c: BMK5000N/6000 LOW and HIGH Gas Pressure Test Components

5.3 High Gas Pressure Test

Complete the instructions in Section 5.3.1 for BMK750 – 2500 units, or in Section 5.3.2 for BMK3000 – 6000 units, which have different High Gas Pressure switches.

5.3.1 HIGH GAS PRESSURE TEST: BMK750 – 2500

1. Close the leak detection ball valve located at the High Gas Pressure switch.
2. Remove the 1/4" NPT plug from the High Gas pressure leak detection ball valve shown in Figures 5-3a through 5-3c.
3. Install a **0 - 16" W.C. (0 – 4.0 kPa)** manometer or gauge where the 1/4" plug was removed.
4. Slowly open the leak detection ball valve.
5. On the Controller, go to: **Main Menu → Diagnostics → Manual Run.**
6. Enable the **Manual Mode** control.
7. Set the valve position **between 25% and 30%** using the + (Plus) and – (Minus) controls.

SECTION 5 – SAFETY DEVICE TESTING

8. With the unit running, monitor the gas pressure on the manometer installed in step 2 and record the gas pressure reading.
9. Slowly increase the gas pressure using the adjustment screw on the SSOV **while counting the number of turns you make**.
10. The **FAULT** indicator should start flashing and the unit should shut down and display a **Fault Lockout - Gas Pressure Fault** message at approximately the value shown in Table 5-2 (the pressure setting of the High Gas Pressure switch). If the unit does not trip off within 0.2" W.C. of the pressure shown, the switch needs to be replaced.

TABLE 5-2: HIGH Gas Pressure, ± 0.2" W.C. (± 50 Pa)		
Benchmark Model	Natural Gas	Propane
BMK750/1000 FM Single-Fuel	4.7" W.C. (1.17 kPa)	4.7" W.C. (1.17 kPa)
BMK750/1000 DUAL-Fuel	7.0" W.C. (1.74 kPa)	2.6" W.C. (0.65 kPa)
BMK1500/2000 Single-Fuel	4.7" W.C. (1.17 kPa)	–
BMK1500/2000 DBB Single-Fuel	4.7" W.C. (1.17 kPa)	–
BMK1500/2000 Dual-Fuel	4.7" W.C. (1.17 kPa)	4.7" W.C. (1.17 kPa)
BMK1500/2000 DBB Dual-Fuel	3.5" W.C. (0.87 kPa)	3.5" W.C. (0.87 kPa)
BMK2500 FM & DBB Single-Fuel	3.0" W.C. (0.75 kPa)	–
BMK2500 Dual-Fuel	7.0" W.C. (1,74 kPa)	2.6" W.C. (0.65 kPa)
BMK2500 DBB Dual-Fuel	7.0" W.C. (1,74 kPa)	2.6" W.C. (0.65 kPa)

11. Reduce the gas pressure by returning the SSOV adjustment screw back to its original position before starting step 9 (the value recorded in step 8). This pressure should be within the range used during combustion calibration, shown in Table 4-1 (Natural Gas) and Table 4-4 (Propane gas).
12. Press the **CLEAR** button on the Edge Controller to clear the fault.
13. The fault message should clear, the **FAULT** indicator should go off and the unit should restart (if in **Manual** mode).
14. Upon test completion, close the ball valve and remove the manometer. Replace the 1/4" NPT plug removed in step 2.

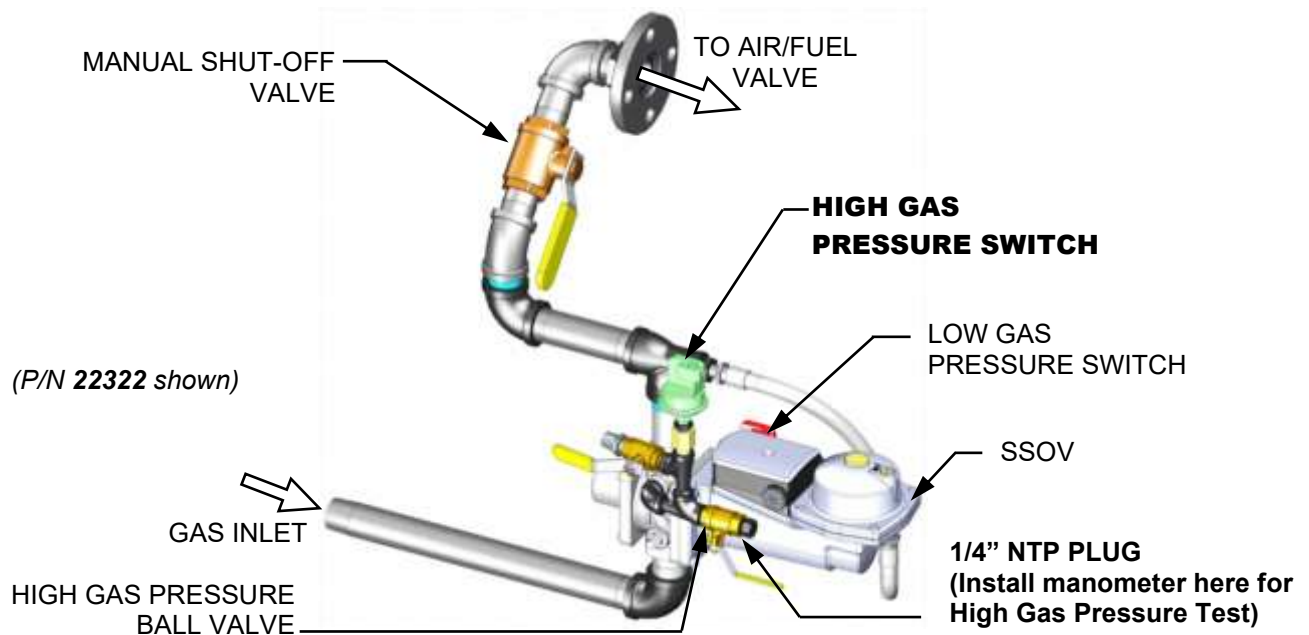

Figure 5-3a: BMK750/1000 HIGH Gas Pressure Test Components

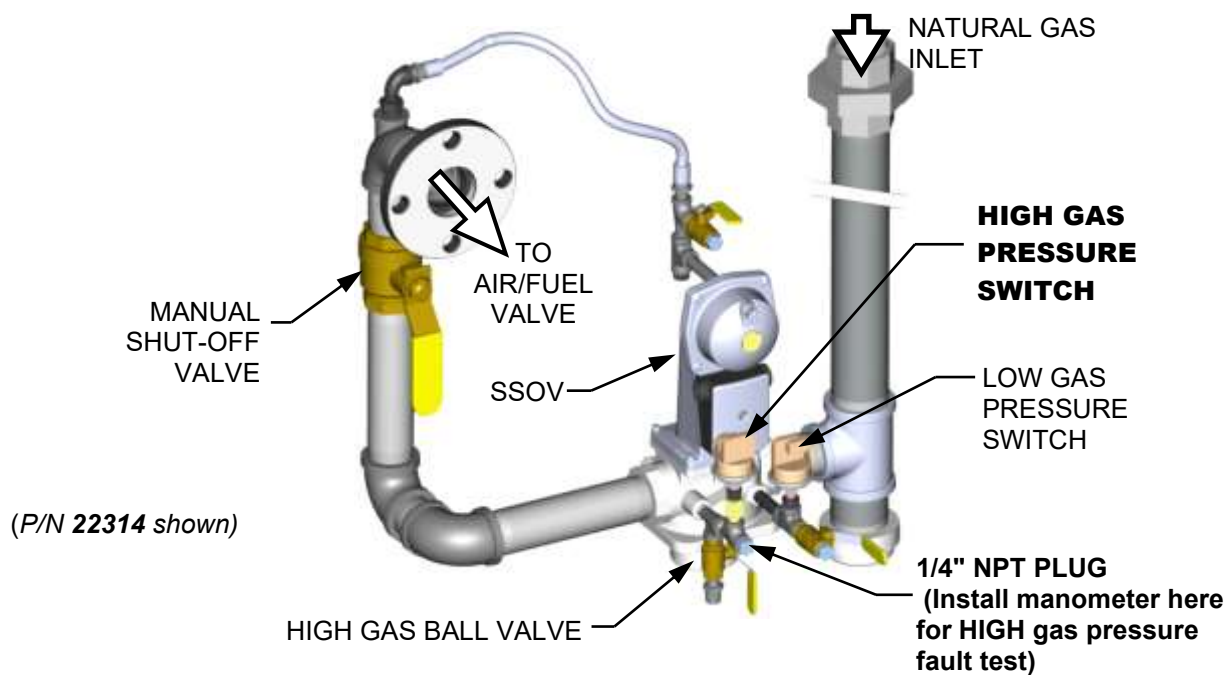

Figure 5-3b: BMK1500/2000: HIGH Gas Pressure Fault Test

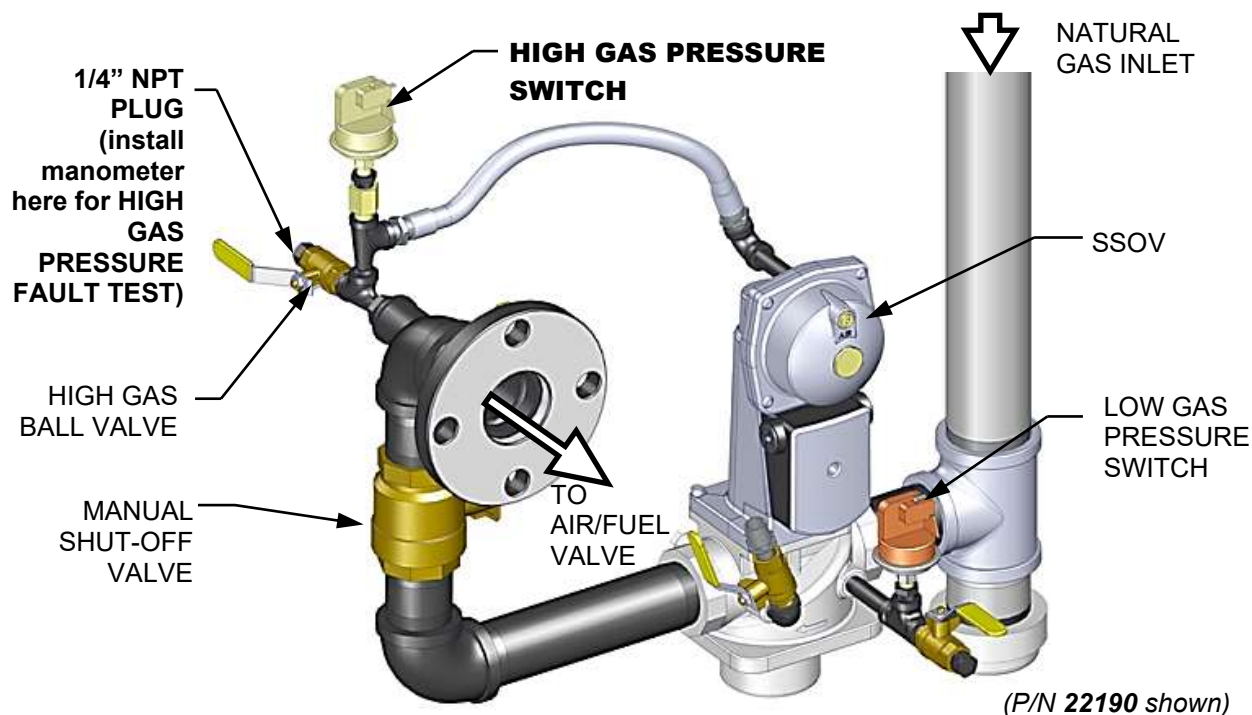

Figure 5-3c: BMK2500: HIGH Gas Pressure Fault Test

5.3.2 HIGH GAS PRESSURE TEST: BMK3000 – 6000 Only

To simulate a high gas pressure fault, refer to Figure 5-4a and 5-4b and perform the following steps:

1. Shut off the **external** gas supply by closing the external gas supply ball valve.
2. Locate the port on the side of the **High Gas Pressure** switch and loosen the screw in the port a few turns to open it. **Do not completely remove the screw.** Alternatively, you can remove the 1/4-inch plug shown in Figure 5-4a and 5-4b and install a hose barb fitting in that location.
3. Attach one end of the plastic tubing to the port or barb fitting and the other end to a **0 – 16” W.C. (0 – 4.0 kPa)** manometer.
4. Apply the reading of the manifold pressure taken in Step 21 of Section 4.4.1 (natural gas units) or Step 21 of Section 4.4.2 (propane units) and plug it into the following formula, which calculates the **maximum** allowable gas pressure:

BMK3000	Natural Gas Pressure → _____ x 1.5 = _____ max gas pressure
BMK4000 & 5000N	Natural Gas Pressure → _____ x 1.5 = _____ max gas pressure
BMK5000 & 6000	Natural Gas Pressure → _____ x 1.5 = _____ max gas pressure
	Propane Gas Pressure → _____ x 1.5 = _____ max gas pressure

5. Remove the cover from the High Gas Pressure switch and **set the dial indicator to 20** (max).
6. Open the **external** gas supply ball valve upstream of the unit.
7. On the Controller, go to: **Main Menu → Diagnostics → Manual Run** and enable **Manual Mode**.
8. Use the **+** (Plus) and **-** (Minus) controls to bring the unit up to 100%.
9. Slowly increase the manifold gas supply pressure by turning the Gas Pressure Adjustment Screw in the Downstream SSOV (Figure 5-2) while reading the CO level on the combustion analyzer. Adjust the manifold pressure until the CO reading is **approximately 300 ppm**. Note the number of turns you make, as you will turn it back to its original position in step 13, below.
10. Take a reading of the manifold gas pressure. If the manifold pressure is **greater** than the maximum calculated in step 3, then use the Gas Pressure Adjustment Screw to decrease the manifold pressure until it is at the maximum allowed.
11. Slowly turn the indicator dial on the High Gas Pressure switch until the unit shuts down due to a gas pressure fault. This is the setpoint.
12. Press the **RESET** button on the High Gas Pressure switch (see Figure 5-4, below).
13. Readjust the manifold gas supply pressure to what it was before it was increased in step 9.
14. Press the **CLEAR** button on the Edge Controller to clear the fault.
15. Fire the unit back up to ensure gas pressure out of the SSOV is set as it was originally.
16. Upon test completion, close the ball valve and remove the manometer fitting from the port, and then turn the port screw clockwise till the port is closed.
17. For Dual Fuel gas trains, repeat this procedure on the **Propane** gas train, starting with opening the port on the **Propane** High Gas Pressure Switch, as shown in Figure 5-4b.

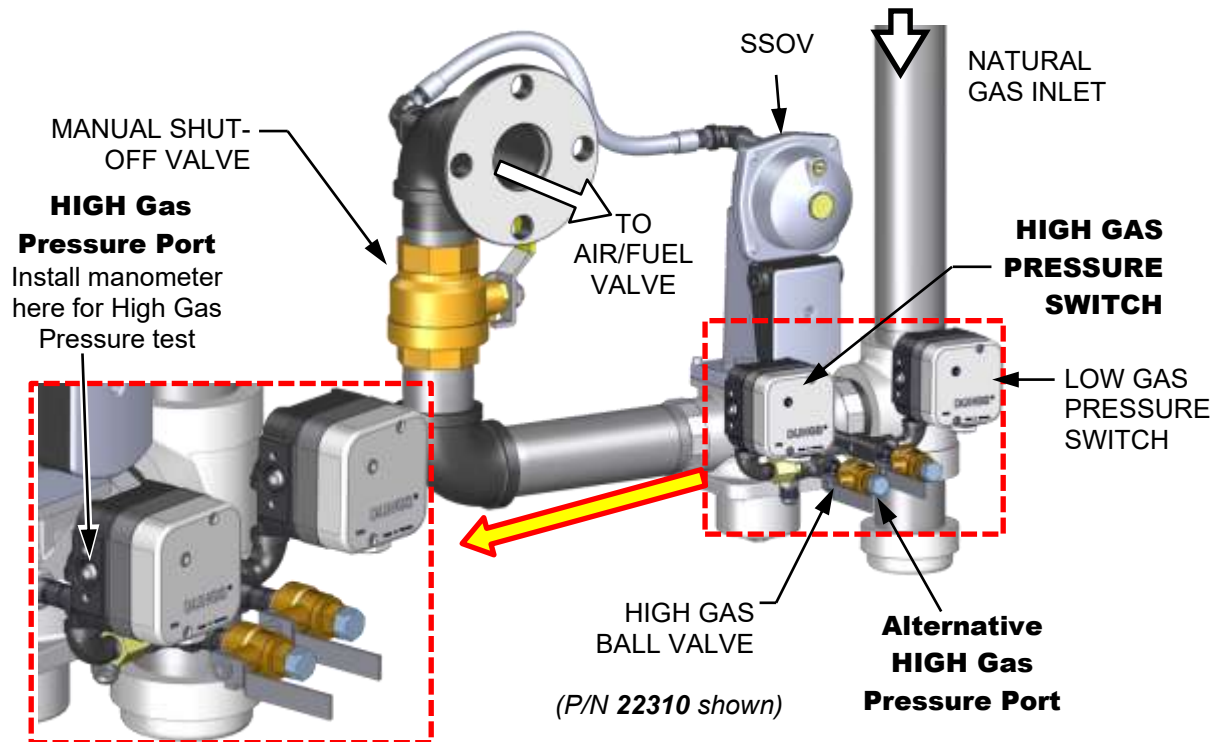

Figure 5-4a: BMK3000 HIGH Gas Pressure Test Components

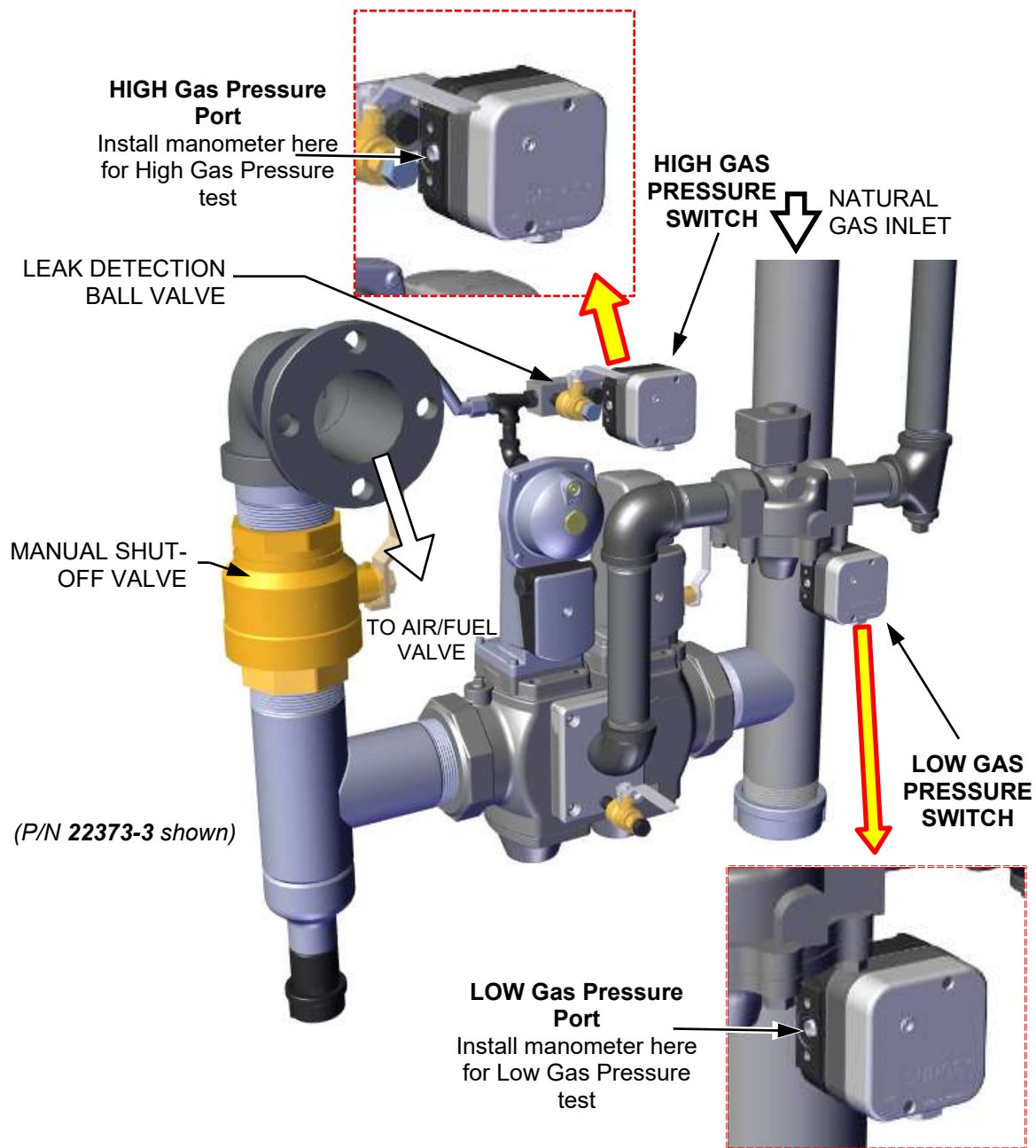

Figure 5-4b: BMK4000/5000N HIGH Gas Pressure Test Components

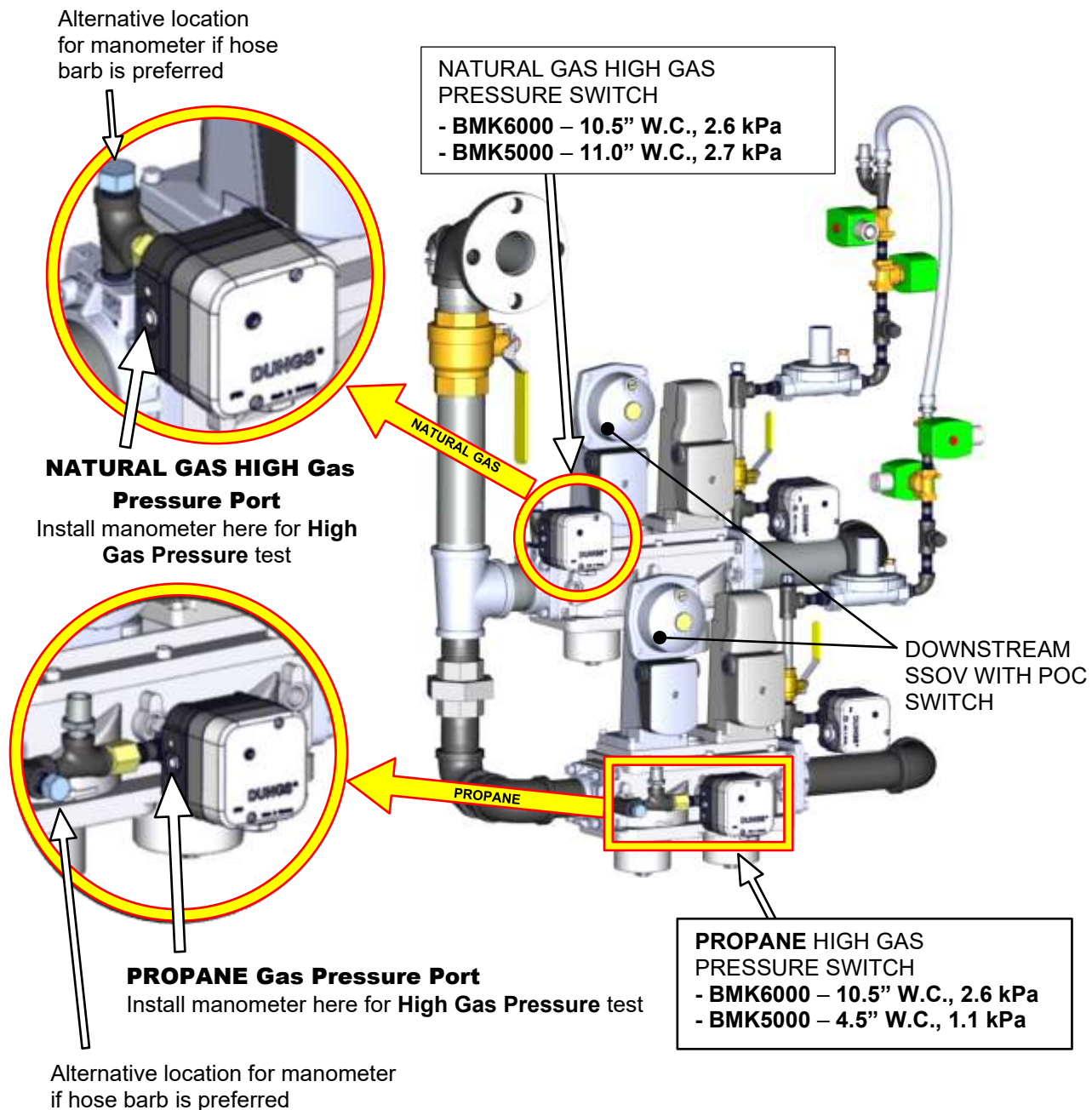

Figure 5-4c: BMK5000/6000 High Gas Pressure Test Components

5.4 Low Water Level Fault Test

To simulate a low water level fault, proceed as follows:

1. Set the Controller's **Enable/Disable** switch to **Disable**.
 2. Close the water shut-off valves in the supply and return piping to the unit.
 3. Slowly open the drain valve on the rear of the unit. If necessary, the unit's relief valve may be opened to aid in draining.
 4. Continue draining the unit until a **Low Water Level** fault message is displayed and the FAULT indicator flashes.
 5. On the Controller, go to: **Main Menu → Diagnostics → Manual Run**.
 6. Enable the **Manual Mode** control.
 7. Raise the valve position **above 30%** using the **+** (Plus) and **-** (Minus) controls.
 8. Set the Controller's **Enable/Disable** switch to **Enable**. The **READY** light should remain off and the unit should not start. If the unit does start, shut the unit off immediately and refer fault to qualified service personnel.
 9. Close the drain and pressure relief valve used in draining the unit.
 10. Open the water shut-off valve in the return piping to the unit.
 11. Open the water supply shut-off valve to the unit to refill.
 12. After the shell is full, press the **LOW WATER LEVEL – RESET** button to reset the low water cutoff.
 13. Press the **CLEAR** button to reset the **FAULT** LED and clear the displayed error message.
- Set the **Enable/Disable** switch to **Enable**. The unit is now ready for operation.

5.5 Water Temperature Fault Test

A high-water temperature fault is simulated using the **Automatic Reset Over-Temperature** switch.

1. Start the unit in the normal operating mode and allow the unit to stabilize at its setpoint.
2. On the Automatic Reset Over-Temperature switch, note the current setting, then:
 - a. Press the **Set** button two times, to activate a setting change.
 - b. Use the **Down** arrow to lower the setting to a temperature **below** the Outlet temperature displayed on the Controller’s front face (see Figure 5-5b).
 - c. Press the **Set** and **Down** arrow at the same time to save that temperature setting.

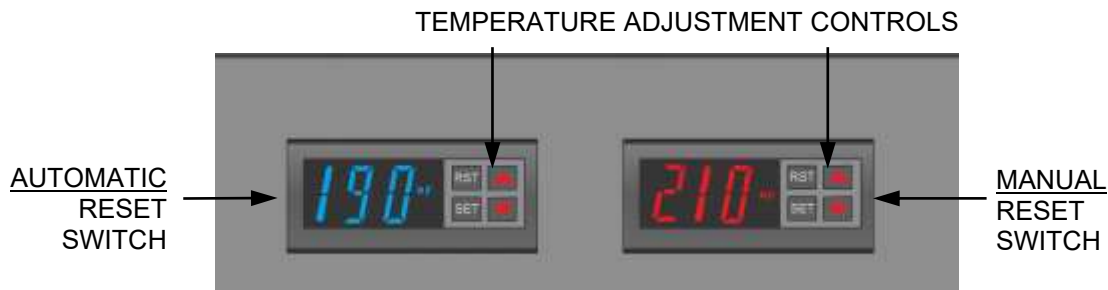

Figure 5-5a: Over Temperature Limit Switches

NOTE:

If the Controller’s is not configured to display outlet temperature, go to the **Main Menu → Advanced Setup → Unit → Front Panel Configuration** screen and set the **Upper-Right Display** parameter to **Water Outlet**.

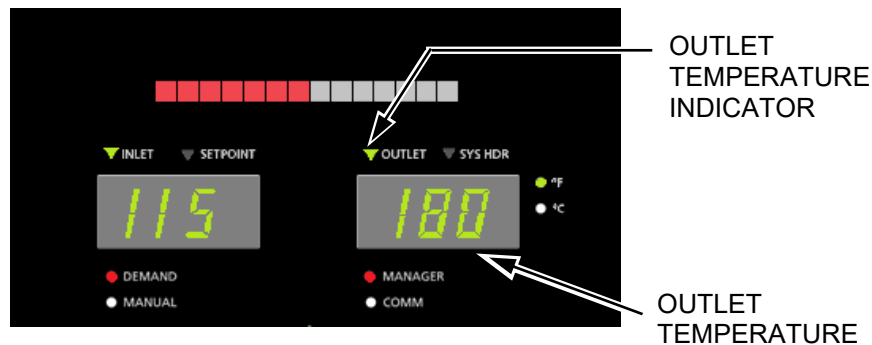

Figure 5-5b: Edge Controller Front Face

3. Once the Automatic Reset Over-Temperature switch setting is approximately just below the actual outlet water temperature, the unit should shut down, the **FAULT** indicator should start flashing, and a **High-Water Temp Switch Open** fault message should be displayed. It should not be possible to restart the unit.
4. Repeat Step 2 to return the Automatic Reset switch but press the **Up** arrow to it to its original setting.
5. The unit should start once the setting is above the actual outlet water temperature.
6. Repeat steps 1 – 4 on the Manual Reset switch. However, unlike the Automatic Reset switch, the unit will not restart automatically when the original temperature is restored. You must press the **RST** (Reset) button to restart the unit.

5.6 Interlock Tests

The unit is equipped with three interlock circuits, called the **Remote Interlock**, and **Delayed Interlock**. These circuits are connected to the I/O board's connector strip J6, labeled **Remote Interlock**, **Delayed Interlock 1** and **Delayed Interlock 2** (see Section 2.11.1: *I/O Board Connections* in the *Benchmark -Edge: INSTALLATION Manual* (OMM-0136)). These circuits can shut down the unit in the event an interlock is opened. These interlocks are shipped from the factory jumpered (closed). However, they may be utilized in the field as a remote stop and start, an emergency cut-off, or to prove that a device such as a pump, gas booster, or louver is operational.

5.6.1 Remote Interlock Test

1. Remove the I/O Box cover and locate the **Remote Interlock** terminals on connector strip J6.
2. On the Controller, go to: **Main Menu → Diagnostics → Manual Run**.
3. Enable the **Manual Mode** control.
4. Set the valve position **between 25% and 30%** using the + (Plus) and – (Minus) controls.
5. If there is a jumper across the **Remote Interlock** terminals, remove one side of the jumper. If the interlock is being controlled by an external device, either open the interlock via the external device or disconnect one of the wires leading to the external device.
6. The unit should shut down and the Controller should display **Interlock Open**.
7. Once the interlock connection is reconnected, the **Interlock Open** message should automatically clear, and the unit should restart.

5.6.2 Delayed Interlock Test

1. Remove the I/O Box cover and locate the **Delayed Interlock 1** terminals on connector strip J6.
2. On the Controller, go to: **Main Menu → Diagnostics → Manual Run**.
3. Enable the **Manual Mode** control.
4. Set the valve position between 25% and 30% using the + (Plus) and – (Minus) controls.
5. If there is a jumper across the **Delayed Interlock 1** terminals, remove one side of the jumper. If the interlock is connected to a proving switch of an external device, disconnect one of the wires leading to the proving switch.
6. The unit should shut down and display a **Delayed Interlock Open** fault message. The **FAULT** LED should be flashing.
7. Reconnect the wire or jumper removed in step 5 to restore the interlock.
8. Press the **CLEAR** button to reset the fault.
9. The unit should start.
10. Repeat the above for the **Delayed Interlock 2** terminals.

5.7 Flame Fault Test

Flame faults can occur during ignition or while the unit is already running. To simulate each of these fault conditions, proceed as follows:

1. Set the Controller's **Enable/Disable** switch to **Disable**.
2. On the Controller, go to: **Main Menu → Diagnostics → Manual Run**.
3. Enable the **Manual Mode** control.
4. Set the valve position **between 25% and 30%** using the **+** (Plus) and **-** (Minus) controls.
5. Close the gas train's Manual Shutoff valve located between the Safety Shut-Off Valve (SSOV) and the Air/Fuel Valve, as shown on Figure 5-3a to 5-3c, above.
6. It may be necessary to jump out the High Gas Pressure switch.
7. Set the Controller's **Enable/Disable** switch to **Enable** to start the unit.
8. The unit should purge and light the Pilot flame and then shut down after reaching the main Burner Ignition cycle and display **Flame Loss During Ign**.
9. Open the Manual Shutoff valve closed in step 5 and press the **CLEAR** soft key.
10. Restart the unit and allow it to prove flame.
11. Once flame is proven, close the Manual Shutoff valve located between the SSOV and the Air/Fuel Valve (see Figure 5-3a to 5-3c, above).
12. The unit should shut down and do one of the following:
 - a. **BMK750 – 2000 units**: the unit will execute an *IGNITION RETRY* cycle by performing the following steps:
 - The unit will execute a shutdown purge cycle for a period of 15 seconds and display **Wait Fault Purge**.
 - The unit will execute a 30 second re-ignition delay and display Wait Retry Pause.
 - The unit will then execute a standard ignition sequence and display Wait Ignition Retry.
 - Since the Manual Shutoff valve is still closed, the unit will fail the ignition retry sequence. Therefore, it will shut down and display Flame Loss During Ign following the IGNITION RETRY cycle.
 - b. **BMK2500 – 5000N units**: the unit will Lockout and **Flame Loss During Run** will flash in the display.
13. Open the manual gas valve closed in step 11.
14. Press the **CLEAR** button. The unit should restart and fire.

5.8 Air Flow Fault Tests-Blower Proof & Blocked Inlet Switches

These tests check the operation of the **Blower Proof** switch and **Blocked Inlet** switch shown in Figure 5-6a, 5-6b and 5-6c.

5.8.1 Blower Proof Switch Test

1. Set the Controller's **Enable/Disable** switch to **Disable**.
2. Depending on the model, remove the side and/or front panels to gain access to the Blower Proof Switch (see Figures above for location).
3. Use a Phillips head screw driver to remove the front cover from the switch to reveal the switch setting indicator dial (0.3 in the Figure below).

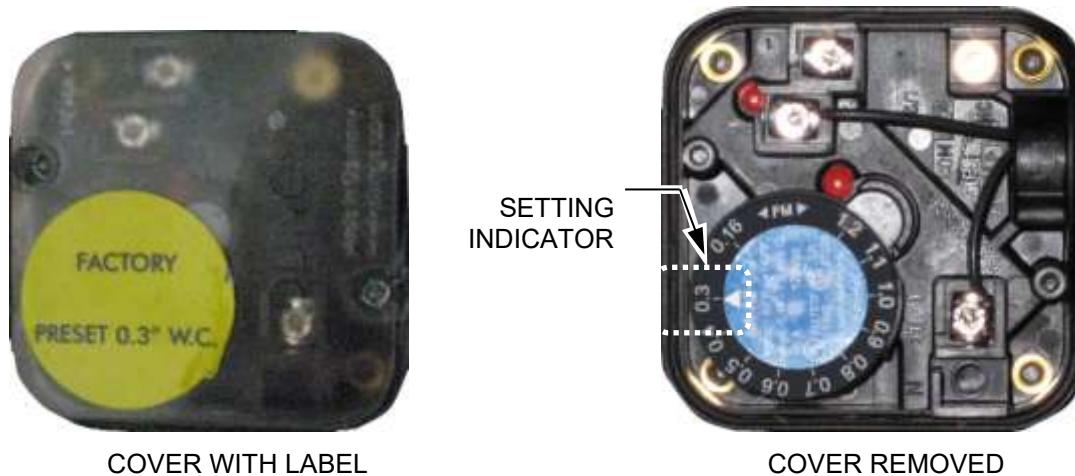

Figure 5-7: Blower Proof Switch

4. Set the Controller's **Enable/Disable** switch to **Enable** and wait for the boiler to go into the Purge sequence.
5. After about 5 seconds, with air flowing into the combustion chamber, slowly turn the dial clockwise (to higher value) until the unit trips off with an **Air Flow Fault During Purge** message. Optionally, you could attach a manometer and measure the setting at the trip point.
6. After the boiler shuts down, reset the dial indicator to its original position, shown on the switch cover label, then replace the switch cover.
7. Reset the boiler.

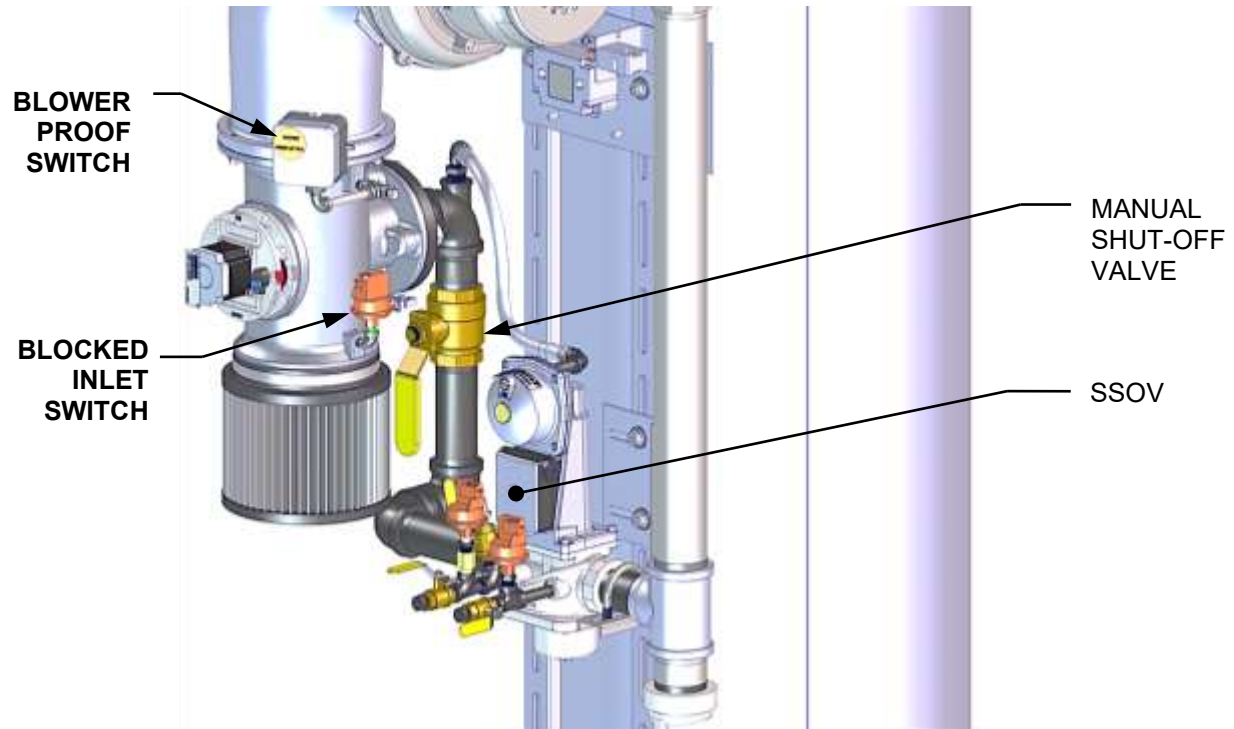

Figure 5-6a: Blower Proof & Blocked Inlet Switch Locations – BMK1500 – 5000N

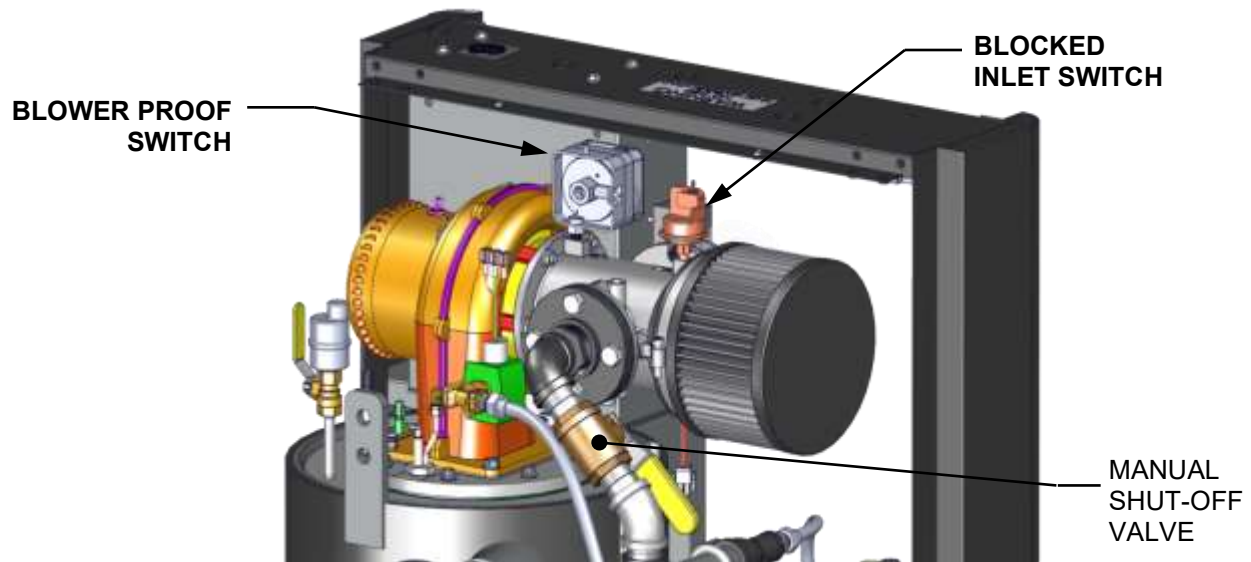

Figure 5-6b: Blower Proof & Blocked Inlet Switch Locations – BMK750 &1000

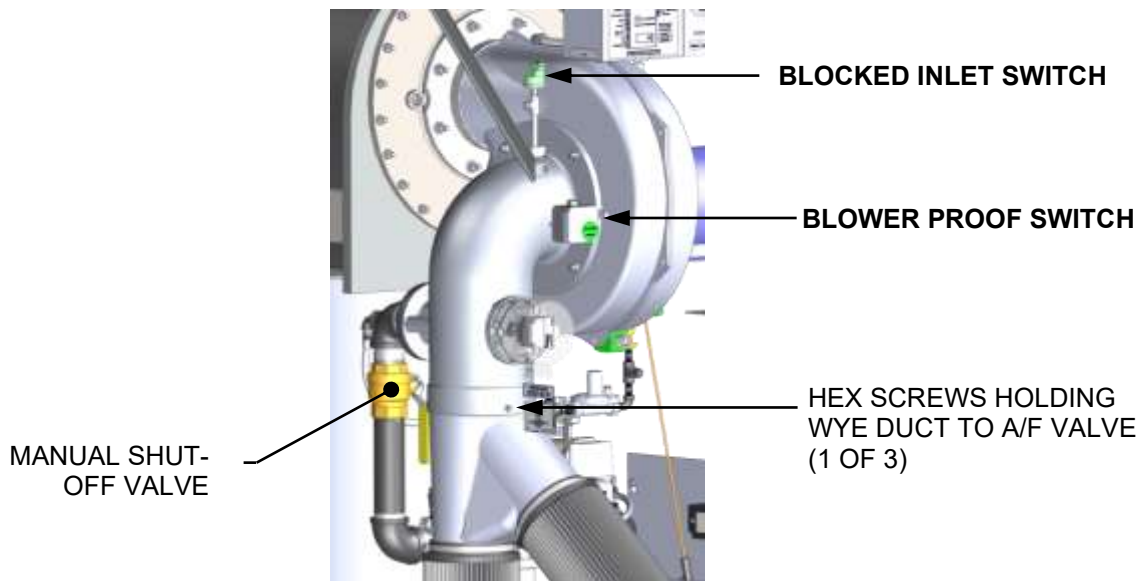

Figure 5-6c: Blower Proof & Blocked Inlet Switch Locations – BMK5000 & 6000

5.8.2 Blocked Inlet Switch Test

This test will be run in simulated fire mode, with the Blocked Inlet switch isolated from the rest of the control circuitry.

1. Set the Controller's **Enable/Disable** switch to **Disable**.
2. Remove the air filter(s) (see Figure 5-6a, 5-6b or 5-6c, above).

⚠ WARNING!

The blower suction is very strong and can pull nearby objects into the blower's fan blades. Do NOT allow anything to be pulled into the blower! Do not wear anything that could pull you into the blower.

3. Turn off the gas supply ball valve to the boiler and then complete the following steps:
 - a) Use jumper wires to jump out the Low Gas Pressure switch and the Blower Proof switch.
 - b) Remove the black connector boot from the Flame Detector.
 - c) Create a connector similar to the one shown below and connect it to the Flame Detector's black connector boot. Keep the alligator clip away from bare metal parts until step 4b.

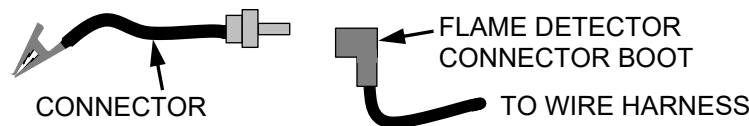

Figure 5-8: Connecting the Flame Signal Generator

4. On the Controller, go to: **Main Menu → Diagnostics → Manual Run** and then put the unit in **Manual Mode**, then complete the following:
 - a) Ramp the boiler up to 100% fire rate and then set the Controller's **Enable/Disable** switch to **Enable**.
 - b) When the Controller gets into the ignition phase, it will show **Ignition Trial**. At that point attach the alligator clip (see Figure 5-8) to any bare metal surface or ground. The Controller displays **Flame Proven** and begins to ramp up to 100% fire rate. Note that no gas or flame is present in the boiler at this time.
5. Wait for the boiler to ramp up to at least 90% before continuing.

6. Cover the combustion air inlet opening with a solid, flat object, such as a piece of thick plywood or a thick metal plate.
7. The unit should shut down and display **Airflow Fault During Run**. This step confirms proper operation of the Blocked Inlet switch.
8. Remove the cover from the air inlet opening and reinstall the Combustion Air Duct or air filter.
9. Remove the jumper wires installed in step 3 and replace the black connector boot on the Flame Detector.
10. Press the **CLEAR** button. The unit should restart.

5.9 SSOV Proof Of Closure Switch Check

The SSOV, shown in Figure 5-9, contains the **Proof of Closure** switch. The **Proof of Closure** switch circuit is checked as follows:

1. Set the Controller's **Enable/Disable** switch to **Disable**.
2. On the Controller, go to: **Main Menu → Diagnostics → Manual Run**, and then put the unit in **Manual Mode**.
3. Set the valve position **between 25% and 30%** using the + (Plus) and – (Minus) controls.
4. Remove the cover from the SSOV by loosening the screw shown in Figure 5-9. Lift off the cover to access the terminal wiring connections.
5. Disconnect wire #148 from the SSOV to “open” the Proof of Closure switch circuit.
6. The unit should fault and display **SSOV Switch Open**.
7. Replace wire #148 and press the **CLEAR** button.
8. Set the Controller's **Enable/Disable** switch to **Enable** to start the unit.
9. Remove the wire again when the unit reaches the purge cycle and **Purging** is displayed.
10. The unit should shut down and display **SSOV Fault During Purge**.
11. Replace the wire on the SSOV and press the **CLEAR** button. The unit should restart.



Figure 5-9: SSOV Actuator Cover Location

5.10 Purge Switch Open During Purge

The **Purge** switch (and **Ignition** switch) is located on the Air/Fuel Valve. To check the switch:

1. Set the Controller's **Enable/Disable** switch to **Disable**.
2. On the Controller, go to: **Main Menu → Diagnostics → Manual Run**, and then put the unit in **Manual Mode**.
3. Set the valve position **between 25% and 30%** using the **+** (Plus) and **-** (Minus) controls.
4. Remove the Air/Fuel Valve cover by rotating the cover counterclockwise to unlock (Figure 5-10).
5. Remove one of the two wires (#171 or #172) from the Purge switch (Figure 5-11a – 5-11c).
6. Set the Controller's **Enable/Disable** switch to **Enable** to start the unit.
7. The unit should begin its start sequence, then shut down and display **Prg Switch Open During Purge**.
8. Replace the wire on the Purge switch and press the **CLEAR** button. The unit should restart.

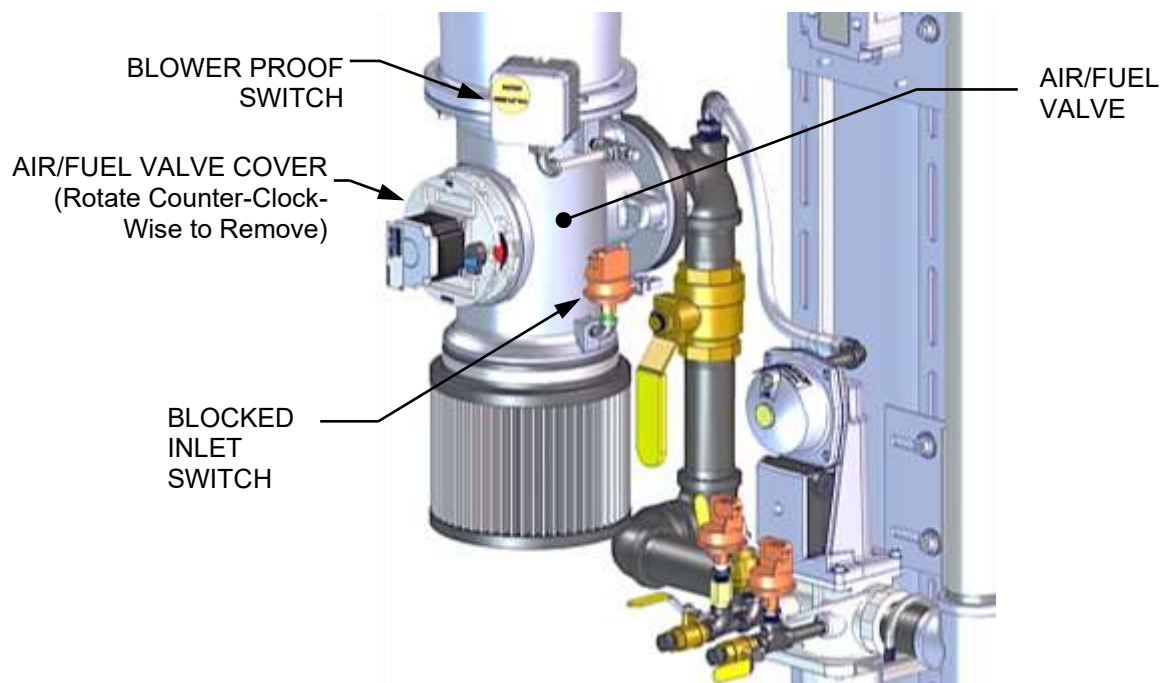

Figure 5-10: Air/Fuel Valve Cover Location – BMK1500 Shown

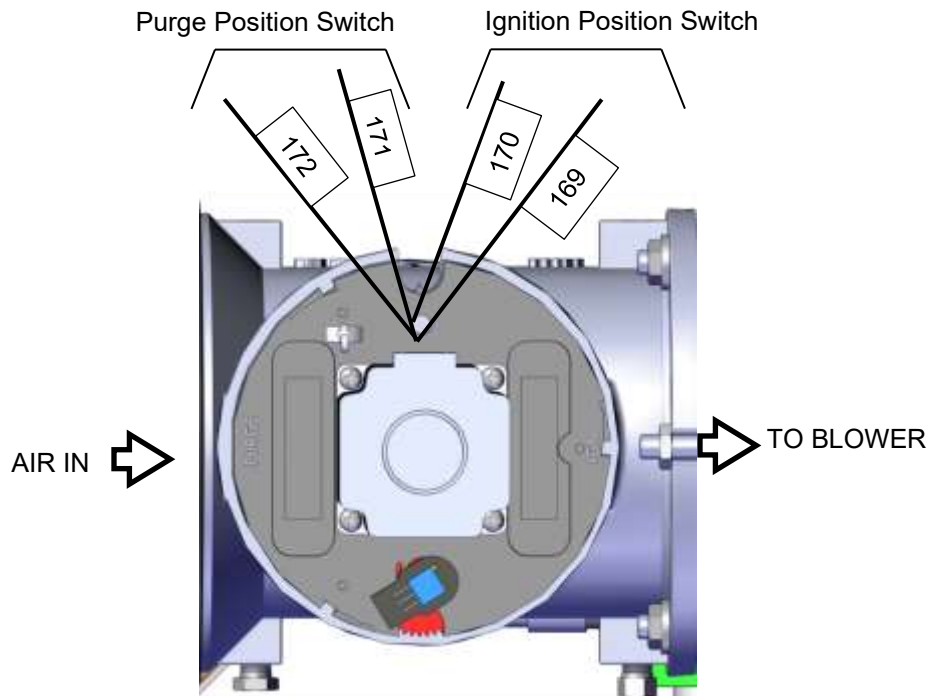

Figure 5-11a: Air/Fuel Purge and Ignition Locations – BMK750/1000

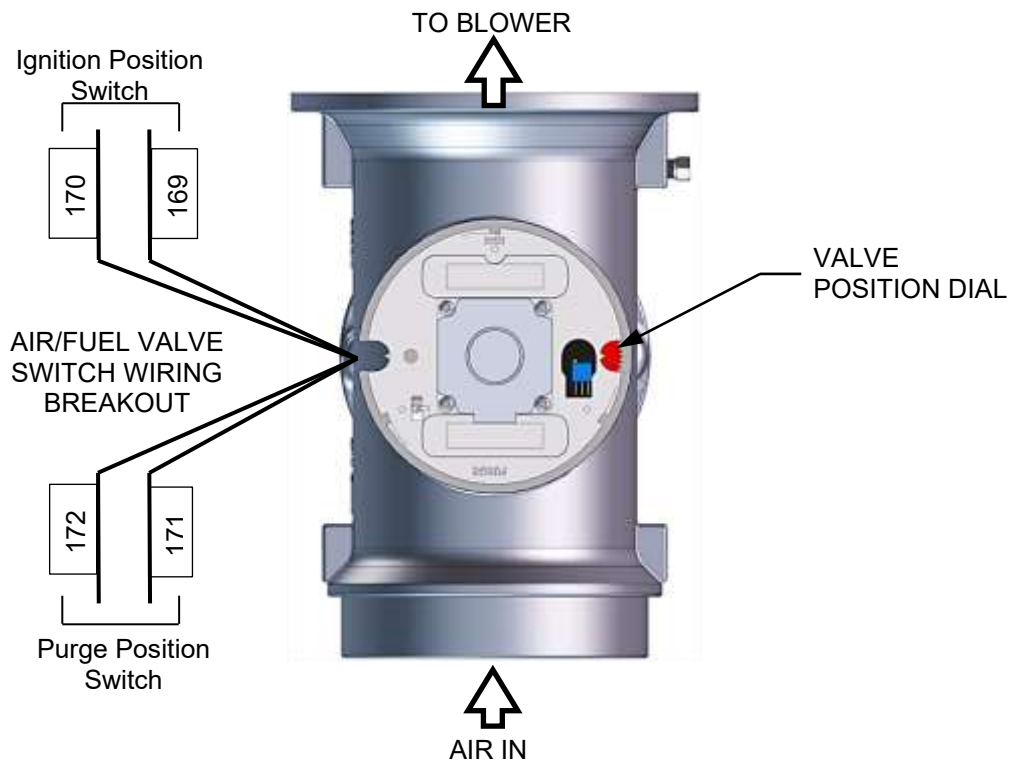

Figure 5-11b: Air/Fuel Purge and Ignition Locations – BMK1500 – 5000N

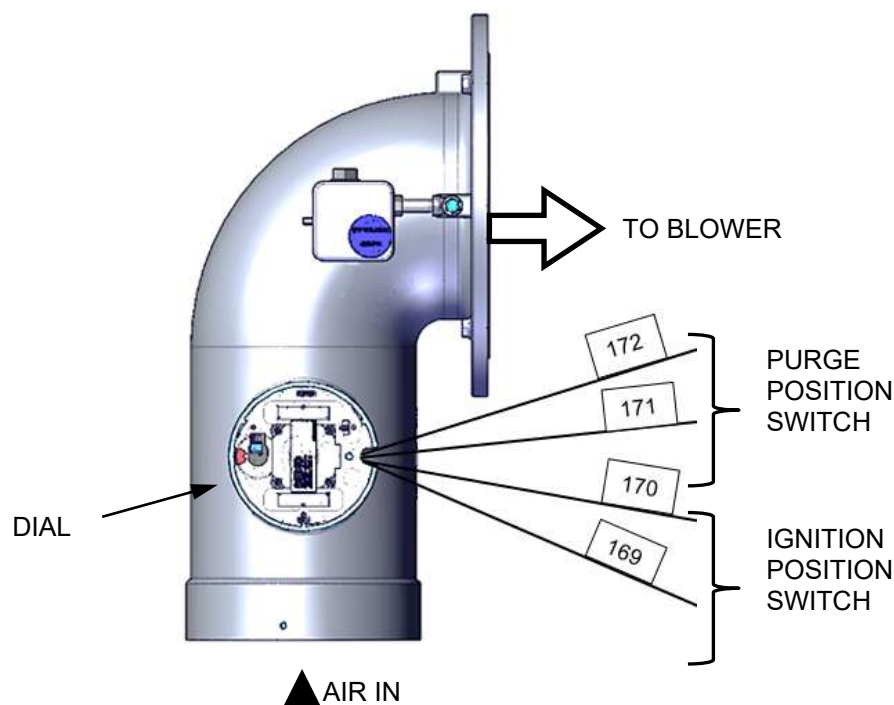

Figure 5-11c: Air/Fuel Purge and Ignition Locations – BMK5000 & 6000

5.11 Ignition Switch Open During Ignition

The **Ignition** switch (and the **Purge** switch) is located on the Air/Fuel Valve. To check the switch:

1. Set the Controller's **Enable/Disable** switch to **Disable**.
2. Go to **Main Menu →Diagnostics→ Manual Run** and then put the unit in **Manual Mode**.
3. Set the valve position **between 25% and 30%** using the + (Plus) and – (Minus) controls.
4. Remove the Air/Fuel Valve cover (Figure 5-10, above) by rotating the cover counterclockwise.
5. Remove one of the two wires (#169 or #170) from the Ignition switch (see Figure 5-11a – 5-11c, above).
6. Set the Controller's **Enable/Disable** switch to **Enable** to start the unit.
7. The unit should begin its start sequence and then shut down and display **Ign Switch Open During Ignition**.
8. Replace the wire on the Ignition switch and press the **CLEAR** button. The unit should restart.

5.12 Safety Pressure Relief Valve Test

Test the safety Pressure Relief Valve in accordance with ASME Boiler and Pressure Vessel Code, Section VI.

SECTION 6: STANDALONE MODES OF OPERATION

The descriptions and instructions in this chapter apply to **Standalone** units **only**; the unit cannot be a BST Client or BST Manager. For instructions on configuring BST modes of operation, see Chapter 7: *Boiler Sequencing Technology*, below.

Benchmark standalone boilers are capable of being operated in any one of six different modes. The following sections provide descriptions of each of these operating modes. All temperature related parameters are at their factory default values, which work well in most applications. However, it may be necessary to change certain parameters to customize the unit to the system environment. After reading this section, parameters can be customized to suit the needs of the specific application.

6.1 Outdoor Reset Mode

The **Outdoor Reset** mode of operation is based on outside air temperatures. As the outside air temperature decreases, the supply header temperature will increase and vice versa. For this mode, it is necessary to install an outside air sensor.

6.1.1 Outdoor Air Temperature Sensor Installation

The outdoor air temperature sensor must be mounted on the North side of the building in an area where the average outside air temperature is expected. The sensor must be shielded from the sun's direct rays, as well as direct impingement by the elements. If a cover or shield is used, it must allow free air circulation. The sensor may be mounted **up to 200 feet (61m)** from the unit. connections are made at the Input/Output (I/O) Box on the front of the boiler.

The Outdoor Air Temp Sensor must be connected to the I/O board strip J3, terminals 1 (labeled *Outside Temp +*) and 2 (*Outside Temp -*). Use shielded 18 to 22 AWG wire for connections.

For additional information see Section 2.11.1 in *Benchmark -Edge: INSTALLATION Manual* (OMM-0136).

6.1.2 Outdoor Reset Mode Startup

Startup in the **Outdoor Reset** mode is accomplished as follows:

NOTE: It is required to have an outdoor sensor for the Outdoor reset. A header sensor or boiler supply sensor can be used depending on the plant configuration.

1. As a prerequisite, verify that the unit is **not** a BST Client or Manager. Go to: **Main Menu → Advanced Setup → BST Cascade → Cascade Configuration, Unit Mode = Off.**
2. On the Controller, go to: **Main Menu → Advanced Setup → Unit → Application Configuration.**
3. In the **SH Operating Mode** parameter, choose **Outdoor Reset**. The parameters that appear will be used to create a temperature curve to vary the unit's active setpoint depending on the Outside Air Temperature (OAT).



Figure 6-1: Application Configuration Screen

4. Set the following parameters to define the total outside air temperature span which will be used for Setpoint control.
 - **OAR Min Outside Temp:** The minimum outside temperature the system can read; it is tied to the OAR Max Setpoint. For example, if OAR Min Outside Temp is -5°F and OAR Max Setpoint is 180°F, when the outside temperature is -5°F or below, the system will supply 180°F.
 - **OAR Max Outside Temp:** Outdoor Air Reset Maximum Outside Temperature that the system will operate to. For example: if set to 60°F, the boiler will operate between 60°F outside temperature and OAR Min Outside Temp setting.
5. Set the following parameters to define the Setpoint curve, which will be used to yield a desired setpoint for a given outside temperature:
 - **OAR Max Setpoint:** The maximum allowable setpoint (range = Min Setpoint up to 210°F (98.9°C)).
 - **OAR Min Setpoint:** The minimum allowable setpoint (range = 40°F (4.4°C) up to the Max Setpoint).
6. Set the **Warm Weather Shutdown** parameter to the threshold outside temperature above which the unit shuts down. For example, if set to 65°F, when the outside temperature goes above 65°F, the unit goes into standby. The unit will then restart when temperature falls below 60°F.

6.2 Constant Setpoint Mode

The **Constant Setpoint** mode (the default) is used when a fixed header temperature is desired. Common uses of this mode of operation include water source heat pump loops, and indirect heat exchangers for potable hot water systems or processes.

No external sensors are required to operate in this mode. While it is necessary to set the desired setpoint temperature, it is not necessary to change any other temperature-related functions. The unit is factory preset with settings that work well in most applications. Prior to changing any temperature-related parameters, other than the setpoint, it is suggested that an AERCO representative be contacted.

The setpoint temperature of the unit is adjustable from 40°F to 245°F (4.4°C to 118.3°C).

To set the unit to **Constant Setpoint** mode:

1. As a prerequisite, verify that the unit is **not** a BST Client or Manager. Go to: **Main Menu → Advanced Setup → BST Cascade → Cascade Configuration, Unit Mode = Off.**
2. On the Controller, go to: **Main Menu → Advanced Setup → Unit → Application Configuration.**
3. Press **SH Operating Mode** and choose **Constant Setpt.**
4. Press **SH Setpoint** and choose the desired setpoint.

6.3 Remote Setpoint Mode

The unit's setpoint can be remotely controlled by an Energy Management System (EMS) or Building Automation System (BAS). The **Remote Setpoint** can be driven by a current or voltage signal.

NOTE: See Section 2.11.1: *Remote Setpoint Field Wiring* in the *Benchmark -Edge: INSTALLATION Manual* (OMM-0136) for field wiring instructions.

When using the **Remote Setpoint** mode default setting, **4 - 20 mA/1 - 5 VDC**, a 4 to 20 mA/1 to 5 VDC signal, sent by an EMS or BAS, is used to change the unit's setpoint. The **4 mA/1V** signal is equal to Setpoint Low Limit, while a **20 mA /5V** signal is equal to a Setpoint High Limit setpoint. When a **0 to 20 mA/0 to 5 VDC** signal is used, **0 mA** is equal to Setpoint Low Limit.

In addition to the current and voltage signals described above, the **Remote Setpoint** mode can also be driven by a RS-485 Modbus Network signal from an EMS or BAS.

The **Remote Setpoint** mode of operation can be used to drive single as well as multiple units.

NOTE: If voltage, rather than current signal is used to control the remote setpoint, a DIP switch adjustment must be made on the PMC Board located in the Edge Controller. Contact your local AERCO representative for details.

To set the unit to **Remote Setpoint** mode:

1. As a prerequisite, verify that the unit is **not** a BST Client or Manager. Go to: **Main Menu → Advanced Setup → BST Cascade → Cascade Configuration, Unit Mode = Off.**
2. On the Controller, go to **Main Menu → Advanced Setup → Unit → Application Configuration.**
3. Press **SH Operating Mode** and choose **Remote Setpt.**
4. Set the **Remote Setpoint** parameter to one of the following: **4-20mA/1-5V, BST (PWM) Input, BAS, 0-20mA/0-5V** or **Network.**

If the **Network** setting is selected for RS-485 Modbus operation, a valid Comm Address must be entered in the *Setup* menu. Refer to the *Modbus Communication Manual* (OMM-0035) for information.

While it is possible to change the values of temperature related functions, the unit is factory preset with values that work well in most applications. It is suggested that an AERCO representative be contacted, prior to changing any temperature-related function values.

6.4 Direct Drive Modes

The unit's air/fuel valve position (% open) can be changed by a remote signal which is typically sent from an Energy Management System (EMS) or from a Building Automation System (BAS). The **Direct Drive** mode can be driven by a current or voltage signal.

The default setting for the **Direct Drive** mode is **4-20 mA/1-5 VDC**. With this setting, a 4 to 20 mA signal, sent by an EMS or BAS is used to change the unit's valve position from 0% to 100%. A **4 mA/1V** signal is equal to a **0%** valve position, while a **20 mA /5V** signal is equal to a **100%** valve position. When a **0-20 mA/0-5 VDC** signal is used, **zero** is equal to a **0%** valve position.

In addition to the current and voltage signals described above, the **Direct Drive** mode can also be driven by a RS-485 Modbus Network signal from an EMS or BAS. When in **Direct Drive** mode, the unit is a slave to the EMS or BAS and does not have a role in temperature control. **Direct Drive** can be used to drive single, or multiple units.

NOTE: If voltage rather than current signal is used to control the remote setpoint, a DIP switch adjustment must be made on the CPU Board located in the Edge Controller. Contact your local AERCO representative for details.

To enable the **Direct Drive** mode:

1. As a prerequisite, verify that the unit is **not** a BST Client or Manager. Go to: **Main Menu → Advanced Setup → BST Cascade → Cascade Configuration, Unit Mode = Off**.
2. On the Controller, go to: **Main Menu → Advanced Setup → Unit → Application Configuration**.
3. Press **SH Operating Mode** parameter and choose **Direct Drive**.
5. The **Remote Signal** parameter now appears. It can be set to one of the following: **4-20mA/1-5V, BST (PWM) Input, BAS, 0-20mA/0-5V** or **Network**
4. If **Network** was selected in the previous step, the **Unit Address** parameter appears. Enter a valid Comm address in this parameter.

Refer to *Modbus Communication Manual* (OMM-0035) for additional information.

6.5 AERCO Control System (ACS)

NOTE: ACS is for installations with between 17 and 32 boilers. It utilizes only RS-485 signaling to the boiler. For installations with 1 to 16 boilers Boiler Sequencing Technology (BST) is recommended. See Section 7: *Boiler Sequencing Technology*.

The **ACS** mode of operation is used in conjunction with an AERCO Control System. The **ACS** mode is used when it is desired to operate multiple units in the most efficient manner possible. For this mode of operation, an ACS Header Temp Sensor must be installed **between 2 and 10 feet (0.61 and 3m)** downstream of the **last** boiler in the boiler plant's supply water header.

ACS can control up to 32 boilers via Modbus (RS-485) network communication.

For ACS programming, operation, and Header Temp Sensor installation details, see the *ACS Operations Guide* (OMM-081). For operation via an RS-485 Modbus network, refer to *Modbus Communication Manual* (OMM-0035).

To enable the **ACS** mode:

1. As a prerequisite, verify that the unit is **not** a BST Client or Manager. Go to: **Main Menu → Advanced Setup → BST Cascade → Cascade Configuration, Unit Mode = Off.**
2. On the Controller, go to: **Main Menu → Advanced Setup → Unit → Application Configuration.**
3. Press **SH Operating Mode** parameter and choose **Direct Drive.**
4. Press the **Remote Signal** parameter and choose **Network.**
5. Press the **Baud Rate** parameter and choose **9600.**

NOTE: See the *Benchmark -Edge: INSTALLATION Manual* (OMM-0136) for field wiring instructions.

6.6 Combination Control System (CCS)

NOTE: The ACS can be utilized for any Combination Control System in a plant larger than 16 units.

A Combination Control System (CCS) is one that uses multiple boilers to cover both space-heating and domestic hot water needs. The theory behind this type of system is that the maximum space-heating load and the maximum domestic hot water load do not occur simultaneously. Therefore, boilers used for domestic hot water are capable of switching between constant setpoint and ACS control.

For a typical CCS, an adequate number of boilers are installed to cover the space-heating load on the design-day. However, one or more units are used for the domestic hot water load as well. These boilers are combination units and are referred to as the combo boilers. The combo boilers heat water to a constant setpoint temperature. That water is then circulated through a heat exchanger in a domestic hot water storage tank.

Only the AERCO Control System (ACS) is necessary to configure this system if only a single valve is used to switch from space heating to domestic hot water. However, the ACS Relay Panel is required in combination with the ACS when there are up to two isolation valves, boiler interlocks, and/or a Domestic Hot Water (DHW) pump in a Combination heating plant where AERCO boilers are being used for both Building Heat and Domestic Hot Water heating.

The following two options are available for using a combination system; one that uses only the ACS, and one that requires the optional ACS Relay Box:

- **OPTION 1** - This option is selected when the ACS controls a boiler plant containing up to eight combination boilers that are Domestic Hot Water Priority (DHW PRIORITY) boilers, along with building heat (BLDG HEAT) boilers, and *one* hydronic isolation valve in the main header between the BLDG HEAT boilers and the DHW PRIORITY boilers.
- **OPTION 2** – When this option is selected, the ACS Relay Panel must be used in conjunction with the ACS. For this option, the ACS controls a boiler plant containing up to eight combination boilers that are divided up into Building Priority (BLDG PRIORITY) boilers and Domestic Hot Water Priority (DHW PRIORITY) boilers, along with building heat (BLDG HEAT) boilers, and using *two* hydronic isolation valves in the main header, one between the BLDG HEAT and BLDG PRIORITY boilers, and the other between the BLDG PRIORITY and the DHW PRIORITY boilers.

In Option 2, when the space-heating load is such that when all the space-heating boilers are at the 100% valve position, the ACS will then ask the ACS Relay Box for the domestic boilers to become space-heating boilers. Provided the domestic hot water load is satisfied, the combo (hot water) boilers will then become space-heating boilers. If the domestic hot water load is not satisfied, the combo boiler(s) remain on the domestic hot water load. If the combo boilers switch over to space heating, but there is a call for domestic hot water, the ACS Relay Box switches the combo units back to the domestic load. The

ACS in combination with the ACS Relay Box will ask the BLDG PRIORITY boilers to help with domestic hot water heating if the DHW PRIORITY boilers are not able to satisfy the domestic hot water demand.

When the combo units are satisfying the domestic load, they are in the **Constant Setpoint** mode of operation. When the combo units switch over to space heating, their mode of operation changes to follow the ACS command. For more information concerning the operation of the ACS, consult the *AERCO Control System Manual* (OMM-0081); for information on mounting and wiring the ACS Relay Box, see section 2.14 in that manual.

6.6.1 Combination Control System Field Wiring

Wiring for this system is between the ACS, the ACS Relay Box, and the terminals in the I/O Box. Wire the units using a shielded twisted pair of 18 to 22 AWG wire. When wiring multiple units, each unit's wiring must conform to the above.

6.6.2 Combination Control System Setup and Startup

To setup a boiler for **Combination** mode:

1. As a prerequisite, verify that the unit is ***not*** a BST Client or Manager. Go to: **Main Menu → Advanced Setup → BST Cascade → Cascade Configuration, Unit Mode = Off.**
2. On the Controller, go to: **Main Menu → Advanced Setup → Unit → Application Configuration.**
3. Press **SH Operating Mode** and choose **Combination**.
4. Press the **Remote Signal** parameter and choose **Network**.

While it is possible to change other temperature-related functions for **Combination** mode, these functions are preset at the factory. These default settings work well in most applications. It is suggested that AERCO be contacted prior to changing settings other than the unit's setpoint.

SECTION 7: BOILER SEQUENCING TECHNOLOGY

7.1 Introduction

The Boiler Sequencing Technology system (BST) is an integrated 16 boiler control system. It is built into the Edge Controller. It has its own sophisticated PID control system designed to simultaneously control the light off and modulation of **up to 16 boilers** while achieving maximum operational efficiency.

BST is designed to ensure that all Boilers in the system operate at maximum efficiency. This is accomplished by lighting off boilers only when all ignited boilers reach or exceed a defined Valve Position (Fire Rate). Operating all boilers below the defined Fire Rate “Next on VP” (for Next Turn on Valve Position) ensures that they are firing at their most efficient Fire Rate. One unit the BST network is defined as the “Manager” and all other units on the network are defined as “Client” units. The Manager monitors the system Header Temperature, and also monitors all Client unit’s status information, efficiently controlling all units in order to achieve and maintain the required BST Setpoint Temperature.

When there is a demand, the Manager will light off the lead boiler based on the BST Sequencing selection in the *BST Cascade Status* screen. As system load increases and the valve position of the ignited unit(s) reaches the Next on VP (% valve position), the Manager will light off the next available unit. A simplified block diagram of multiple Boilers connected to a BST is shown in Figure 7-1 below.

NOTE: Use either FFWD Header Temp Sensor or Modbus Header Temp Sensor.

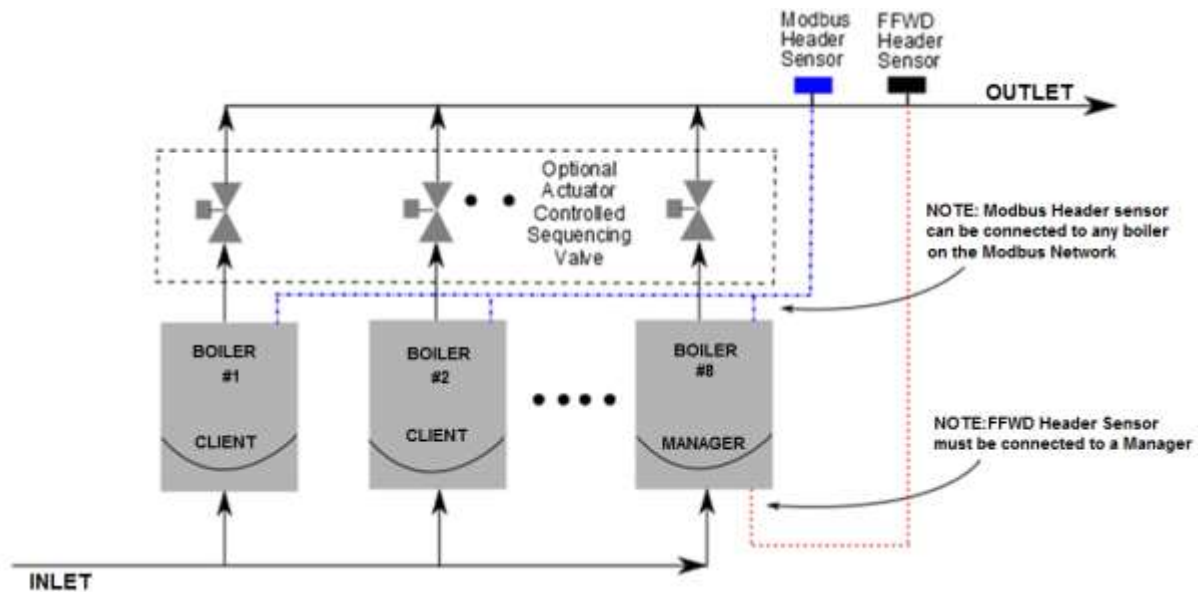

Figure 7-1: Simplified BST Block Diagram

NOTE: After the boiler load is satisfied, the isolation valve remains open for a programmed interval (default = 2 minutes) before closing. When the *system load* is satisfied, the Edge Controller will open the isolation valves for all the boilers. The BST controls the valves via a 0-20 mA signal (see Section 2.11.1: *I/O Board Connections* in the *Benchmark -Edge: INSTALLATION Manual* (OMM-0136)).

7.1.1 Installation Notes

A ProtoNode is needed for all protocols on BMK. If your installation includes a ProtoNode SSD (Client-Client Device), you **must** adhere to the procedure listed below. Failure to complete these steps can result in the failure of the BST system.

- a) Do **NOT** install the ProtoNode device at the outset of the installation. If the ProtoNode device is already installed, you must physically disconnect it from the Modbus network on the I/O board.
- b) Make sure that the Modbus load and bias resistors are properly configured for the system to operate without the ProtoNode installed.
- c) Temporarily set the BST system for **Constant Setpoint** mode of operation (see below).
- d) Turn on and completely test the installation to verify that it is operating properly.
- e) Once the installation is working properly as a BST system, install the ProtoNode device.
- f) Make sure that the Modbus load and bias resistors are properly configured for the system to operate with the ProtoNode installed.
- g) Set the BST system for desired mode of operation (**Setpoint** mode).
- h) Test the system completely with the ProtoNode installed.

The BST setup options are:

1. Constant Setpoint
2. Remote Setpoint, which includes two options:
 - Analog Input (4-20mA, 0-20mA, 1-5V, or 0-5V)
 - BAS Mode (Network or BAS)
3. Outdoor Air Temperature Reset.

7.2 BST Implementation Instruction

The instructions below refer to I/O board connections on the Benchmark boilers, as described in Section 2.11.1 of *Benchmark -Edge: INSTALLATION Manual* (OMM-0136).

The instructions in the sections below refer to one or more of the following components:

- Header Temp Sensor P/N **61058 (PT1000)** dual bead
- Outdoor Sensor P/N **61060 (PT1000)**

The wiring diagram below applies to the setup instructions in the next three sections.

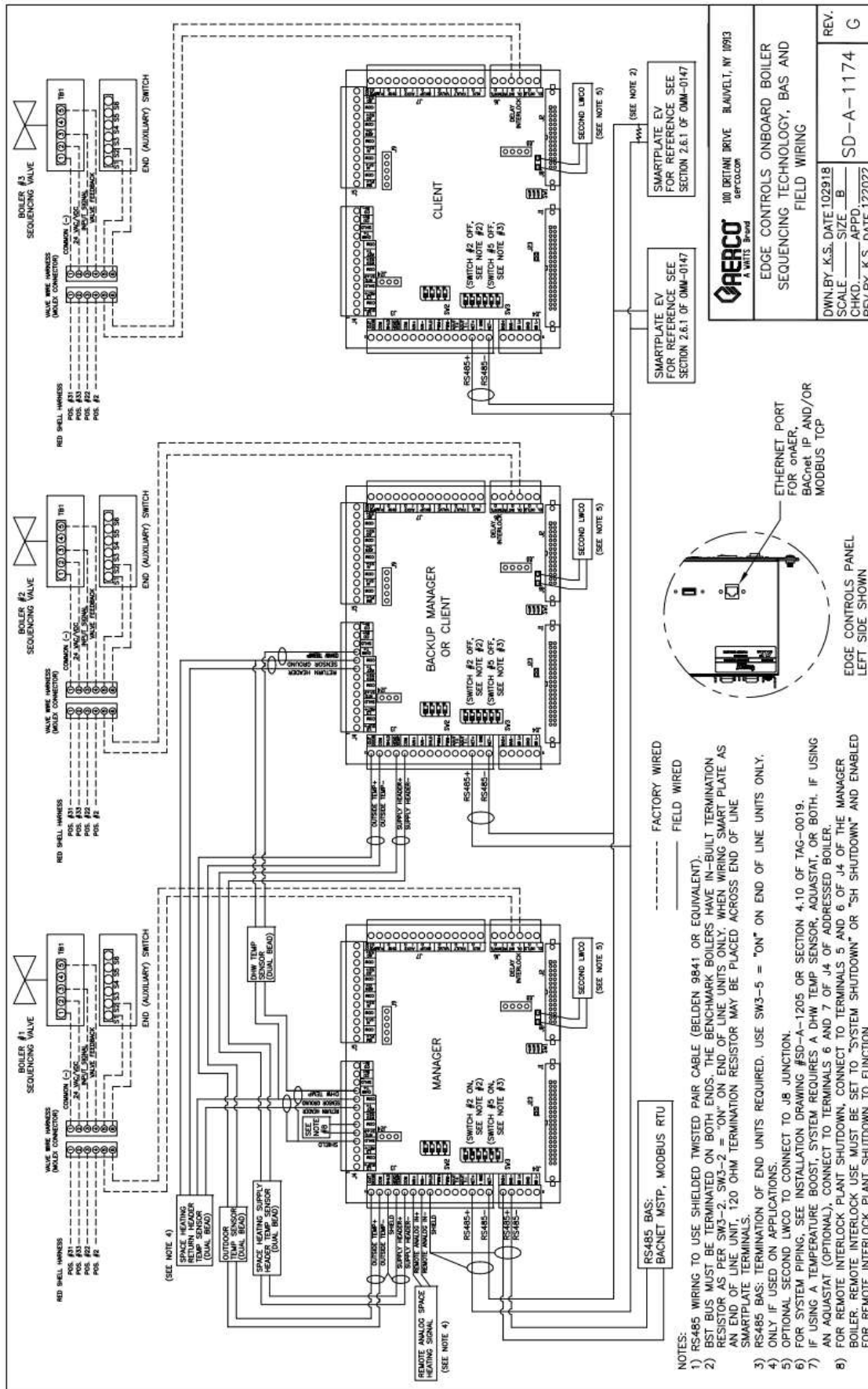

Figure 7-2: BST, BAS and Field Wiring – SD-A-1174

7.2.1 BST Setup: Constant Setpoint

Complete the instructions below to configure the Controller for **Constant Setpoint**.

1. Go to: **Main Menu → EZ Setup**.
2. On the **Select Configuration** screen press **BST Cascade**.
3. On the **Cascade Role** screen select **BST Manager** then press **Next**.
4. The next screen displays the current time and date. Press **Next** to continue or press either field and enter the correct time or date.
5. On the **Cascade Communication** screen, fill in the settings that appear.
 - **Unit Address:** The unique communication address of the current (Manager) unit. (Range: 1 to 127)
 - **Min & Max Address:** The address range in the BST cascade, 1 up to the total number of units in the cascade; for example, 1 and 10. (**Max Address** maximum = 16).
 - **SSD Address:** The Client/Client Device address. This parameter is for backwards compatibility with the C-More Control system.
 - **Cascade Baud Rate:** Select the rate at which information is transferred in a communication channel: 9600, 19200, 38400, or 115200 bits per second.
 - **Plant Failsafe Mode:** The Manager's operating mode if there is a loss of communication between the Manager and Client units, or to the BAS or external signal/sensor, such as an outdoor sensor (default = **Constant Setpoint**).
 - **Plant Failsafe Setpoint** (only if **Plant Failsafe Mode** = **Constant Setpoint**): Specify the Setpoint for all units in the cascade.
6. The **Client Address** screen appears as a reminder to set up all Client units in the BST Cascade before continuing. Once all Client units are set up, press **Next** to continue.
7. The **Unit Address** screen shows a grid with a color-coded square representing each unit discovered in the cascade and a code indicating its current status. Before continuing, verify that this screen confirms your understanding of the state of all units in the cascade. **IMPORTANT: Do not continue past this screen unless it accurately represents the cascade you are creating.**
8. When the **Select Your Boiler Application** screen appears, chose **Space Heating**.
9. On the **SH Operating Mode** screen choose **Constant Setpoint**.
10. Specify the **SH Setpoint**. Pressing **Next** takes you to the **Select BAS Mode** screen.
11. If the unit communicates with the site's BAS (Building Automation System), the **Select BAS Mode** screen appears. Choose the communication protocol it will use, or else press **Off**.
12. Fill in the parameters to establish communications with BAS via the option you selected.
13. Once the setup has been configured, the **EZ Setup Complete** screen displays a summary of the completed setup as verification that the setup is complete and saved.

7.2.2 BST Setup: Remote Setpoint

Complete the instructions below to configure the Controller for **Remote Setpoint**.

1. Go to: **Main Menu → EZ Setup**.
2. On the **Select Configuration** screen press **BST Cascade**.
3. On the **Cascade Role** screen select **BST Manager** then press **Next**.
4. The next screen displays the current time and date. Press **Next** to continue or press either field and enter the correct time or date.
5. On the **Cascade Communication** screen, fill in the settings that appear.
 - **Unit Address:** The unique communication address of the current (Manager) unit. (Range: 1 to 127)
 - **Min & Max Address:** The address range in the BST cascade, 1 up to the total number of units in the cascade; for example, 1 and 10 (**Max Address** maximum = 16).
 - **SSD Address:** The Client/Client Device address. This parameter is for backwards compatibility with the C-More Control system.
 - **Cascade Baud Rate:** Select the rate at which information is transferred in a communication channel: **9600**, **19200**, **38400** or **115200** bits per second.
 - **Plant Failsafe Mode:** The Manager's operating mode if there is a loss of communication between the Manager and Client units, or to the BAS or external signal/sensor, such as an outdoor sensor (default = **Constant Setpoint**).
 - **Plant Failsafe Setpoint** (only if **Plant Failsafe Mode = Constant Setpoint**): Specify the Setpoint for all units in the cascade.
6. The **Client Address** screen appears as a reminder to set up all Client units in the BST Cascade before continuing. Once all Client units are set up, press **Next** to continue.
7. The **Unit Address** screen shows a grid with a color-coded square representing each unit discovered in the cascade and a code indicating its current status. Before continuing, verify that this screen confirms your understanding of the state of all units in the cascade. **IMPORTANT: Do not continue past this screen unless it accurately represents the cascade you are creating.**
8. When the **Select Your Boiler Application** screen appears, choose **Space Heating**.
9. The **SH Operating Mode** screen now appears; choose **Remote Setpoint**.
10. The **Select Remote Setpoint Type** screen appears. Choose how the unit will access the setpoint.
 - A. If you chose **4-20mA**, **0-20mA**, **1-5V**, or **0-5V**, the **SH Analog Input** screen appears. Enter the upper and lower limits of the SH setpoint in the **BST SH Setpt Low Limit** and **BST SH Setpt High Limit** fields.
 - B. If you chose **Network**, the **Select COM Settings** screen appears. Enter the **Unit Address** and **Unit Baud Rate**.
 - C. If you chose either **BAS** or **PWM**, the **Select BAS Mode** screen appears (see next step).
14. If the unit communicates with the site's BAS (Building Automation System), the **Select BAS Mode** screen appears. Choose the communication protocol it will use, or press **Off**.
15. Fill in the parameters to establish communications with BAS via the option you selected.
16. Once the setup has been configured, the **EZ Setup Complete** screen displays a summary of the completed setup as verification that the setup is complete and saved.

7.2.3 BST Setup: Outdoor Air Temperature Reset

Complete the instructions below to configure the Controller for **Outdoor Air Temp Reset**.

NOTE: If the outdoor air sensor is not connected, **Outdoor Air Temperature Reset** is disabled.

1. Go to: **Main Menu → EZ Setup**.
2. On the **Select Configuration** screen press **BST Cascade**.
3. On the **Cascade Role** screen select **BST Manager** then press **Next**.
4. The next screen displays the current time and date. Press **Next** to continue or press either field and enter the correct time or date.
5. On the **Cascade Communication** screen, fill in the settings that appear.
 - **Unit Address:** The unique communication address of the current (Manager) unit. (Range: 1 to 127)
 - **Min & Max Address:** The address range in the BST cascade, **1** up to the total number of units in the cascade; for example, **1** and **10** (**Max Address** maximum = **16**).
 - **SSD Address:** The Client/Client Device address. This parameter is for backwards compatibility with the C-More Control system.
 - **Cascade Baud Rate:** Select the rate at which information is transferred in a communication channel: **9600**, **19200**, **38400** or **115200** bits per second.
 - **Plant Failsafe Mode:** The Manager's operating mode if there is a loss of communication between the Manager and Client units, or to the BAS or external signal/sensor, such as an outdoor sensor (default = **Constant Setpoint**).
 - **Plant Failsafe Setpoint** (only if **Plant Failsafe Mode = Constant Setpoint**): Specify the Setpoint for all units in the cascade.
6. The **Client Address** screen appears as a reminder to setup all Client units in the BST Cascade before continuing. Once all Client units are set up, press **Next** to continue.
7. The **Unit Address** screen shows a grid with a color-coded square representing each unit discovered in the cascade and a code indicating its current status. Before continuing, verify that this screen confirms your understanding of the state of all units in the cascade. **IMPORTANT: Do not continue past this screen unless it accurately represents the cascade you are creating.**
8. When the **Select Your Boiler Application** screen appears, choose **Space Heating**.
9. The **SH Operating Mode** screen now appears; choose **Outdoor Air Temperature Reset**.
10. The **Space Heating Outdoor Reset** screen appears. Specify the minimum and maximum inside and outside temperatures that will be used to create the associated OATR curve that trigger the unit to turn on and off, and in **Warm Weather Shutdown** specify the threshold outside temperature above which the unit shuts down.
17. If the unit communicates with the site's BAS (Building Automation System), the **Select BAS Mode** screen appears. Choose the communication protocol it will use, or else press **Off**.
18. Fill in the parameters to establish communications with BAS via the option you selected.
19. Once the setup has been configured, the **EZ Setup Complete** screen displays a summary of the completed setup as verification that the setup is complete and saved.

SECTION 8: MAINTENANCE

8.1 Maintenance Schedule

For maximum efficiency and reliability, the following routine maintenance procedures should be performed in the time periods specified. For a complete inspection check list see ASME CSD-1 chart.

⚠ WARNING!

- Follow all Lockout/Tagout protocols in effect at the site.
- Disconnect the AC power supply by turning off the service switch and AC supply circuit breaker.
- Shut off the gas supply at the manual shut-off valve provided with the unit.
- Allow the unit to cool to a safe water temperature to prevent burning or scalding.

SEC	ITEM	6 MOS. *	12 MOS.	24 MOS.	LABOR TIME
8.2	Igniter-Injector (BMK750 – 5000N only)	Inspect	Inspect/replace	Replace	15 mins.
8.2.1	Pilot Burner (BMK5000 & 6000 only)	Inspect	Inspect/replace	Replace	15 mins.
8.3	Flame Detector	Inspect	Inspect/replace	Replace	15 mins.
8.4	O ₂ Sensor	Inspect	Inspect/clean		15 mins.
4.4	Combustion Calibration	Check	Check		1 hr.
8.5	Test Safety Devices		See ASME CSD-1 Chart		45 mins.
8.6	Burner			Inspect	2 hrs.
8.8	Condensate Drain Trap	Inspect	Inspect/clean/ replace gaskets	Inspect/clean/ replace gaskets	30 mins.
8.8	Air Filter		Clean	Replace	15 mins.
8.9	Water Quality		Verify		
8.10	Refractory replacement	Replace if needed (BMK5000 & 6000 only)			
8.13	Periodic Testing	Routine verification of functionality, various schedule			

* Only performed after initial 6-month period after initial startup.

To perform maintenance tasks in Table 8-1, the following kits are available from AERCO. All kits include a Technical Instruction Document (TID) with instructions for performing the maintenance.

Model	Kit#	Parts Serviced/Replaced	Doc Name
750 – 5000N	58025-01	Ignitor, Flame Rod, Condensate trap O rings	TID-0131
5000/6000	58025-11	Pilot Burner, Flame Rod & Condensate trap	TID-0095

Model	Kit#	Parts Serviced/Replaced – Includes all 12 Month Parts	Doc Name
750/1000	58025-08	Burner & Blower gaskets, LWCO, air filter replacement	TID-0100
	58025-17	Burner & Blower gaskets, LWCO, air filter <i>cleaner</i>	
1500/2000	58025-13	Burner & Blower gaskets, LWCO, air filter replacement	TID-0113
	58025-19	Burner & Blower gaskets, LWCO, air filter <i>cleaner</i>	
2500/3000	58025-10	Burner & Blower gaskets, LWCO, air filter replacement	TID-0102
	58025-18	Burner gaskets, LWCO, air filter <i>cleaner</i>	
4000/5000N	58025-20	Burner & Blower gaskets, LWCO, air filter replacement	TID-0215
	58025-21	Burner gaskets, LWCO, air filter <i>cleaner</i>	
5000/6000	58025-12	LWCO, air pump filter, Burner & Blower gaskets, air filter	TID-0096
	58025-14	LWCO, air pump filter, air filter	
	58025-15	LWCO, air pump filter, Burner & Blower gaskets, air filter <i>cleaning kit</i>	
	58025-16	LWCO, air pump filter, air filter <i>cleaning kit</i>	

8.2 Benchmark 750-5000N IGNITER-INJECTOR

The igniter-injector should be inspected annually and replaced at least every 24 months of operation, sooner if there is evidence of substantial erosion or carbon build-up. Parts and instructions are included in 12 Month Maintenance Kit P/N **58025-01** and all BMK750 – 5000N 24 Month Maintenance Kits.

The igniter-injector may be hot; therefore, care should be exercised to avoid burns. It is easier to remove the igniter-injector from the unit after the unit has cooled to room temperature. To inspect/replace the Igniter:

Note that during installation, use the number of indexing (clocking) washers necessary so that, when tight, the gas injection tube is positioned as shown in Figure 8-1d.

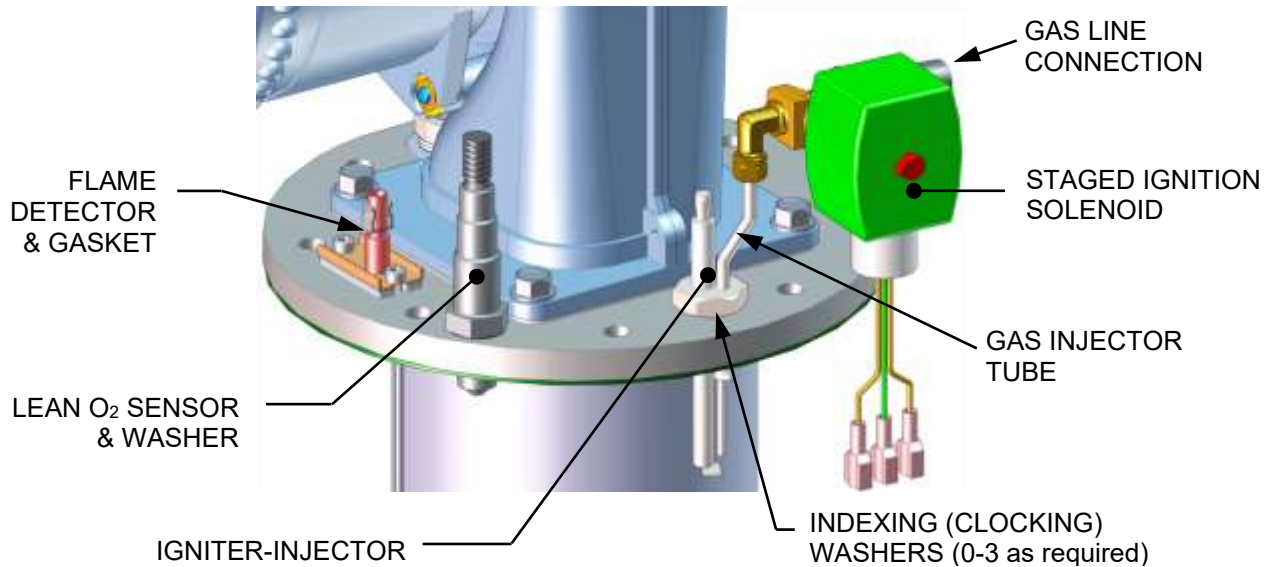

Figure 8-1a: Igniter-Injector & Flame Detector (BMK750/1000)

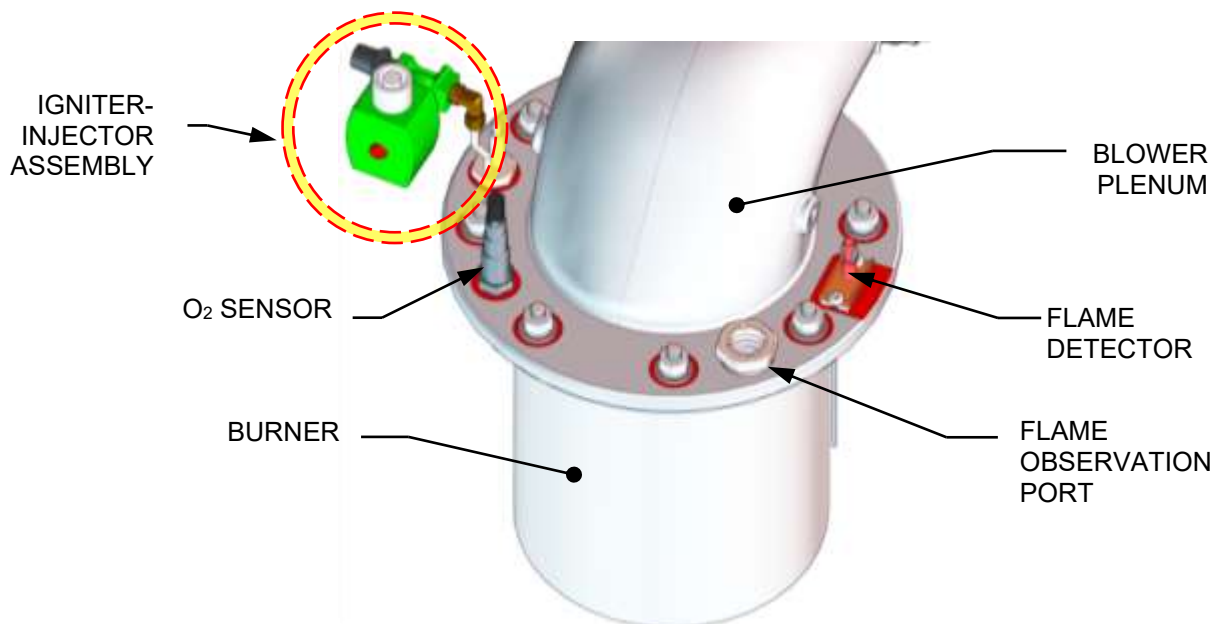

Figure 8-1b: Igniter-Injector & Flame Detector (BMK1500/2000)

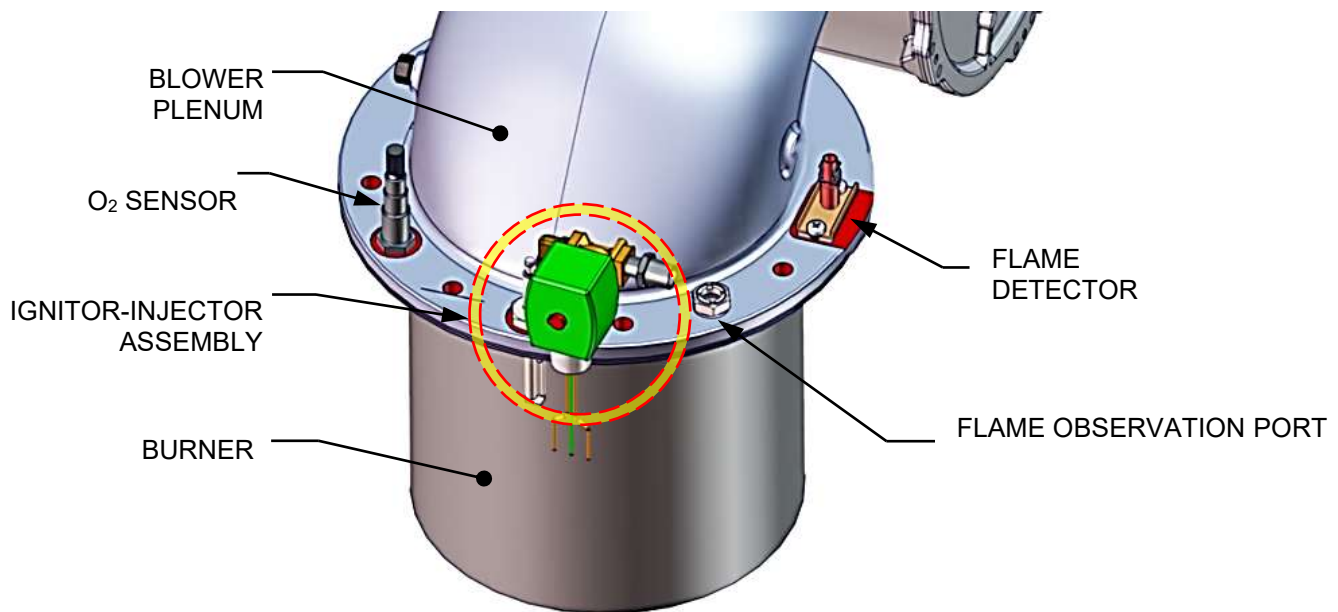

Figure 8-1c: Igniter-Injector & Flame Detector (BMK2500 – 5000N)

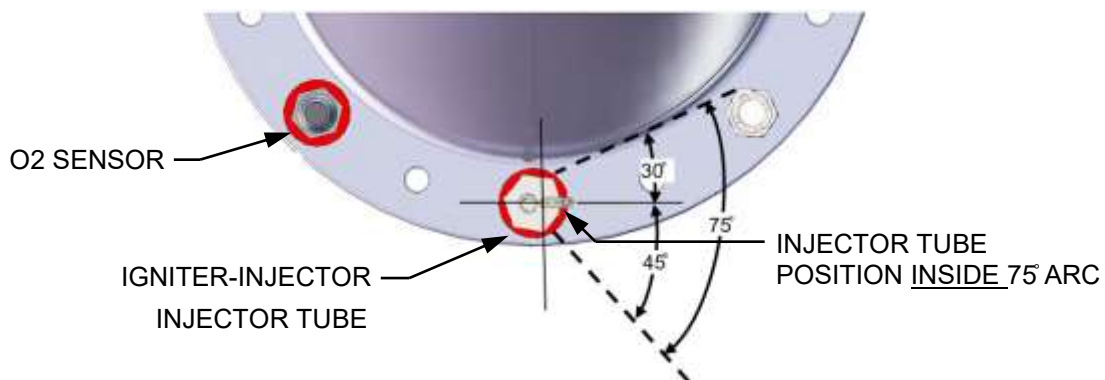

Figure 8-1d: Igniter-Injector Orientation (BMK2500 Shown)

8.2.1 Pilot Ignition – Benchmark 5000-6000

The Benchmark 5000 and 6000 Pilot Burner (P/N **66026**) is mounted to the Burner’s front plate. It should be ***inspected*** every 12 months and ***replaced*** every 24 months, or if damaged or warped.

Parts and instructions are included in 12 Month Maintenance Kit P/N **58025-11** and all BMK5000 – 6000 24 Month Maintenance Kits.

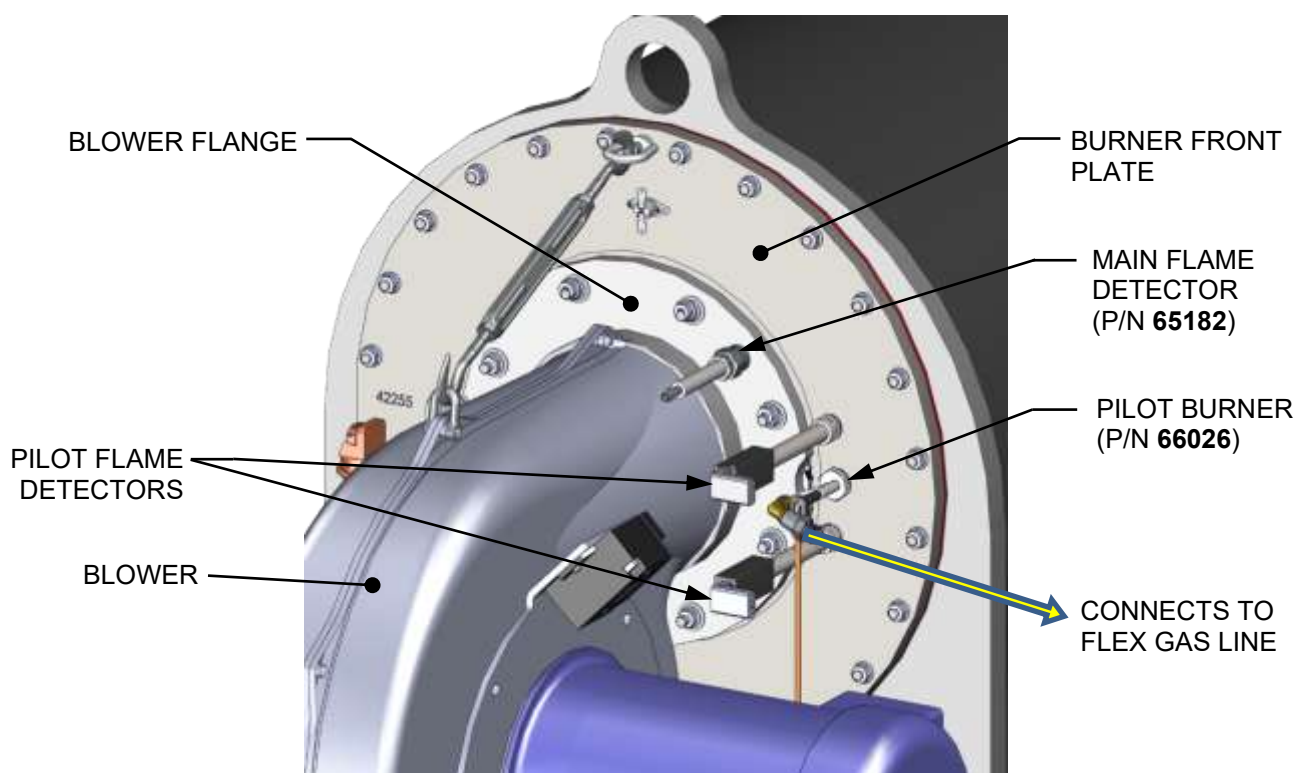

Figure 8-2: Pilot Burner and Pilot Flame Detectors (BMK5000/6000)

8.3 Flame Detector

The BMK750 – 5000N Flame Detector (kit P/N **24356-1**) is located on the burner plate at the top of the unit (see Figure 8-1a through 8-1c, above).

The BMK5000 & 6000 Main Flame Detector (P/N **65182**) is located on the Blower Flange near the top of the unit. There are also two (2) optical Pilot Flame Detectors mounted on the Burner front plate (see Figure 8-2, above).

The flame detector (and Main Flame Detector on BMK 5000/6000) should be ***inspected*** every 12 months and ***replaced*** every 24 months, or sooner if damaged or warped. Note, it may be hot; allow the unit to cool sufficiently before removing the flame detector.

Be sure to use the current model flame detector, included in the maintenance kit; some older flame detectors are shaped differently and may not function properly.

This part and instructions are included in both 12 Month Maintenance Kit P/N **58025-01** (BMK750 – 5000N) and P/N **58025-11** (BMK5000 & 6000) and all BMK750 – 6000 24 Month Maintenance Kits.

8.4 O₂ Sensor (IF EQUIPPED)

The Lean Oxygen Sensor (P/N **61026**) should be ***cleaned*** and ***inspected*** every 12 months. It is not included in any of the 12- or 24-month maintenance kits.

On BMK750 – 5000N units, it is located on the burner plate at the top of the unit. It may be hot, so allow the unit to cool sufficiently before removing or replacing it.

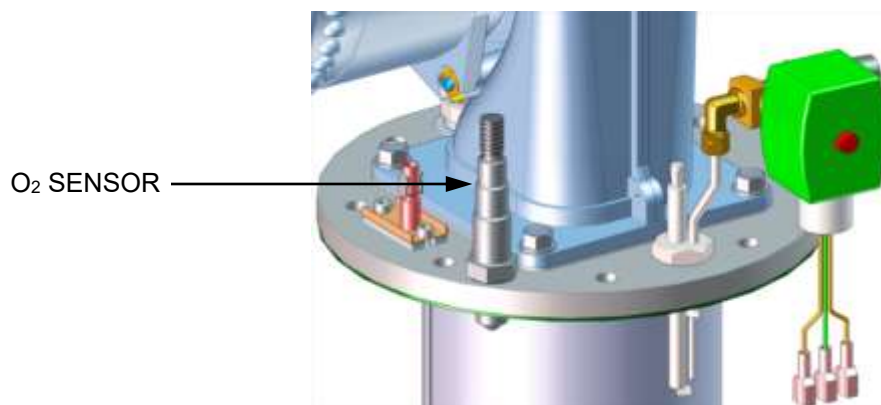

Figure 8-3a: O₂ Sensor Mounting Location – BMK750 - 5000N (BMK750 shown)

On the BMK5000 & 6000, it is located on the burner's rear plate, on the rear of the unit.

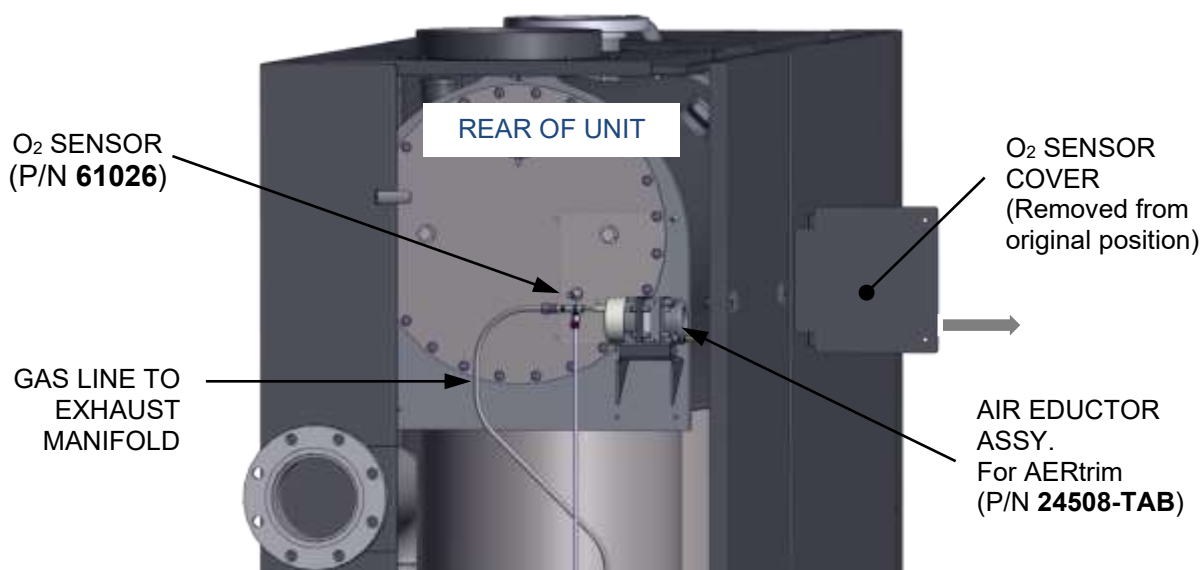

Figure 8-3b: O₂ Sensor Mounting Location – BMK5000 & 6000

Lean O₂ Sensor Maintenance Instructions

1. Set the ON/OFF switch on the Edge Controller to the **OFF** position.
2. Remove the top shroud from the unit by grasping the top handle and lifting straight up. This will disengage the shroud from the four (4) pins in the side panels.
3. Disconnect the O₂ sensor lead wire by pushing in on the release tab and pulling apart the connector.
4. Loosen and remove the O₂ sensor and crush washer from the burner plate using a 15/16" wrench.
5. Thoroughly inspect the O₂ sensor. If eroded, the sensor should be replaced. Otherwise clean the sensor with a fine emery cloth.
6. Reinstall the O₂ sensor and crush washer on the burner plate.
7. Reconnect the sensor lead wire.
8. Reinstall the shroud on the unit.

NOTE: If the AERtrim technology system is functioning, it should be inspected at the same time as O₂ sensor maintenance. For instructions see Section 9: *AERtrim Operation* in this guide.

8.4.1 Air Eductor Air Pump Maintenance (if equipped) – BMK5000 & 6000

Some Benchmark 5000 and 6000 units contain an Air Eductor assembly, mounted just inside the O₂ Sensor Cover on the unit's back panel, (see Figure 8-3b, above). It includes an air pump, which draws an air sample from the combustion chamber past the O₂ Sensor to ensure accuracy.

The air pump filter (P/N **87008**) should be **inspected** and **cleaned** every 12 months, and **replaced** every 24 months. It is included in all BMK5000 & 6000 24 Month Maintenance Kits.

Air Pump Maintenance and Troubleshooting Instructions

1. Remove the Air Pump's plastic air filter cover and clean or replace the air filter (see Figure 8-4, below).
2. If the Air Eductor or the Air Pump is not operating properly, try the following troubleshooting steps:
 - a) Check the connector to the Air Pump for corrosion or contamination; clean as needed.
 - b) If the Air Pump is not running, check 120 VAC power. If power is OK, replace pump.
 - c) If the Air Pump is running, check current drawn in series with one power wire. If the current is within the range of 0.1 to 0.6 amps, the Air Pump is operating properly.
 - d) Check the signal from current sensor. If it is within the range of 0.20 to 1.20 VDC, there may be a connector problem or IGST board issue. Check all connectors and wires first. Try swapping IGST board with known good board before ordering a new one.
3. Reattach the O₂ Sensor Cover to the unit's back panel.

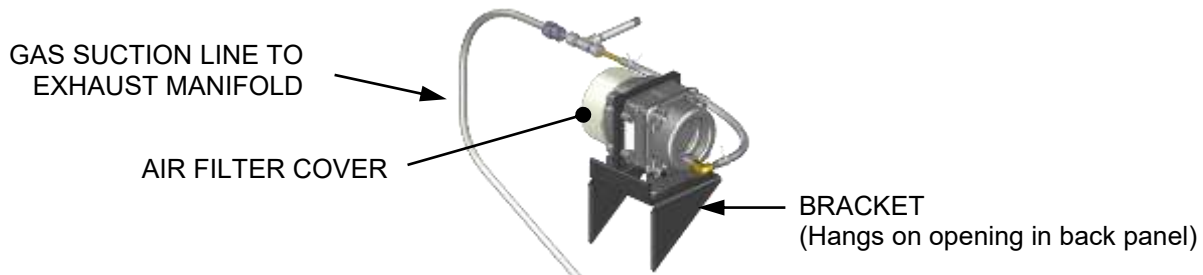

Figure 8-4: Air Eductor Assembly – BMK5000 & 6000

8.5 Safety Device Testing

Systematic and thorough tests of the operating and safety devices should be performed to ensure that they are operating as designed (see Section 5). Certain code requirements, such as ASME CSD-1, require that these tests be performed on a scheduled basis. Test schedules must conform to local jurisdictions. The results of the tests should be recorded in a logbook.

8.6 Burner Inspection

The burner assembly should be **inspected** every 24 months to ensure that all components are intact and functioning as designed. This requires the replacement of one or two burner gaskets (depending on the BMK model), and blower and gas train O-Rings, which are included in all 24 Month Maintenance Kits. If the burner is not fully intact, it must be **replaced** as soon as possible.

The burner assembly is located at the top of the unit's heat exchanger. The burner assembly may be hot. Therefore, allow the unit to cool sufficiently before removing the burner assembly.

Burner inspection parts are included all 24 Month Maintenance Kits. Instructions are in the Technical Instruction Documents (TIDs) included with the kits.

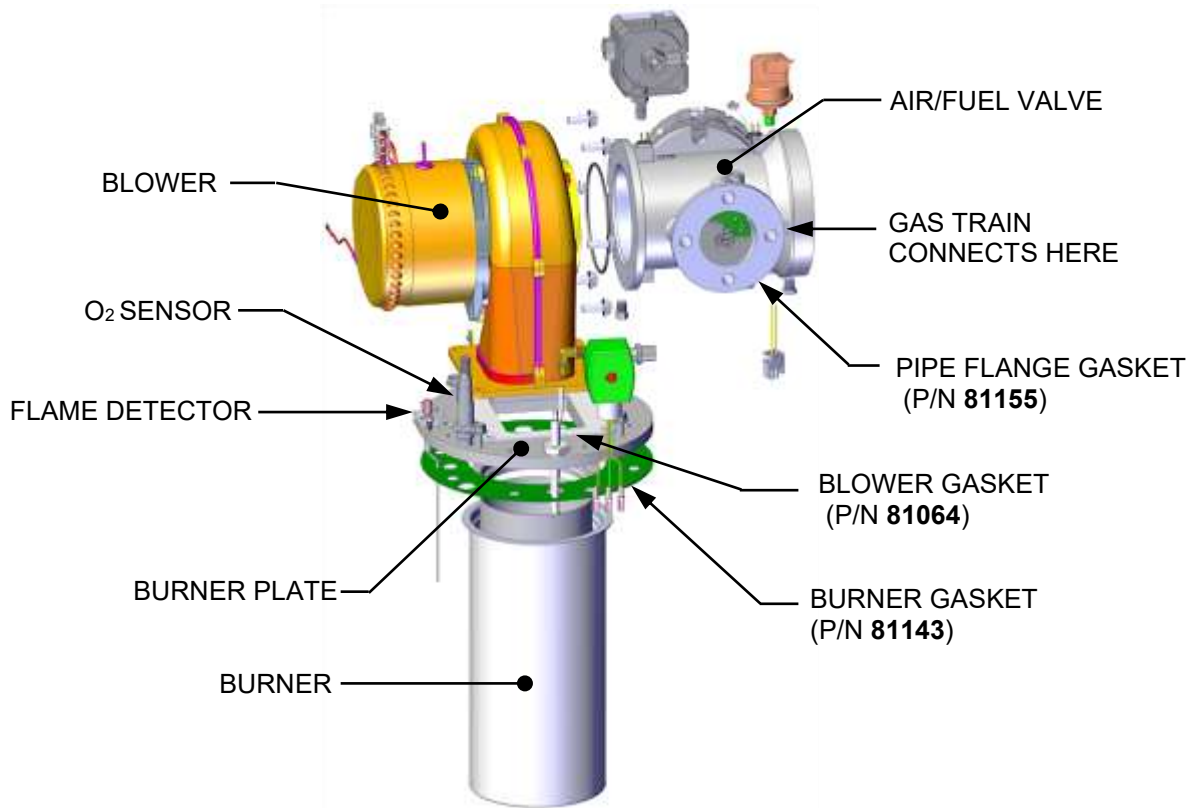

Figure 8-5a: Burner Assembly Exploded View – BMK750/1000

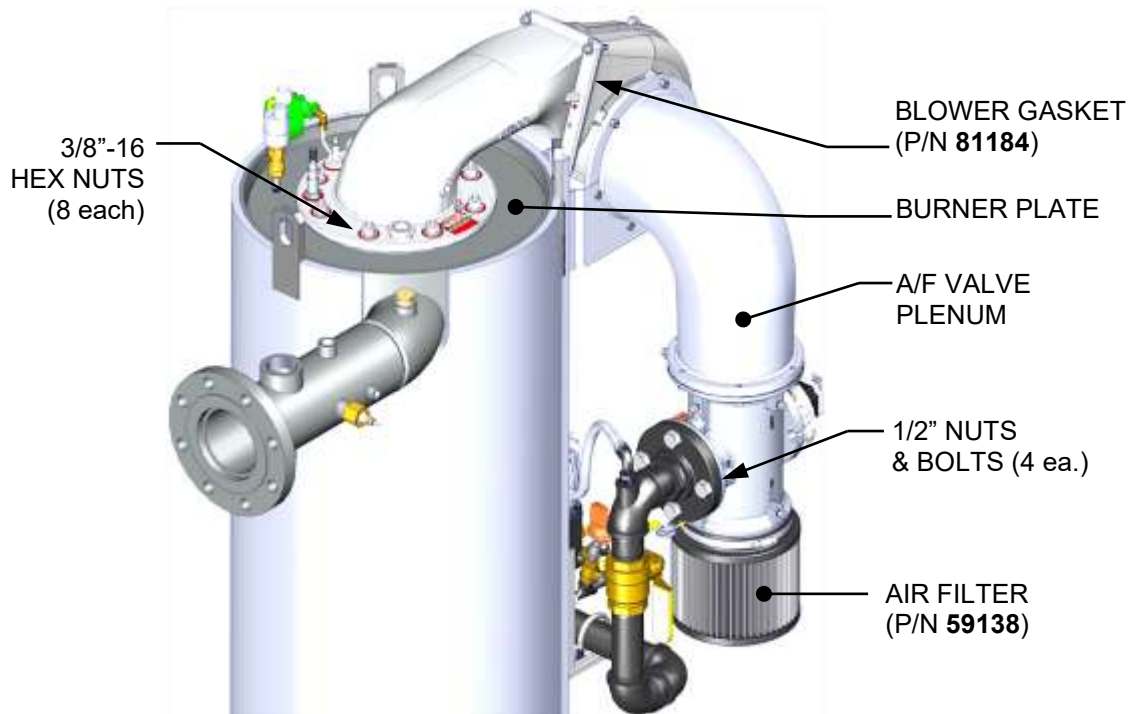

Figure 8-5b: BMK1500/2000 Burner Assembly Mounting Details

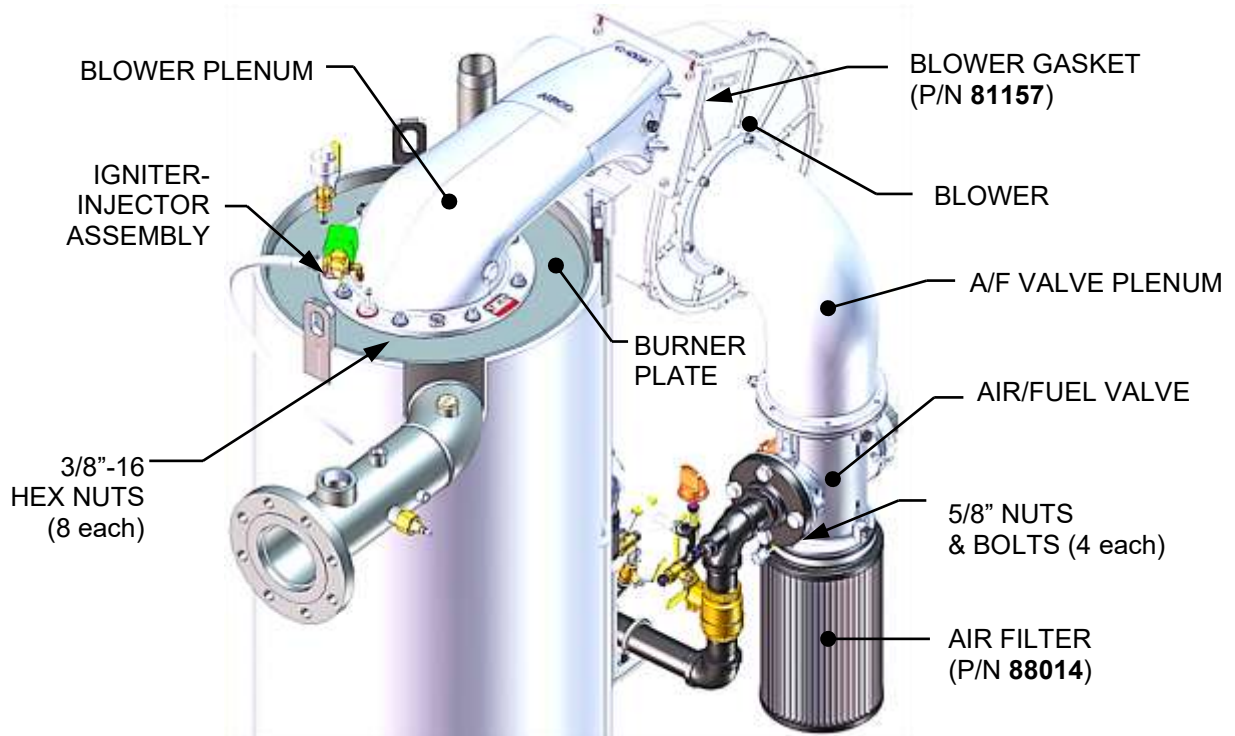

Figure 8-5c: Burner Assembly Mounting Details – BMK2500 - 5000N

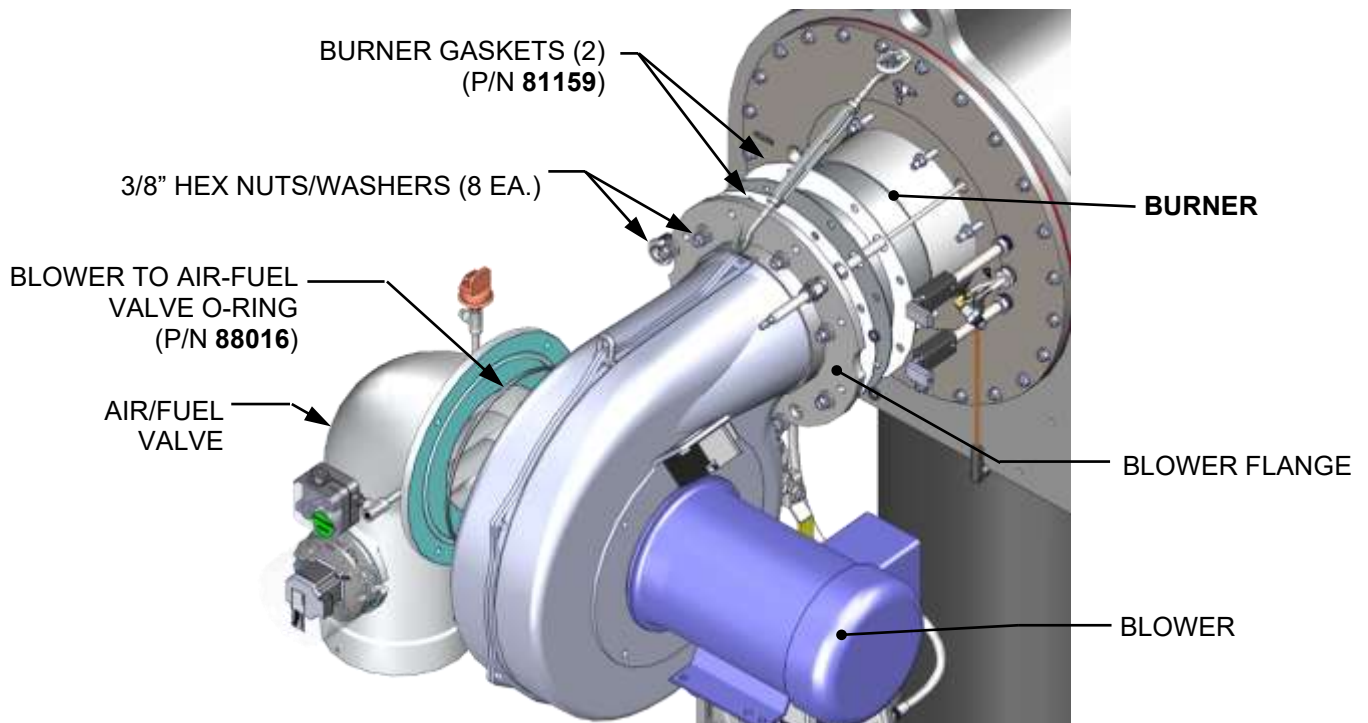

Figure 8-5d: Burner Assembly Exploded View – BMK5000 & 6000

8.7 Condensate Drain Trap

All Benchmark boilers contain an external condensate trap (P/N 24762) attached to the exhaust manifold's drain at the rear of the unit. This trap must be **inspected** and **cleaned** to ensure the float is free to move and condensate flows normally. The O-Ring (P/N 84017 included in all 24-Month Maintenance Kits) should be **replaced** if it is worn or damaged. In addition, ensure the vent (under the removable cover) is free and clear of obstructions.

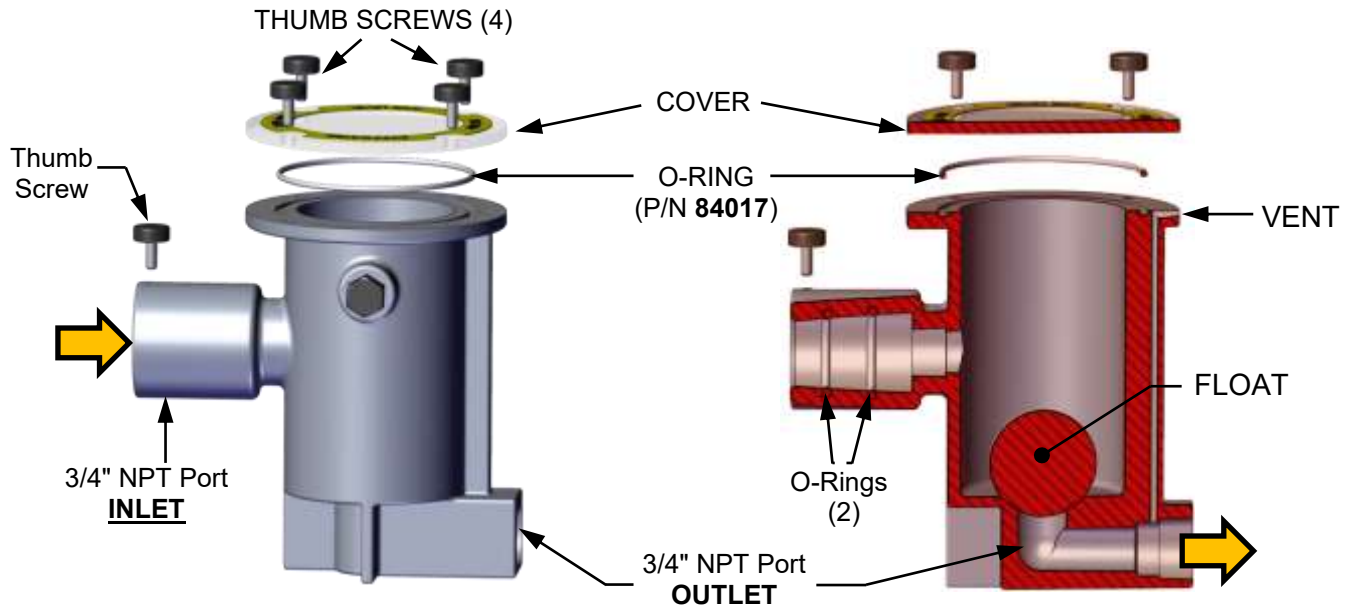

Figure 8-6: External Condensate Trap – P/N 24762

If your system includes a condensate neutralizer, the active ingredient must be replaced periodically.



Figure 8-7: Condensate Trap and Neutralizer

8.8 Air Filter Cleaning and Replacement

The boiler's air filter should be **cleaned** every 12 months and **replaced** after 24 months if it shows any deterioration. However, if it is still in good condition, you can order a 24 Month Maintenance kit that includes an air filter cleaning kit in place of a new filter. **NOTE:** *Failure to clean or replace the air filter may affect stable combustion and may result in less efficient operation and combustion reliability issues.*

All 24 Month Maintenance Kits include one of two parts:

- **An Air Filter Cleaning Kit** – Appropriate if the filter is intact.
- **New Air Filter** – Necessary if the filter is deteriorated or damaged.

Check Table 8-2b, above, to find the part number of the kit appropriate for your site. Instructions are included in the TID that accompanies the kit.

8.9 Water Quality

To prevent corrosion and fouling, the water quality guidelines below should be adhered to:

- Chloride limits are set to 250 ppm to prevent corrosion of the heat exchanger. In the table below, your Chloride test result dictates which row you must be in.
- Sulfates are limited to lower ppm limits as the tested chloride levels increase and are acceptable at any ppm when chlorides are less than 100 ppm.
- Allowable hardness depends on concentration of sulfates and chlorides; should not exceed 50 ppm.
- **EXAMPLE:** If the chloride is between 175 and 250, sulfate must be 25 ppm or below and hardness must be 10 ppm or below for the boiler to operate smoothly with minimal risk.
- **MAINTENANCE:** Water quality should be analyzed 3 months after startup. If in compliance with guidelines below, water quality should be analyzed as part of annual maintenance.

NOTE: Leaks can cause significant amounts of make-up water, creating a loop that is no longer “closed” and allowing contaminants in. AERCO recommends installation a positive displacement flow meter on the make-up water line to sense any freshwater make-up introduction. In the event of freshwater being introduced into the boiler loop, water quality should be verified and treated as necessary to meet guidelines below. Contact your local AERCO Sales Representative or AERCO Technical Services if you have any questions.

Chloride (ppm)	Sulfate (ppm)	Hardness (ppm)	pH	Conductivity
< 250	≤ 25	≤ 10	7-10.5	≤ 3500 umho/cm
< 175	≤ 50	≤ 25	7-10.5	≤ 3500 umho/cm
< 100	No Limit	≤ 50	7-10.5	≤ 3500 umho/cm

- **Chlorides** - Causes stainless steel to corrode
- **Sulfates** – Accelerates corrosion of stainless steel in the presence of chlorides
- **Hardness** - Keeping hardness values low will help to prevent scale buildup
- **pH** – The first step towards boiler treatment, maintain between 7-10.5
- **Conductivity** - The increase of total solids promotes deposition of scales

8.10 Refractory Replacement – BMK5000 & 6000 ONLY

A low mass, fiber-based material insulates the front and rear end plates of the combustion chamber. This material has very low thermal conductivity and is not susceptible to thermal shock conditions that cause failures of hard-faced refractory materials.

⚠ WARNING!

- **The heat exchanger insulation utilizes ceramic fiber material. Wear a fitted NIOSH-approved particulate respirator (3m n95 or equivalent) When servicing the heat exchanger and burner assemblies. At high temperatures, ceramic fibers can be converted to crystalline silica fibers, which have been identified as carcinogenic when inhaled.**

If access to the unit’s combustion chamber is required, the preferred method is to remove the rear refractory first, since it is a much less complicated procedure; removing the front refractory requires first removing the blower, burner and air/fuel valve assemblies before reaching the refractory material.

If either the front or rear refractory needs to be replaced, obtain one of the Benchmark 5000/6000 Refractory Replacement kits from AERCO. There are three kits available:

- P/N **58197-1** – Front Refractory for units with Front Burner Plate 42255
- P/N **58197-2** – Front Refractory for units with Front Burner Plate 43071
- P/N **58197-3** – Rear Refractory

8.11 Shutting Boiler Down For Extended Period

If the boiler is to be taken out of service for an extended period of time (one year or more), the following instructions must be followed.

1. Set Enable/Disable switch on front panel to **Disable** to shut down the boiler’s operating controls.
2. Disconnect AC power from the unit.
3. Close the water supply and return valves to isolate boiler.
4. Close external gas supply valve.
5. Open relief valve to vent water pressure.
6. Open the drain valve and drain all water from the unit.
7. If the temperature may get below freezing **for even a short time** you must drain **all** water from the unit. Step 6 is not sufficient, as it leaves some water in the bottom of the heat exchanger chamber. You must use a suction pump inserted through the inspection ports to remove **all** water from the bottoms of the heat exchanger chamber and base assembly.

⚠ WARNING!
 If temperature falls below freezing, failure to drain all water can cause heat exchanger tubes to fail.

8.11.1 Benchmark 5000 & 6000 Long Term Blower Storage

Benchmark 5000 and 6000 blowers can be damaged if left in long term storage (30+ days after receipt). If kept in storage for more than 30 days, complete the instructions below.

1. Select a suitable storage site:
 - Level, well-drained, firm surface, in clean, dry and warm location (minimum of 50°F (10°C).
 - Isolated from possibility of physical damage from construction vehicles, erection equipment, etc.
 - Accessible for periodical inspection and maintenance.
2. The blower should be supported under each corner of its base to allow it to “breathe”. Supports (2 x 4’s, timbers, or railroad ties) should be placed diagonally under each corner.
3. If the equipment is to be stored for more than three (3) months, the entire blower assembly must be loosely covered with plastic, but not tightly wrapped.
4. Storage Maintenance: A periodic inspection and maintenance log, by date and action taken, must be developed and maintained for each blower. See example below. Each item must be checked monthly.

Example Storage / Maintenance Schedule Log		
Item	Action	Dates Checked
1	Re-inspect units to ensure any protective devices used are functioning properly. Check for scratches in finish which will allow corrosion to form	
2	CRITICAL: Rotate wheel a minimum of 10 full revolutions to keep the motor bearing grease from separating and drying out.	

5. General Motor Procedure: If the motor is not put into service immediately, it must be stored in a clean, dry location with a minimum temperature of 50°F. (10°C,). In addition:

- a) Use a “Megger” each month to ensure integrity of the winding insulation is maintained. Record the Megger readings. Immediately investigate any significant drop in insulation resistance.
- b) DO NOT lubricate motor bearings during storage; they are packed with grease at the factory.
- c) If the storage location is damp or humid, the motor windings must be protected from moisture by applying power to the motor’s space heaters (if available). Otherwise, storing it in a damp or humid location will quickly cause internal corrosion and motor failure.

NOTE: For specific storage instructions, for the actual motor and any accessory parts that were supplied, refer to the manufacturer’s instructions.

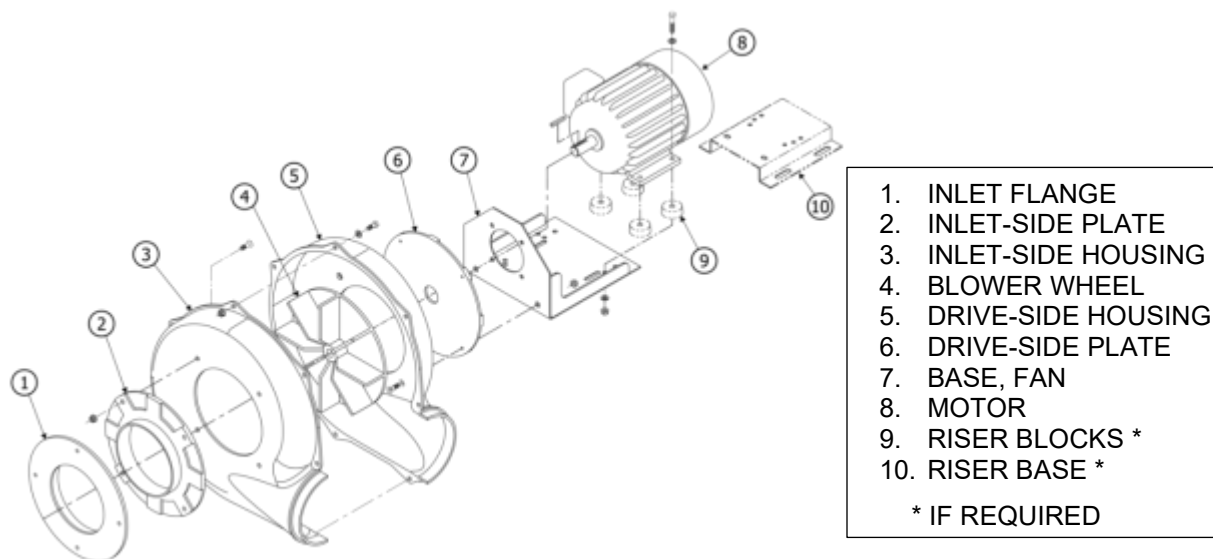

Figure 8-8: Benchmark 6000 Blower Exploded View

8.12 Returning The Boiler To Service After Shutdown

After a prolonged shutdown (one year or more), the following procedures must be followed:

- 1. Review installation requirements in the *Benchmark -Edge: INSTALLATION Manual* (OMM-0136).
- 2. Inspect all piping and connections to the unit.
- 3. Inspect exhaust vent and air inlet duct work (if applicable).
- 4. Perform initial startup per Section 4 of this guide.
- 5. Perform the instructions in Section 5 and all scheduled procedures described in Section 8.

8.13 Recommended Periodic Testing

⚠ WARNING!

The owner or user of an automatic boiler system should set up a formal system of periodic preventive maintenance and testing. Tests should be conducted on a regular basis and the results recorded in a logbook.

TABLE 8-3: Recommended Periodic Testing			
ITEM	FREQUENCY	ACTION BY	REMARKS
Gauges, monitors and indicators	Daily	Operator	Visual inspection and record readings in operator log
Instrument and equipment settings	Daily	Operator	Visual check against factory recommended specifications
	Weekly	Operator	Verify factory settings
Firing Rate Control	Semi-Annually	Service Tech	Verify factory settings
	Annually	Service Tech	Check with combustion calibration test equipment (see Section 4.2: <i>Tools & Instruments for Combustion Calibration</i> in this guide), and the O ₂ sensor (see Section 8.4: <i>O₂ Sensor</i> in this guide).
Flue, vent, stack and intake air duct	Monthly	Operator	Visually inspection condition and check for obstructions
Spark Igniter-Injector	Weekly	Operator	See Section 8.2: <i>Ignitor-Injector</i> of this guide.
Air/Fuel Valve position	Weekly	Operator	Check position indicator dial. See Section 3.2: <i>Start Sequence</i> in this guide.
SSOV Leakage test	Annually	Service Tech	Check for leakage in accordance with the SSOV manufacturer's (Siemens) recommendations.
Flame failure	Weekly	Operator	Close manual gas shutoff valve and check safety shutdown. See Section 5.7: <i>Flame Fault Test</i> of this guide.
Flame signal strength	Weekly	Operator	Check flame strength in the Edge Controller's <i>Unit Status</i> screen.
Low water level cut off and alarm	Weekly	Operator	See Section 5.4: <i>Low Water Level Fault Test</i> in this Guide.
Slow drain test	Semi-Annually	Operator	Perform a slow drain test in accordance with ASME Boiler and Pressure Vessel Code, Section IV.
High water temp. safety control test	Annually	Service Tech	See Section 5.5: <i>Water Temperature Fault Test</i> in this guide.
Operating controls	Annually	Operator	See Section 2: <i>Edge Controller Operation</i> in this guide.
Low air flow	Monthly	Operator	See Section 5.8: <i>Air Flow Fault Tests</i> and Section 8.8: <i>Air Filter Cleaning and Replacement</i> in this guide.
High and low gas pressure interlocks	Monthly	Operator	See Sections 5.2: <i>Low Gas Pressure Test</i> and 5.3: <i>High Gas Pressure Test</i> in this guide.
Air/Fuel Valve purge position switch	Annually	Service Tech	See Section 5.10 <i>Purge Switch Open During Purge</i> in this guide.
Air/Fuel Valve ignition position switch	Annually	Service Tech	See Section 5.11: <i>Ignition Switch Open During Ignition</i> in this guide.
Safety valves	As required	Operator	Check per A.S.M.E. Boiler and Pressure Vessel Code, Section IV.
Inspect burner components	Semi-Annually	Service Tech	See Section 8.6: <i>Burner Inspection</i> in this guide.
Condensate Trap	Semi-Annually	Operator	See Section 8.7: <i>Condensate Drain Trap</i> in this guide.
Oxygen (O ₂) Level	Monthly	Operator	Verify O ₂ level is between 3% and 8% during operation.

8.14 Recommended Spares

NOTE: Refer to the parts list illustrations in the *Benchmark -Edge: REFERENCE Manual* (OMM-0138) for the locations of the parts listed below.

For a list of 12- and 24-Month Maintenance Kits, see Section 8.1: *Maintenance Schedule*.

TABLE 8-4: Recommended Emergency Spare Parts				
DESCRIPTION	BMK 750/1000	BMK 1500/2000	BMK 2500-5000N	BMK 4000-5000N
VAC Blower Replacement Kit	58061	58038	58063-1 – 460V 58063-2 – 208V	58195-1 (480V) 58195-2 (208V)
SSOV Actuator/Regulator Combo - Used on: <ul style="list-style-type: none"> • ALL FM gas trains • Downstream SSOV on DBB gas trains 	64048	64048	64048	64048
SSOV Actuator <u>without</u> Proof of Closure Switch - <ul style="list-style-type: none"> • Used on Upstream SSOV on DBB gas trains 	27086-1	27086-1	27086-1	
Actuator Replacement Kit: SSOV with P.O.C. Switch Kit				27086-6

TABLE 8-5: Recommended Emergency Spare Parts – BMK5000 & 6000	
DESCRIPTION	PART NUMBER
Actuator Replacement Kit: SSOV with P.O.C. Switch Kit	27086-2
Actuator Replacement Kit: SSOV with Regulator, POC Switch & Damping Orifice	64106
Pilot Regulator w/ 2-6" Spring	24384
Pilot Solenoid Valve, 1/4" NPT FRU Kit	58089
Temperature Switch - Manual Reset	123552
Ignitor Rod FRU Kit (component of Flame Rod Assy. 65150)	65182

TABLE 8-6: Optional Spare Parts		
DESCRIPTION	PART NUMBER	
Edge Controller	64142	
Burner	BMK750 & 1000	46026
	BMK1500	46042
	BMK2000	46044
	BMK2500	46039
	BMK3000	46038
	BMK4000 & 5000N	46060
	BMK5000 & 6000	46025
Oxygen Sensor	61026	

SECTION 9: AERTRIM OPERATION (IF EQUIPPED)

9.1 AERtrim Introduction

Advanced combustion control systems need to maintain precise air/fuel ratios to maximize efficiency. Gas and oil-fired boilers often deviate from the ideal air-fuel ratio due to environmental variations such as humidity, atmospheric pressure, filter dust loading, delivered gas energy content and other factors. If the boiler is operating with fixed blower/damper positions, the air/fuel ratio will normally vary within an acceptable level but will not be fully optimized for efficiency and reliability.

The AERtrim system is designed to measure and maintain an ideal air-fuel ratio in Benchmark boilers, thus maximizing efficiency and reliability while minimizing emissions. It does this by first measuring post combustion oxygen percentages inside the combustion chamber. This data is fed through the Electronic Control Unit (ECU) which is connected to the Edge Controller inside the boiler. If the oxygen readings are outside of preset or user defined values, the blower voltage is changed in small increments until the reading falls within the ideal range.

A simplified representation of the system is shown in Figure 9-1.

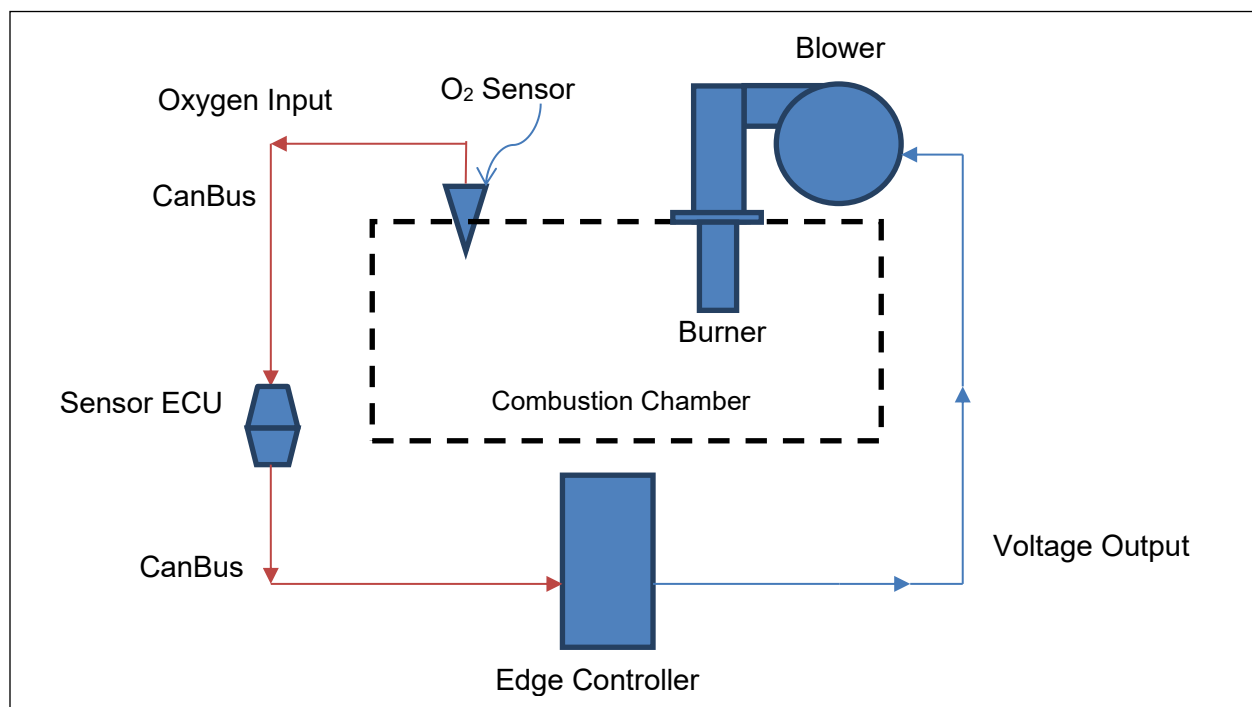

Figure 9-1: Simplified AERtrim Diagram

⚠ WARNING!

AERtrim and combustion calibration can both alter the voltage sent to the blower and can thus interfere with each other. If a change is made to any calibration point during combustion calibration, you must make a corresponding change to the same calibration point in AERtrim. If you fail to make the change in AERtrim, AERtrim may ignore the combustion calibration value and adjust the O₂ to the AERtrim value instead.

See OMM-0139 for complete AERtrim instructions and menu options.

9.2 AERtrim Activation

AERtrim is activated at the factory prior to shipping. However, if the Edge Controller is replaced for any reason, you must activate AERtrim by entering an activation code, as described below. Note that the activation code for each unit is unique, based on the unit's serial number, and thus cannot be transferred to any other unit; **if you have multiple units, you must install the correct code on the correct unit.**

1. Record the following information from the unit. Go to **Main Menu → Advanced Setup → Performance → AERtrim → AERtrim Settings** and scroll down to the following parameters:
 - **Unit Serial #**, found on the unit's code plate. For example, G-18-1050
 - **Trim ID**
 - **Fixed ID**

NOTE: When recording the information above, do not power cycle the boiler, as that can change the Trim ID.

2. Contact your local AERCO Sales Representative with the information found in step 1. They will provide you with an activation code.
3. Once you have obtained the activation code, go back to **Main Menu → Advanced Setup → Performance → AERtrim → AERtrim Settings**.
4. Find the **Activation Code** parameter, enter the activation code and press **Save**.
5. Scroll back to the top of the **AERtrim Settings** screen and set the **AERtrim** parameter to **Enabled**.
6. Go to the **AERtrim → O2 Trim Parameters** screen. The **O2 Target**, **O2 Upper Limit** and **O2 Lower Limit** parameters are at default values but can be changed as needed.

NOTE: For full instructions, including all menu options, see the *Edge Controller Manual*, Section 6.6.1.

9.3 Operation Details

During operation, the AERtrim system adjusts the command voltage sent to the combustion air blower. The amount of voltage trim depends on the error between the desired O₂% and the O₂ sensor reading (O₂%) and also on high and low limits of blower voltage for each valve position. The total corrective voltage trim is limited by the controller to ensure safe and reliable operation of the system.

Figure 9-2 shows the functional logic of the AERtrim system and how the blower voltage (BV) O₂ Limits, and air/fuel ratio interact during an AERtrim operation. These are fixed presets within the controller. The target range is adjustable within these limits to allow the user to select the optimal air/fuel ratio for a particular boiler or application.

Figure 9-2 shows how the controller would react to an O₂% reading above the upper limit. The controller will reduce the blower voltage (BV) until the O₂% reading is within the Target Range, provided the BV adjustments are within the BV limits for that unit at that fire rate. The control will then store this as the new BV calibration setting until changed manually or by another cycle of the AERtrim function.

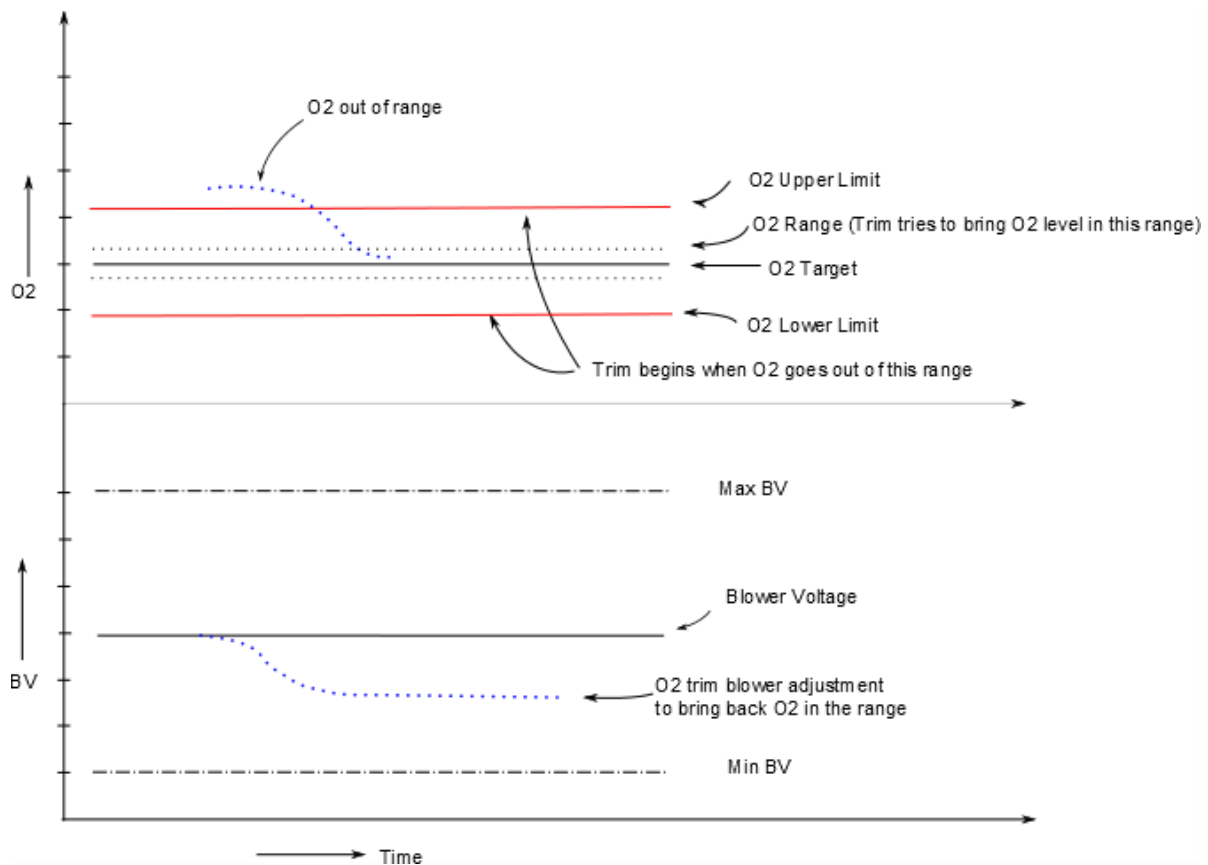

Figure 9-2: AERtrim Logic

Once the operational stability conditions are met, the AERtrim system will execute the following steps:

1. Lock the fire rate at the current position that needs adjustment to the air/fuel ratio.
2. The **Demand** LED will flash once per second to indicate that the trim function has started.
3. Check the oxygen levels inside the combustion chamber:
 - If oxygen levels are within the set range, AERtrim releases control.
 - If oxygen levels are outside the set range, AERtrim will adjust Blower Voltage to bring the boiler back to the Target O₂ value.

This process repeats until the target oxygen range is achieved or the unit reaches the allowable blower voltage limit.

9.4 O₂ Sensor Calibration

O₂ sensor calibration can be initiated by pressing the Calibrate button on the Edge's **O₂ Sensor screen (Main Menu → Calibration → Input/Output → O₂ Sensor)**. Connect the combustion analyzer to the exhaust to perform the O₂ sensor calibration. Once the calibration starts, the Edge ignites the unit and waits two minutes for the sensor to settle. Enter the O₂ reading from the analyzer to complete the calibration process.

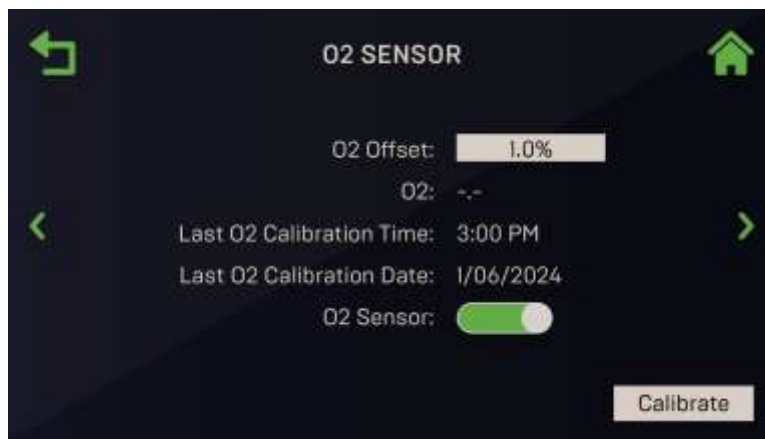

Figure 9-3: O2 Sensor Calibration Screen

9.5 AERtrim Menu Values and Defaults

There are three AERtrim screens. Go to [Main Menu](#) → [Advanced Setup](#) → [Performance](#) → [AERtrim](#).

- **AERtrim Settings:** To enable AERtrim, set the **AERtrim** parameter to **Enabled**. You can then adjust the **O2 Offset**, **Settle Time**, **Trim Gain** and **Trim Iteration Limit** parameters to values appropriate for the unit, per the tables below.



- **O2 Trim Parameters:** Choose a **Valve Position** and then set the **O2 Target**, **Upper** and **Lower Limits** for the valve position. Repeat for all valve positions, per the tables below.

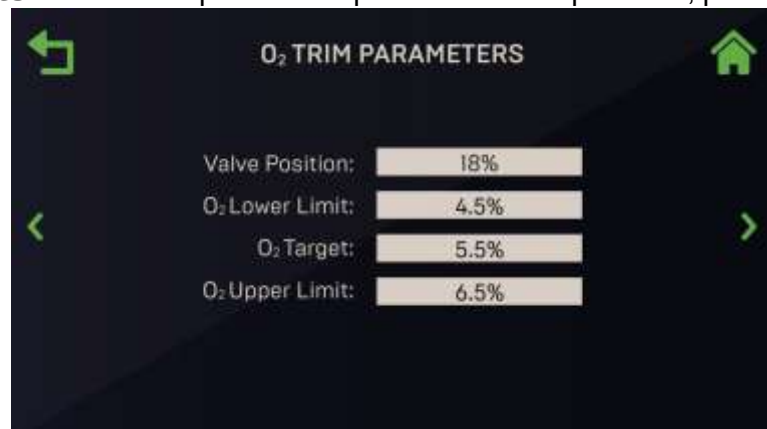

SECTION 9 – AERTRIM OPERATION

- **AERtrim Status:** Displays the current status of AERtrim operation.



For more information, see the *Edge Controller Manual* (OMM-0139) Section 6.6.1.

BMK750 AERtrim Values				
MENU ITEM		Minimum	Maximum	Default
Settle Time		0	120 Sec	20 Sec
Trim Gain		0.1	5.0	0.250
Max Tries		0	100	15
O ₂ Target (must be between O ₂ Upper & O ₂ Lower)	18%	3%	8%	5.5%
	30%	3%	8%	5.5%
	45%	3%	8%	5.5%
	60%	3%	8%	5.5%
	80%	3%	8%	5.5%
O ₂ Lower Limit (must be at least 1% lower than O ₂ Upper)	100%	3%	8%	5.0%
	18%	2.5%	5.5%	4.5%
	30%	2.5%	5.5%	4.5%
	45%	2.5%	5.5%	4.5%
	60%	2.5%	5.5%	5.0%
O ₂ Upper Limit (must be at least 1% higher than O ₂ Lower)	80%	2.5%	5.5%	5.0%
	100%	2.5%	5.5%	4.5%
	18%	5.5%	8.5%	6.5%
	30%	5.5%	8.5%	6.5%
	45%	5.5%	8.5%	6.5%
O ₂ Offset	60%	5.5%	8.5%	6.0%
	80%	5.5%	8.5%	6.0%
	100%	5.5%	8.5%	5.5%
O ₂ Offset		-3.0	3.0	1.0

BMK750 AERtrim Adjustment Range			
CALIBRATION POINT	BLOWER VOLTAGE		
	Minimum	Maximum	Default
18%	1.75	2.85	2.10
30%	1.95	2.60	2.55
45%	2.35	3.60	3.10
60%	3.00	3.90	3.50
80%	3.80	4.75	4.60
100%	4.75	6.00	5.60

SECTION 9 – AERTRIM OPERATION

BMK1000 AERtrim Values				
MENU ITEM		Minimum	Maximum	Default
Settle Time		0	120 Sec	20 Sec
Trim Gain		0.1	5.0	0.250
Max Tries		0	100	15
O ₂ Target (must be between O ₂ Upper & O ₂ Lower)	18%	3%	8%	5.5%
	30%	3%	8%	5.5%
	45%	3%	8%	5.5%
	60%	3%	8%	5.5%
	80%	3%	8%	5.5%
	100%	3%	8%	5.0%
O ₂ Lower Limit (must be at least 1% lower than O ₂ Upper)	18%	2.5%	5.5%	4.5%
	30%	2.5%	5.5%	4.5%
	45%	2.5%	5.5%	5.0%
	60%	2.5%	5.5%	5.0%
	80%	2.5%	5.5%	5.0%
	100%	2.5%	5.5%	4.5%
O ₂ Upper Limit (must be at least 1% higher than O ₂ Lower)	18%	5.5%	8.5%	6.5%
	30%	5.5%	8.5%	6.5%
	45%	5.5%	8.5%	6.0%
	60%	5.5%	8.5%	6.0%
	80%	5.5%	8.5%	6.0%
	100%	5.5%	8.5%	5.5%
O ₂ Offset		-3.0	3.0	1.0

BMK1000 AERtrim Adjustment Range			
CALIBRATION POINT	BLOWER VOLTAGE		
	Minimum	Maximum	Default
18%	1.20	2.85	2.10
30%	1.95	2.60	2.55
45%	2.35	3.60	3.10
60%	3.00	3.90	3.50
80%	3.80	4.75	4.60
100%	4.75	6.00	5.60

SECTION 9 – AERTRIM OPERATION

BMK1500 AERtrim Values				
MENU ITEM		Minimum	Maximum	Default
Settle Time		0	120 Sec	20 Sec
Trim Gain		0.1	5.0	0.250
Max Tries		0	100	15
O ₂ Target (must be between O ₂ Upper & O ₂ Lower)	16%	3%	8%	5.5%
	30%	3%	8%	6.5%
	40%	3%	8%	6.5%
	50%	3%	8%	6.5%
	70%	3%	8%	6.0%
	100%	3%	8%	5.0%
O ₂ Lower Limit (must be at least 1% lower than O ₂ Upper)	16%	2.5%	5.5%	5.0%
	30%	2.5%	5.5%	5.0%
	40%	2.5%	5.5%	5.0%
	50%	2.5%	5.5%	5.0%
	70%	2.5%	5.5%	5.0%
	100%	2.5%	5.5%	4.5%
O ₂ Upper Limit (must be at least 1% higher than O ₂ Lower)	16%	5.5%	8.5%	6.0%
	30%	5.5%	8.5%	7.0%
	40%	5.5%	8.5%	7.0%
	50%	5.5%	8.5%	7.0%
	70%	5.5%	8.5%	6.5%
	100%	5.5%	8.5%	5.5%
O ₂ Offset		-3.0	3.0	1.0

BMK1500 AERtrim Adjustment Range			
CALIBRATION POINT	BLOWER VOLTAGE		
	Minimum	Maximum	Default
16%	1.40	3.30	1.80
30%	1.90	4.60	2.30
40%	2.30	5.70	2.50
50%	2.50	5.70	2.90
70%	2.70	6.30	3.80
100%	6.00	10.00	7.90

SECTION 9 – AERTRIM OPERATION

BMK2000 AERtrim Values				
MENU ITEM		Minimum	Maximum	Default
Settle Time		0	120 Sec	20 Sec
Trim Gain		0.1	5.0	0.250
Max Tries		0	100	15
O ₂ Target (must be between O ₂ Upper & O ₂ Lower)	18%	3%	8%	6.5%
	30%	3%	8%	6.0%
	40%	3%	8%	6.0%
	50%	3%	8%	5.5%
	70%	3%	8%	5.5%
	100%	3%	8%	5.0%
O ₂ Lower (must be at least 1% lower than O ₂ Upper)	18%	2.5%	5.5%	5.0%
	30%	2.5%	5.5%	5.5%
	40%	2.5%	5.5%	5.5%
	50%	2.5%	5.5%	5.0%
	70%	2.5%	5.5%	5.0%
	100%	2.5%	5.5%	4.5%
O ₂ Upper (must be at least 1% higher than O ₂ Lower)	18%	5.5%	8.5%	7.0%
	30%	5.5%	8.5%	6.5%
	40%	5.5%	8.5%	6.5%
	50%	5.5%	8.5%	6.0%
	70%	5.5%	8.5%	6.0%
	100%	5.5%	8.5%	5.5%
O ₂ Offset		-3.0	3.0	1.0

BMK2000 AERtrim Adjustment Range			
CALIBRATION POINT	BLOWER VOLTAGE		
	Minimum	Maximum	Default
18%	1.90	4.00	1.40
30%	2.70	7.70	3.80
40%	3.00	7.70	4.30
50%	3.30	7.70	5.40
70%	4.00	9.60	6.40
100%	6.00	10.00	9.50

SECTION 9 – AERTRIM OPERATION

BMK2500 AERtrim Values				
MENU ITEM		Minimum	Maximum	Default
Settle Time		0	120 Sec	20 Sec
Trim Gain		0.1	5.0	0.250
Max Tries		0	100	15
O ₂ Target (must be between O ₂ Upper & O ₂ Lower)	16%	3%	8%	5.5%
	30%	3%	8%	6.5%
	40%	3%	8%	7.0%
	50%	3%	8%	6.0%
	70%	3%	8%	6.0%
	100%	3%	8%	5.0%
O ₂ Lower (must be at least 1% lower than O ₂ Upper)	16%	2.5%	5.5%	5.0%
	30%	2.5%	5.5%	4.5%
	40%	2.5%	5.5%	5.0%
	50%	2.5%	5.5%	5.5%
	70%	2.5%	5.5%	5.5%
	100%	2.5%	5.5%	4.5%
O ₂ Upper (must be at least 1% higher than O ₂ Lower)	16%	5.5%	8.5%	6.0%
	30%	5.5%	8.5%	7.0%
	40%	5.5%	8.5%	7.5%
	50%	5.5%	8.5%	6.5%
	70%	5.5%	8.5%	6.5%
	100%	5.5%	8.5%	5.5%
O ₂ Offset		-3.0	3.0	1.0

BMK2500 AERtrim Adjustment Range			
CALIBRATION POINT	BLOWER VOLTAGE		
	Minimum	Maximum	Default
16%	1.90	2.90	2.20
30%	3.00	4.90	4.10
40%	3.70	5.90	4.80
50%	4.20	6.40	5.30
70%	5.20	8.40	6.80
100%	6.50	9.20	8.50

SECTION 9 – AERTRIM OPERATION

BMK3000 AERtrim Values				
MENU ITEM		Minimum	Maximum	Default
Settle Time		0	120 Sec	20 Sec
Trim Gain		0.1	5.0	0.250
Max Tries		0	100	15
O ₂ Target (must be between O ₂ Upper & O ₂ Lower)	14%	3%	8%	6.5%
	30%	3%	8%	7.3%
	40%	3%	8%	7.5%
	50%	3%	8%	7.0%
	70%	3%	8%	5.5%
	100%	3%	8%	5.0%
O ₂ Lower (must be at least 1% lower than O ₂ Upper)	14%	2.5%	5.5%	5.5%
	30%	2.5%	5.5%	5.5%
	40%	2.5%	5.5%	5.5%
	50%	2.5%	5.5%	5.5%
	70%	2.5%	5.5%	5.0%
	100%	2.5%	5.5%	4.5%
O ₂ Upper (must be at least 1% higher than O ₂ Lower)	14%	5.5%	8.5%	7.0%
	30%	5.5%	8.5%	7.8%
	40%	5.5%	8.5%	8.0%
	50%	5.5%	8.5%	7.5%
	70%	5.5%	8.5%	6.0%
	100%	5.5%	8.5%	5.5%
O ₂ Offset		-3.0	3.0	1.0

BMK3000 AERtrim Adjustment Range			
CALIBRATION POINT	BLOWER VOLTAGE		
	Minimum	Maximum	Default
14%	2.60	4.90	2.80
30%	3.60	7.00	4.60
40%	4.60	8.00	5.00
50%	5.00	9.20	5.50
70%	6.10	10.00	6.90
100%	7.60	10.00	9.10

SECTION 9 – AERTRIM OPERATION

BMK 4000 AERtrim Values				
MENU ITEM		Minimum	Maximum	Default
Settle Time		0	120 sec	20 sec
Trim Gain		0.1	5.0	0.250
Max Tries		0	100	15
O ₂ Target (must be between O ₂ Upper & O ₂ Lower)	23%	3	8	6.0
	30%	3	8	5.5
	40%	3	8	5.5
	50%	3	8	5.5
	70%	3	8	5.5
	100%	3	8	5.5
O ₂ Lower (must be at least 1% lower than O ₂ Upper)	23%	2.5	5.5	5.5
	30%	2.5	5.5	5.0
	40%	2.5	5.5	5.0
	50%	2.5	5.5	5.0
	70%	2.5	5.5	5.0
	100%	2.5	5.5	5.0
O ₂ Upper (must be at least 1% higher than O ₂ Lower)	23%	5.5	8.5	6.5
	30%	5.5	8.5	6.0
	40%	5.5	8.5	6.0
	50%	5.5	8.5	6.0
	70%	5.5	8.5	6.0
	100%	5.5	8.5	6.0
O ₂ Offset		-3.0	3.0	1.0

BMK4000 AERtrim Adjustment Range			
CALIBRATION POINT	BLOWER VOLTAGE		
	Minimum	Maximum	Default
23%	1.00	3.00	1.50
30%	2.10	5.40	2.35
40%	2.75	7.20	3.20
50%	2.90	7.65	3.55
70%	3.90	8.10	4.90
100%	5.00	8.55	6.90

BMK 5000 AERtrim Values				
MENU ITEM		Minimum	Maximum	Default
Settle Time		0	120 Sec	20 Sec
Trim Gain		0.1	5.0	0.250
Max Tries		0	100	15
O ₂ Target (must be between O ₂ Upper & O ₂ Lower)	18%	3%	8%	5.5%
	30%	3%	8%	5.5%
	45%	3%	8%	5.5%
	60%	3%	8%	5.5%
	80%	3%	8%	5.5%
O ₂ Lower Limit (must be at least 1% lower than O ₂ Upper)	100%	3%	8%	5.0%
	18%	2.5%	5.5%	4.5%
	30%	2.5%	5.5%	4.5%
	45%	2.5%	5.5%	4.5%
	60%	2.5%	5.5%	5.0%
O ₂ Upper Limit (must be at least 1% higher than O ₂ Lower)	80%	2.5%	5.5%	5.0%
	100%	2.5%	5.5%	4.5%
	18%	5.5%	8.5%	6.5%
	30%	5.5%	8.5%	6.5%
	45%	5.5%	8.5%	6.5%
O ₂ Offset	60%	5.5%	8.5%	6.0%
	80%	5.5%	8.5%	6.0%
	100%	5.5%	8.5%	5.5%
O ₂ Offset		-3.0	3.0	1.0

BMK 5000 AERtrim Adjustment Range			
CALIBRATION POINT	BLOWER VOLTAGE		
	Minimum	Maximum	Default
18%	No minimum or maximum for these calibration points.		2.05
30%			3.80
40%			4.50
50%	3.30	5.30	4.30
70%	3.80	5.80	4.80
100%	7.10	10.00	7.70

BMK 5000N AERtrim Values				
MENU ITEM		Minimum	Maximum	Default
Settle Time		0	120 sec	20 sec
Trim Gain		0.1	5.0	0.250
Max Tries		0	100	15
O ₂ Target (must be between O ₂ Upper & O ₂ Lower)	18%	3	8	6.0
	30%	3	8	5.5
	40%	3	8	5.5
	50%	3	8	5.5
	70%	3	8	5.5
O ₂ Lower (must be at least 1% lower than O ₂ Upper)	18%	2.5	5.5	5.5
	30%	2.5	5.5	5.0
	40%	2.5	5.5	5.0
	50%	2.5	5.5	5.0
	70%	2.5	5.5	5.0
O ₂ Upper (must be at least 1% higher than O ₂ Lower)	18%	5.5	8.5	6.5
	30%	5.5	8.5	6.0
	40%	5.5	8.5	6.0
	50%	5.5	8.5	6.0
	70%	5.5	8.5	6.0
O ₂ Offset		-3.0	3.0	1.0

BMK5000N AERtrim Adjustment Range			
CALIBRATION POINT	BLOWER VOLTAGE		
	Minimum	Maximum	Default
18%	1.00	2.00	1.32
30%	2.00	3.20	2.47
40%	2.90	5.20	3.70
50%	3.20	6.10	4.15
70%	3.80	7.20	4.70
100%	5.70	10.00	7.20

BMK 6000 AERtrim Values				
MENU ITEM		Minimum	Maximum	Default
Settle Time		0	120 Sec	20 Sec
Trim Gain		0.1	5.0	0.250
Max Tries		0	100	15
O ₂ Target (must be between O ₂ Upper & O ₂ Lower)	18%	3%	8%	5.5%
	30%	3%	8%	5.5%
	45%	3%	8%	5.5%
	60%	3%	8%	5.5%
	80%	3%	8%	5.5%
O ₂ Lower Limit (must be at least 1% lower than O ₂ Upper)	100%	3%	8%	5.0%
	18%	2.5%	5.5%	4.5%
	30%	2.5%	5.5%	4.5%
	45%	2.5%	5.5%	5.0%
	60%	2.5%	5.5%	5.0%
O ₂ Upper Limit (must be at least 1% higher than O ₂ Lower)	80%	2.5%	5.5%	5.0%
	100%	2.5%	5.5%	4.5%
	18%	5.5%	8.5%	6.5%
	30%	5.5%	8.5%	6.5%
	45%	5.5%	8.5%	6.0%
O ₂ Offset	60%	5.5%	8.5%	6.0%
	80%	5.5%	8.5%	6.0%
	100%	5.5%	8.5%	5.5%
O ₂ Offset		-3.0	3.0	1.0

BMK 6000 AERtrim Adjustment Range			
CALIBRATION POINT	BLOWER VOLTAGE		
	Minimum	Maximum	Default
18%	No minimum or maximum for these calibration points.		2.00
30%			2.00
40%			2.30
50%	2.55	3.55	2.60
70%	3.40	4.70	4.05
100%	7.10	10.00	8.60

9.6 AERtrim Maintenance and Troubleshooting

The AERtrim system depends on the O₂ sensor to maximize blower efficiency. The AERtrim system needs only minimal maintenance. It is recommended that you **inspect the oxygen sensor for accuracy every 12 months** by comparing it to a sensor reading from a properly calibrated flue analyzer. This is strongly advised because contaminated air or gas supplies may cause impurity buildup and shift the calibration point. An offset value of ±3.0% can be entered in the **O2 Offset** parameter in the **AERtrim Settings** screen (**Main Menu → Advanced Setup → Performance → AERtrim → AERtrim Settings**) to correct the reading during manual calibration. If the sensor has a large amount of offset, a replacement may be required soon.

Occasional software updates to the device may be required.

TABLE 9-1: AERtrim General Warnings		
Warning	Cause	Possible Solutions
O2 Percentage Low	O ₂ Levels less than 2% for more than 30 seconds (auto-reset when valve comes back in range)	Dirty filter or poor combustion calibration – recalibrate unit
		O ₂ Offset too low – Increase Offset value
		Bad Sensor-Replace
O2 Sensor Malfunction	O ₂ Levels less than -4% or more than 24% for more than 10 seconds {manual clearing of this fault is required}	Bad Sensor-Replace Communication Issue – check wires and connections
Warning O2 Level High	O ₂ Levels > 9% and < 24% for more than 30 seconds {auto-reset when value comes back in range}	Gas Pressure Regulator or Air Blower Problem, or bad Combustion Calibration
		O ₂ Offset too high
		Bad Sensor-Replace
O2 Sensor Out of Range	Sensor auto calibration offset required is more than ±3%	Reset Unit-Recalibrate Sensor
		Bad Sensor-Replace
		Bad ECU-Replace (Rare)
O2 Warning Service Required	If the O ₂ level is outside of its limits for more than 5 minutes. For example: 1) Reading < Lower Limit & Blower Voltage = BV Limit OR 2) Reading > Upper Limit & Blower Voltage = BV Limit	Gas Supply, Air Filter, or Air Blower issue
		Bad Sensor-Replace

The Edge Controller does not display a message when O₂ levels are within the target range. However, if O₂ levels fall outside the target range, one of the messages below will be displayed in the **AERtrim Status** parameter on the **Main Menu → Advanced Setup → Performance → AERtrim → AERtrim Status** screen.

TABLE 9-2: AERtrim Operation Interruption Errors		
Error Message	Cause	Possible Solutions
BV Hi Err	Trim operation exceeds allowable blower voltage limits	Check air filter, gas regulator, combustion calibration
BV Lo Err		Check sensor calibration: it may need to be replaced
Max Iter	Trim Operation reached maximum iteration. Wait and try again	Check sensor calibration for inaccuracies
		Increase gain or iteration attempts
Tmp Rng Err	Outlet temp outside range	None-Normal Operation
FR Rng Err	Fire Rate not within track range during trim operation	None – Steady State has not been achieved

SECTION 10: TROUBLESHOOTING

10.1 Introduction

This section is intended to aid service/maintenance personnel in isolating the cause of a fault in your Benchmark boiler. The procedures below are presented in tabular form on the following pages.

NOTE: All AERtrim troubleshooting messages are included in Section 9.6, above.

When a fault occurs in the unit, proceed as follows to isolate and correct the fault:

1. Observe the fault messages displayed on the Edge Controller.
2. Refer to the Fault Indication column in Troubleshooting Table 10-1, below, and locate the Fault that best describes the existing conditions.
3. Proceed to the Probable Cause column and start with the first item (1) listed for the Fault Indication.
4. Perform the checks and procedures listed in the Corrective Action column for the first Probable Cause candidate.
5. Continue checking each additional Probable Cause for the existing fault until the fault is corrected.
6. Section 10-2 contains additional troubleshooting information that may apply to situations in which no fault message is displayed.

If the fault cannot be corrected using the information provided in the Troubleshooting Tables, contact your local AERCO Representative.

SECTION 6 – TROUBLESHOOTING

TABLE 10-1: Boiler Troubleshooting Procedures		
Fault	Probable Causes	Corrective Action
AIRFLOW FAULT DURING IGNITION	Blower stopped running due to thermal or current overload.	Check combustion blower for excessive heat or high current drain that may trip thermal or current overload devices.
	Blocked Blower inlet or inlet air filter.	Inspect inlet to combustion blower including air filter at the air/fuel valve for blockage.
	Blockage in Blower Proof switch.	Remove the Blower Proof switch and inspect for signs of blockage, clean or replace as necessary.
	Blockage in Blocked Inlet switch.	Remove the Blocked Inlet switch and inspect for signs of blockage, clean or replace as necessary.
	Defective Blower Proof switch.	Check the continuity of the Blower Proof switch with the combustion blower running. If there is an erratic resistance reading or the resistance reading is greater than zero ohms, replace the switch.
	Defective Blocked Inlet switch.	Turn off unit and check the continuity of the Blocked Inlet switch. If there is an erratic resistance reading or the resistance reading is greater than zero ohms, replace the switch.
	Bad inlet air temperature sensor.	Check actual inlet air temperature and measure resistance at Sensor Harness connection P1. Verify reading conforms to values in Section 2 of the <i>Benchmark -Edge: REFERENCE Manual (OMM-0138)</i> .
	Defective temperature sensor.	Check actual inlet air temperature and measure resistance at Sensor Harness connection P1. Verify reading conforms to values in Section 2 of the <i>Benchmark -Edge: REFERENCE Manual (OMM-0138)</i> .
	Loose wire between Blower and Controller.	Check wire connection from the Blower motor to the Secondary Power Panel.
	Defective Air-Fuel Valve potentiometer.	Check Air/Fuel Valve position at 0%, 50% and 100% open positions. The positions on the Valve Position bar graph should match the readings on the Air/Fuel Valve dial.
Hard light.	Check igniter-injector for soot or erosion. Check injector solenoid valve open/close operation.	
AIRFLOW FAULT DURING PURGE	Blower not running or running too slow.	If blower doesn't run, check solid state relay for voltage. If OK, check blower.
	Defective Blocked Inlet switch.	If blower runs, check blocked Inlet switch for continuity. Replace switch if no continuity.
	Blockage in air filter or Blocked Inlet switch.	Remove air filter and Blocked Inlet switch and inspect for blockage. Clean or replace as necessary.
	Blocked blower inlet or inlet ductwork.	Inspect inlet to combustion blower including any ductwork leading to blower for blockage.
	No voltage to Blocked Inlet switch from Edge Controller.	During start sequence, verify that 24 VAC is present between each side of the switch and ground. If 24 VAC is not present, refer fault to qualified service personnel.
Missing/disconnected Blocked Flue jumper.	Check auxiliary box to be sure Blocked Flue input is jumpered and properly connected.	
AIRFLOW FAULT DURING RUN	Thermal or current overload.	Check blower for excessive heat or high current draw that may trip or overload devices.
	Blocked Blower inlet or inlet ductwork.	Inspect inlet to blower, including any ductwork leading up to the combustion blower, for blockage.
	Blockage in air filter or Blocked Inlet switch.	Remove air filter and Blocked Inlet switch and inspect for blockage; clean or replace as necessary.
	Defective Blocked Inlet switch.	Verify 24 VAC is present between each side of switch and ground. If not present, replace switch.
	Combustion oscillations.	Run unit to full fire. If the unit rumbles or runs rough, perform combustion calibration.

SECTION 6 – TROUBLESHOOTING

TABLE 10-1: Boiler Troubleshooting Procedures		
Fault	Probable Causes	Corrective Action
DELAYED INTERLOCK OPEN	Delayed Interlock Jumper not installed or missing.	Ensure jumper is properly installed across the Delayed Interlock terminals in the I/O Box.
	Device proving switch hooked to interlocks is not closed.	If there are 2 external wires on these terminals, check if an end switch for a proving device (such as a pump, louver, etc.) is tied to the interlocks. Ensure the device and/or its end switch is functional. A jumper may be temporarily installed to test the interlock.
DIRECT DRIVE SIGNAL FAULT	Direct drive signal is not present: Not yet installed. Wrong polarity. Signal defective at source. Broken or loose wiring.	Check I/O Box to ensure signal is hooked up. Hook up if not installed. If installed, check polarity. Measure signal level. Check wiring continuity between source and unit.
	Signal is not isolated (floating).	Check signal at source to ensure it is isolated.
	Signal type selection switches not set for correct signal type (voltage or current).	Check DIP switch on Controller’s Interface board is set correctly for the type of signal being sent. Check control signal type set in Advanced Setup → BST Cascade → Application Configuration screen.
FLAME LOSS DURING IGN	Worn Flame Detector.	Remove and inspect the Flame Detector for signs of wear. Replace if necessary.
	No spark from Spark Igniter.	Close the internal gas valve in the unit. Install and arc a spark igniter outside the unit.
	Defective Ignition Transformer.	If there is no spark, check for 120VAC at the primary side to the ignition transformer during the ignition cycle.
	Defective Ignition/Stepper (IGST) Board.	If 120VAC is not present, the IGST Board in the Edge Controller may be defective. Refer fault to qualified service personnel.
	Defective SSOV.	While externally arcing the spark igniter, ensure that open/close indicator in the Safety Shut-Off Valve is opening. If valve does not open, check for 120VAC at valve input terminals. If 120VAC isn’t present, the Edge Controller’s IGST board may be defective. Refer fault to qualified service personnel.
FLAME LOSS DURING RUN	Worn Flame Detector or cracked ceramic.	Remove and inspect the Flame Detector for signs of wear or cracked ceramic. Replace if necessary.
	Defective Regulator.	Check gas pressure readings using a gauge or manometer into and out of the Air/Fuel Valve to ensure that the gas pressure into and out of the valve is correct.
	Poor combustion calibration.	Check combustion calibration using procedures in Section 4.5 of this guide.
	Debris on burner.	Remove burner and inspect for any carbon build-up or debris. Clean and reinstall.
	Blocked condensate drain.	Remove blockage in condensate drain.

SECTION 6 – TROUBLESHOOTING

TABLE 10-1: Boiler Troubleshooting Procedures		
Fault	Probable Causes	Corrective Action
HEAT DEMAND FAILURE	Heat Demand Relays on Ignition/Stepper board failed to activate when commanded.	Press CLEAR button and restart the unit. If the fault persists, replace Ignition/Stepper (IGST) Board.
	Relay is activated when not in Demand.	Defective relay. Replace IGST Board.
HIGH EXHAUST TEMPERATURE	Poor combustion calibration.	Check combustion calibration using procedures in Section 4.4: <i>Combustion Calibration</i> of this guide.
	Carboned heat exchanger due to incorrect combustion calibration.	If exhaust temperature is greater than 200° F (93.3°C), check combustion calibration. Calibrate or repair as necessary.
HIGH GAS PRESSURE	Incorrect supply gas pressure.	Check to ensure gas pressure at inlet of SSOV does not exceed 14" W.C. (3.49 kPa) .
	Defective SSOV Actuator.	If gas supply pressure downstream of SSOV Actuator cannot be lowered to the range specified in Table 4-1 (Natural Gas) or Table 4-4 (Propane) in Section 4.4; the SSOV Actuator may be defective.
	Defective High Gas Pressure switch.	Remove the leads from the High Gas Pressure switch. Measure continuity across the common (C) and normally closed (NC) terminals with the unit not firing. Replace the switch if continuity does not exist.
HIGH WATER TEMP SWITCH OPEN	Faulty Water temperature switch.	Test the temperature switch to insure it trips at its actual water temperature setting.
	Incorrect PID settings.	Check PID settings (Advanced Setup → Performance → Temperature Control , first 3 items). If the settings have been changed, record the current readings then reset to default values.
	Faulty shell temperature sensor.	Using the resistance charts in Section 2 of the <i>Benchmark -Edge: REFERENCE Manual</i> (OMM-0138) measure the resistance of Shell sensor and BTU sensor at a known water temperature.
	Unit is in Manual mode.	Switch to Auto mode (Diagnostic → Manual Run , set Manual Mode = Enabled).
	Unit setpoint is greater than Over Temperature switch setpoint.	Check setpoint of unit and setpoint of Temperature switch; Ensure that the temperature switch is set higher than the unit's setpoint.
	System flow rate changes are occurring faster than units can respond.	If the system is a variable flow system, monitor system flow changes to ensure that the rate of flow change is not faster than what the units can respond to.
HIGH WATER TEMPERATURE	See HIGH WATER TEMPERATURE SWITCH OPEN.	See HIGH WATER TEMPERATURE SWITCH OPEN.
	Temp HI Limit setting is too low.	Check Temp HI Limit setting.
IGN BOARD COMM FAULT	Communication fault occurred between PMC board and Ignition/Stepper board.	Press CLEAR button and restart the unit. If fault persists, contact qualified Service Personnel.
	32 Pin Ribbon cable defective.	Replace 32 Pin Ribbon cable.

SECTION 6 – TROUBLESHOOTING

TABLE 10-1: Boiler Troubleshooting Procedures		
Fault	Probable Causes	Corrective Action
IGN SWITCH CLOSED DURING PURGE	Air/Fuel Valve not rotating.	Start the unit. The Air/Fuel Valve should rotate to the purge (open) position. If the valve does not rotate at all or does not rotate fully open, check the Air/Fuel Valve calibration. If calibration is okay, the problem may be in the Air-Fuel Valve or the Edge Controller. Refer to qualified service personnel.
	Defective or shorted switch.	If Air/Fuel Valve rotates to purge, check ignition switch for continuity between the N.O. and COM terminals. If switch shows continuity when not in contact with the cam replace the switch.
	Switch wired incorrectly.	Ensure switch is wired correctly (correct wire numbers on the normally open terminals). If wired correctly, replace the switch.
	Defective Power Supply Board or fuse.	Check DS1 & DS2 LEDs on Power Supply Board. If not steady ON , replace Power Supply Board.
	Defective IGST Board.	Check “Heartbeat” LED DS1 and verify it is blinking ON & OFF every second. If not, replace IGST Board.
IGN SWTCH OPEN DURING IGNITION	Air/Fuel Valve not rotating to ignition position.	Start the unit. The Air/Fuel Valve should rotate to the purge (open) position, then back to ignition position (towards closed) during the ignition cycle. If the valve does not rotate back to the ignition position, check the Air/Fuel Valve calibration. If calibration is okay, the problem may be in the Air/Fuel Valve or the Controller. Refer fault to qualified service personnel.
	Defective Ignition switch.	If the Air/Fuel Valve does rotate to the ignition position, check the ignition position switch for continuity between the N.O. and COM terminals when in contact with the cam.
	Defective Power Supply Board or fuse.	Check DS1 & DS2 LEDs on Power Supply Board. If not steady ON, replace Power Supply Board.
	Defective IGST Board.	Check “Heartbeat” LED DS1 and verify it is blinking ON & OFF every second. If not, replace IGST Board.
INTERLOCK OPEN	Interlock jumper not installed or removed.	Check for a jumper properly installed across the interlock terminals in the I/O box.
	Energy Management System does not have unit enabled.	If there are two external wires on terminals, check any Energy Management system to see if units are disabled (a jumper may be temporarily installed to see if the interlock circuit is functioning).
	Device proving switch hooked to interlocks is not closed.	Check that proving switch for any device hooked to the interlock circuit is closing and that the device is operational.
LINE VOLTAGE OUT OF PHASE	Line and Neutral switched in AC Power Box.	Check hot and neutral in AC Power Box to ensure they are not reversed.
	Incorrect power supply transformer wiring.	Check transformer wiring, in AC Power Box, against the power box transformer wiring diagram to ensure it is wired correctly.
LOW GAS PRESSURE	Incorrect supply gas pressure.	Measure gas pressure upstream of the SSOV Actuator(s) with the unit firing. Ensure it is above the value in Table 4-2 (Natural Gas) or Table 4-5 (Propane).

SECTION 6 – TROUBLESHOOTING

TABLE 10-1: Boiler Troubleshooting Procedures		
Fault	Probable Causes	Corrective Action
	Defective Low Gas Pressure switch.	Measure gas pressure at the Low Gas Pressure switch. If it is greater than 1 inch above the Low Gas Pressure switch setting in Table 4-2 (Natural Gas) or Table 4-5 (Propane), measure continuity across the switch and replace if necessary.
LOW WATER LEVEL	Insufficient water level in system.	Check system for sufficient water level.
	Defective water level circuitry.	Test water level circuitry using the Low Water TEST and RESET buttons on the Controller’s front panel. Replace water level circuitry if it does not respond.
	Defective water level probe.	Check continuity of probe end to the shell, change probe if there is no continuity.
MODBUS COMMFAULT	Unit not seeing information from Modbus network.	Check network connections. If fault persists, contact qualified Service Personnel.
PRG SWTCH CLOSED DURING IGNITION	A/F Valve rotated open to purge and did not rotate to ignition position.	Start the unit. The Air/Fuel Valve should rotate to the purge (open) position, then back to ignition position (towards closed) during the ignition cycle. If the valve does not rotate back to the ignition position, check the Air/Fuel Valve calibration. If calibration is okay, the problem may be in the Air/Fuel Valve or the Edge Controller. Refer fault to qualified service personnel.
	Defective or shorted switch.	If the Air/Fuel Valve does rotate to the ignition position, check the purge switch for continuity between the N.O. and COM terminals. If the switch shows continuity when not in contact with the cam, check to ensure that the switch is wired correctly (correct wire numbers on the normally open terminals).
	Switch wired incorrectly.	If the switch is wired correctly, replace the switch.
	Defective Power Supply Board or fuse.	Check DS1 & DS2 LEDs on Power Supply Board. If they are not steady ON, replace Power Supply Board.
	Defective IGST Board.	Check “Heartbeat” LED DS1 and verify it is blinking ON & OFF every second. If not, replace IGST Board.
PRG SWTCH OPEN DURING PURGE	Defective Purge switch.	If the air-fuel valve does rotate, check Purge switch for continuity when closing. Replace switch if continuity does not exist.
	No voltage present at switch.	Measure for 24 VAC from each side of the switch to ground. If 24VAC is not present, refer fault to qualified service personnel.
	Switch wired incorrectly.	Ensure the switch is wired correctly (correct wire numbers on the normally open terminals).
	Defective Power Supply Board or fuse.	Check DS1 & DS2 LEDs on Power Supply Board. If not steady ON, replace Power Supply Board.
	Defective IGST Board.	Check “Heartbeat” LED DS1 and verify it is blinking ON & OFF every second. If not, replace IGST Board.

SECTION 6 – TROUBLESHOOTING

TABLE 10-1: Boiler Troubleshooting Procedures		
Fault	Probable Causes	Corrective Action
OUTDOOR TEMP SENSOR FAULT	Loose or broken wiring.	Inspect Outdoor Temperature sensor for loose or broken wiring.
	Defective Sensor.	Check resistance of sensor to determine if it is within specification.
	Incorrect Sensor.	Ensure that the correct sensor is installed.
RECIRC PUMP FAILURE	Internal recirculation pump failed.	1. Replace recirculation pump.
REMOTE SETPT SIGNAL FAULT	Remote setpoint signal not present: Not yet installed. Wrong polarity. Signal defective at source. Broken or loose wiring.	Check I/O Box to ensure signal is hooked up. Hook up if not installed. If installed, check polarity. Measure signal level. Check continuity of wiring between source and unit.
	Signal is not isolated (floating) if 4 to 20 mA.	Check signal at source to ensure it is isolated.
	Edge Controller signal type selection switches not set for correct signal type (voltage or current).	Check DIP switch on PMC board to ensure it is set correctly for signal being sent. Check control signal type set in the Remote Signal parameter (Advanced Setup → Unit → Application Configuration).
RESIDUAL FLAME	Defective Flame Detector.	Replace Flame Detector.
	SSOV not fully closed.	Check open/close indicator window of Safety Shut-Off Valve (SSOV) and ensure that the SSOV is fully closed. If not fully closed, replace the valve and or actuator. Close Gas Shut-Off Valve downstream of SSOV. Install manometer or gauge at leak detection port between SSOV and Shut Off Valve. If gas pressure reading is observed, replace SSOV Valve/Actuator.
	Wire strand from burner head in contact with Flame Detector	Ensure Flame Detector is in good condition and is not tilted inward toward burner head.
SSOV FAULT DURING PURGE	See SSOV SWITCH OPEN	
SSOV FAULT DURING RUN	SSOV switch closed for 15 seconds during run.	Replace actuator.
SSOV RELAY FAILURE	SSOV relay failed on IGST board.	Press CLEAR button and restart unit. If fault persists, replace Ignition/Stepper (IGST) Board.
	Floating Neutral.	Neutral and Earth Ground are not connected at source and therefore there is a voltage measured between the two. Normally this measurement should be near zero or no more than a few millivolts.

SECTION 6 – TROUBLESHOOTING

TABLE 10-1: Boiler Troubleshooting Procedures		
Fault	Probable Causes	Corrective Action
	Hot and Neutral reversed at SSOV.	Check SSOV power wiring.
SSOV SWITCH OPEN	Actuator not allowing full gas valve closure.	Observe operation of the Safety Shut-Off Valve (SSOV) through indicator on the Valve actuator and ensure that the valve is fully and not partially closing.
	SSOV powered when it should not be	If the SSOV never closes, it may be powered continuously. Close the gas supply and remove power from the unit. Refer fault to qualified service personnel.
	Defective switch or Actuator.	Remove the electrical cover from the SSOV and check switch continuity. If the switch does not show continuity with the gas valve closed, either adjust or replace the switch or actuator.
	Incorrectly wired switch.	Ensure that the SSOV Proof of Closure switch is correctly wired.
STEPPER MOTOR FAILURE	Air/Fuel Valve unplugged.	Check that the Air/Fuel Valve is connected to the Edge Controller.
	Loose wiring connection to the stepper motor.	Inspect for loose connections between the Air/Fuel Valve motor and the wiring harness.
	Defective Air/Fuel Valve stepper motor.	Replace stepper motor.
	Defective Power Supply Board or fuse.	Check DS1 & DS2 LEDs on Power Supply Board. If they are not steady ON, replace Power Supply Board.
	Defective IGST Board.	Check “Heartbeat” LED DS1 and verify it is blinking ON & OFF every second. If not, replace IGST Board.
	Air/Fuel Valve out of calibration	Perform the stepper motor calibration procedure (Main Menu → Diagnostics → Subsystems → Air Fuel Valve Stepper Motor).

10.2 Additional Faults Without Specific Fault Messages

Refer to Table 10-2 to troubleshoot faults which may occur without a specific fault message being displayed.

TABLE 10-2: Boiler Troubleshooting with No Fault Message Displayed		
Observed Incident	Probable Causes	Corrective Action
Hard Light-Off	Clogged/damaged Gas Injector on Igniter-Injector (Figure 8-1).	Disconnect the Staged Ignition Assembly solenoid from the Gas injector Tube of the Igniter-Injector and inspect Gas Injector.
	Defective Staged Ignition Solenoid (Figure 8-1a through Figure 8-1c).	Close the Manual Shutoff Valve. Attempt to start the unit and listen for a “clicking” sound that the Staged Ignition Solenoid makes during Ignition Trial. If “clicking” sound is not heard after 2 or 3 attempts, replace the Staged Ignition Solenoid.
Fluctuating Gas Pressure	Gas pressure into unit is fluctuating.	Stabilize gas pressure going into unit; troubleshoot Building Supply Regulator.
	Damping Orifice not installed.	Check if the gas train is supposed to have a Damping Orifice, and if so, ensure that it is installed in the SSOV Actuator, as shown in Figure 10-1, below. For DBB Gas Trains, the Damping Orifice is installed in the downstream SSOV Actuator).

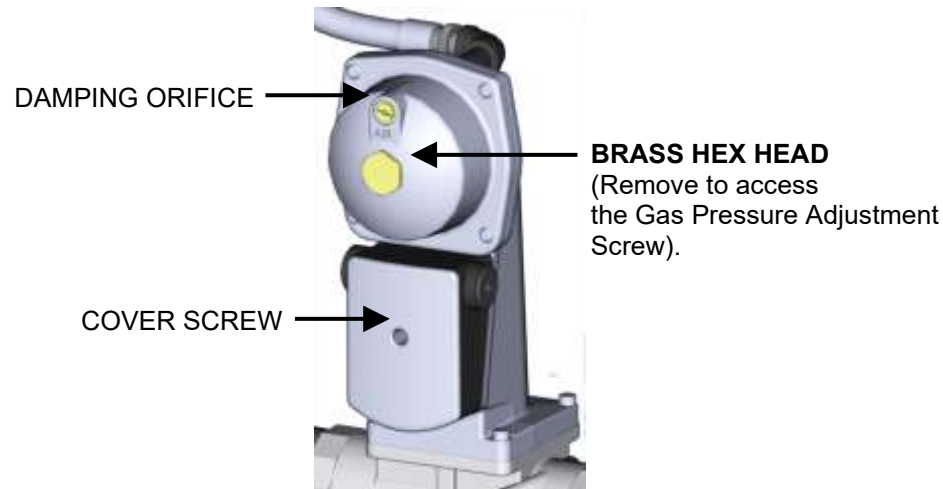
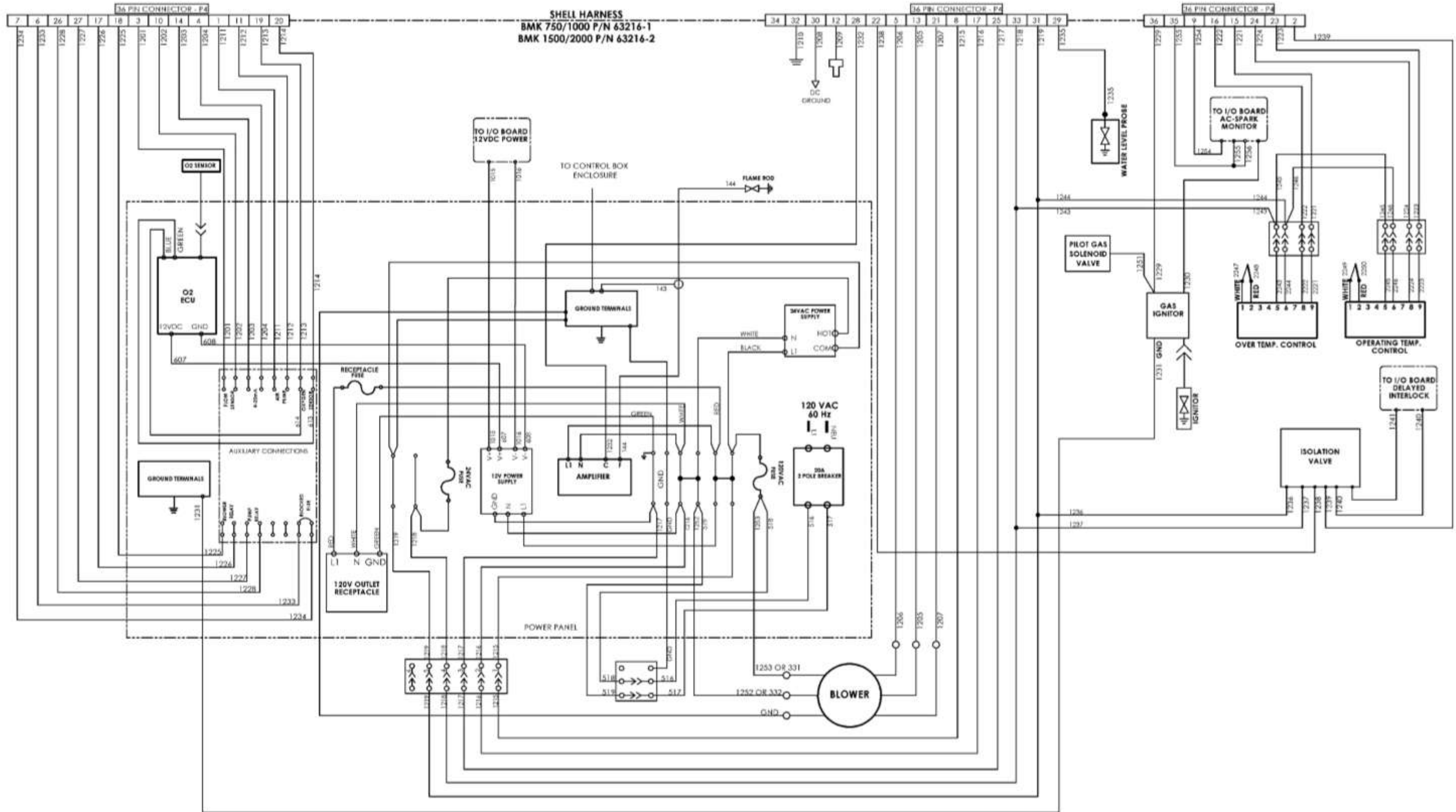

Figure 10-1: SSOV Actuator with Gas Pressure Adjustment (SKP25)

SECTION 11: WIRING DIAGRAMS

11.1 Benchmark 750 – 2000 Schematics



Benchmark 750 – 2000 – Drawing Number: 68094 rev B Sheet 1 of 4

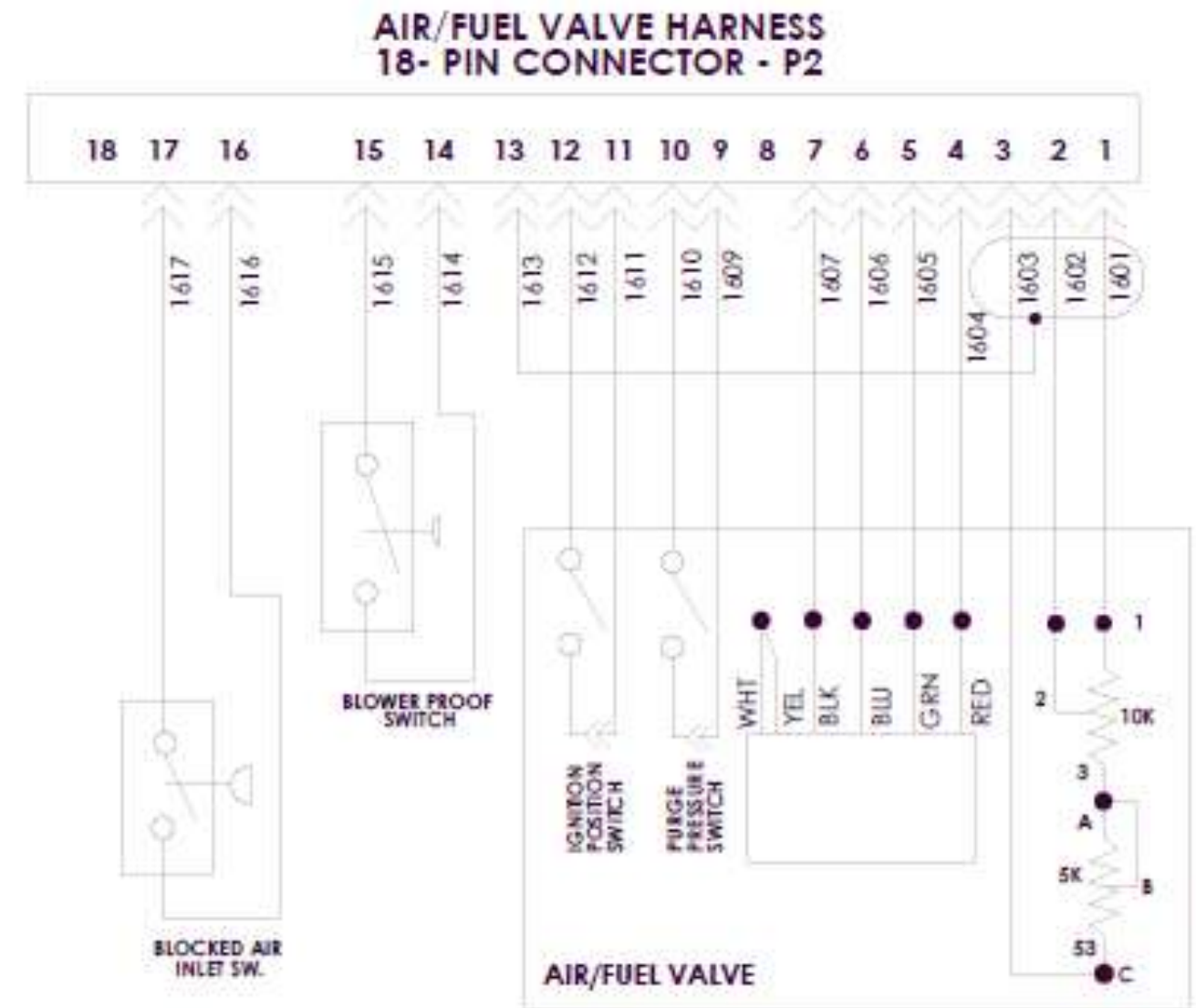
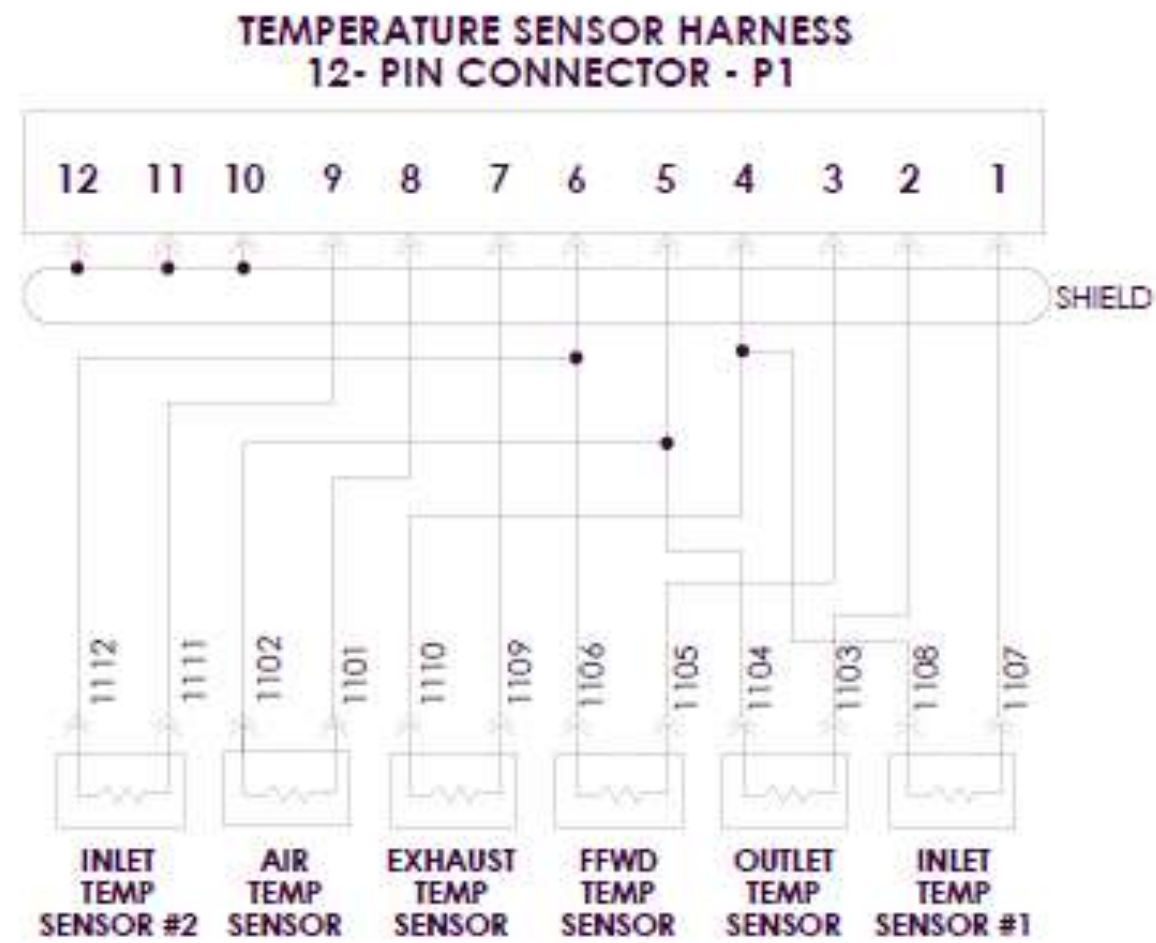

Benchmark 750 – 2000 – Drawing Number: 68094 rev B Sheet 2 of 4

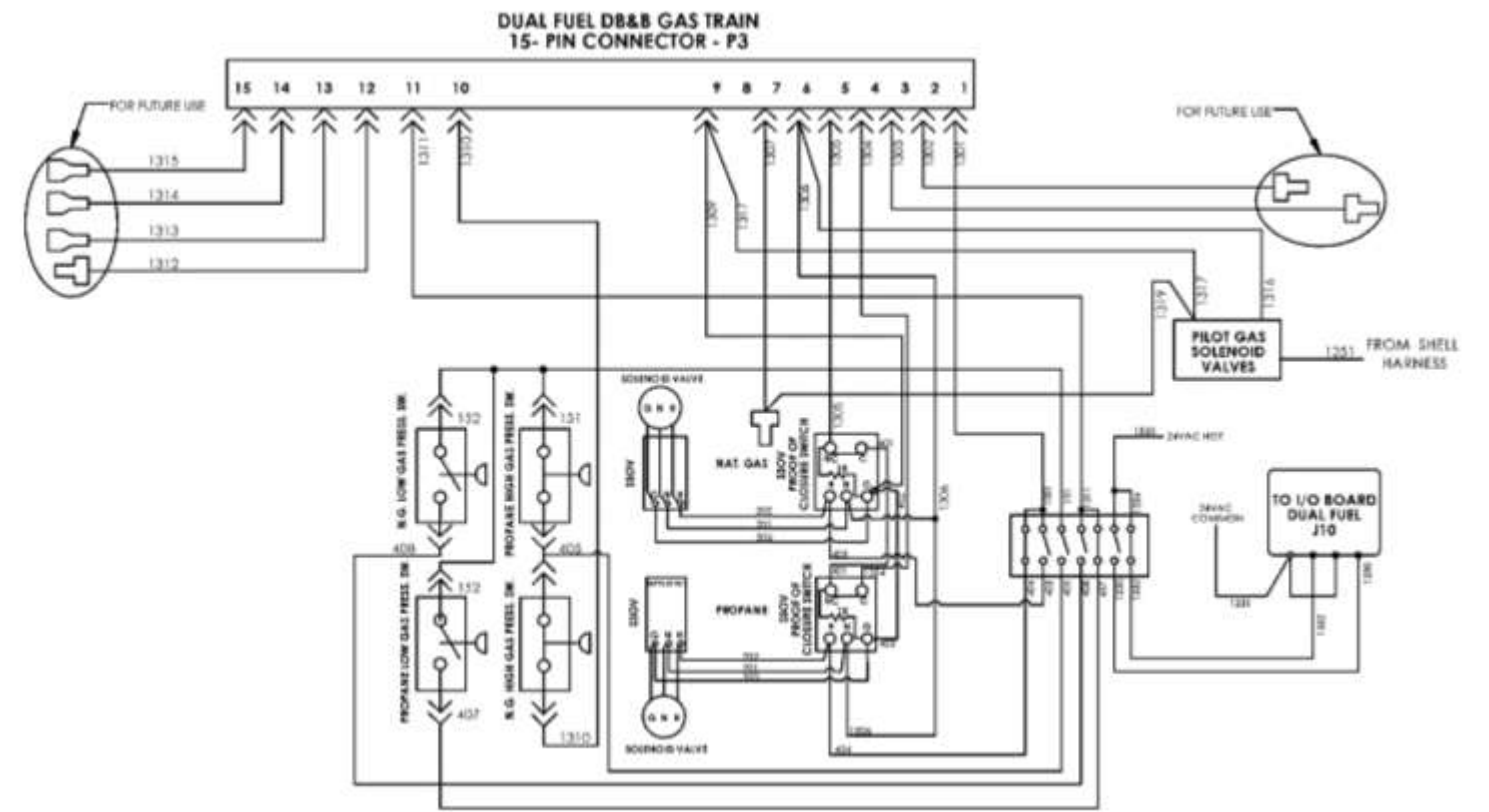
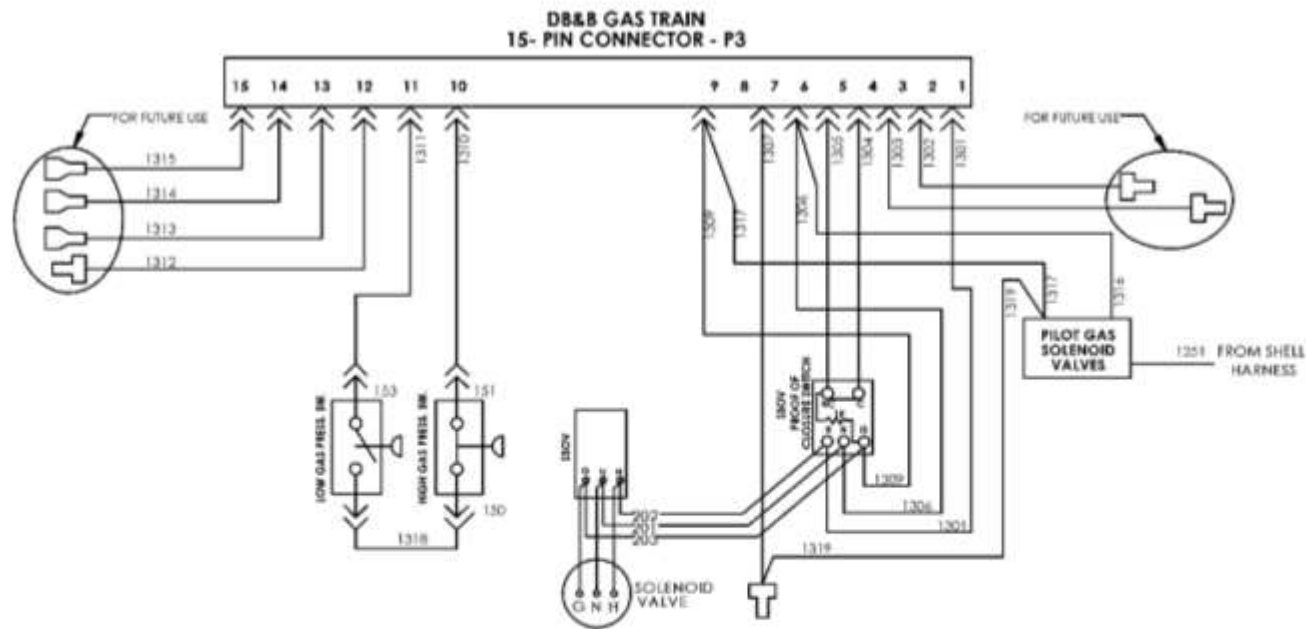
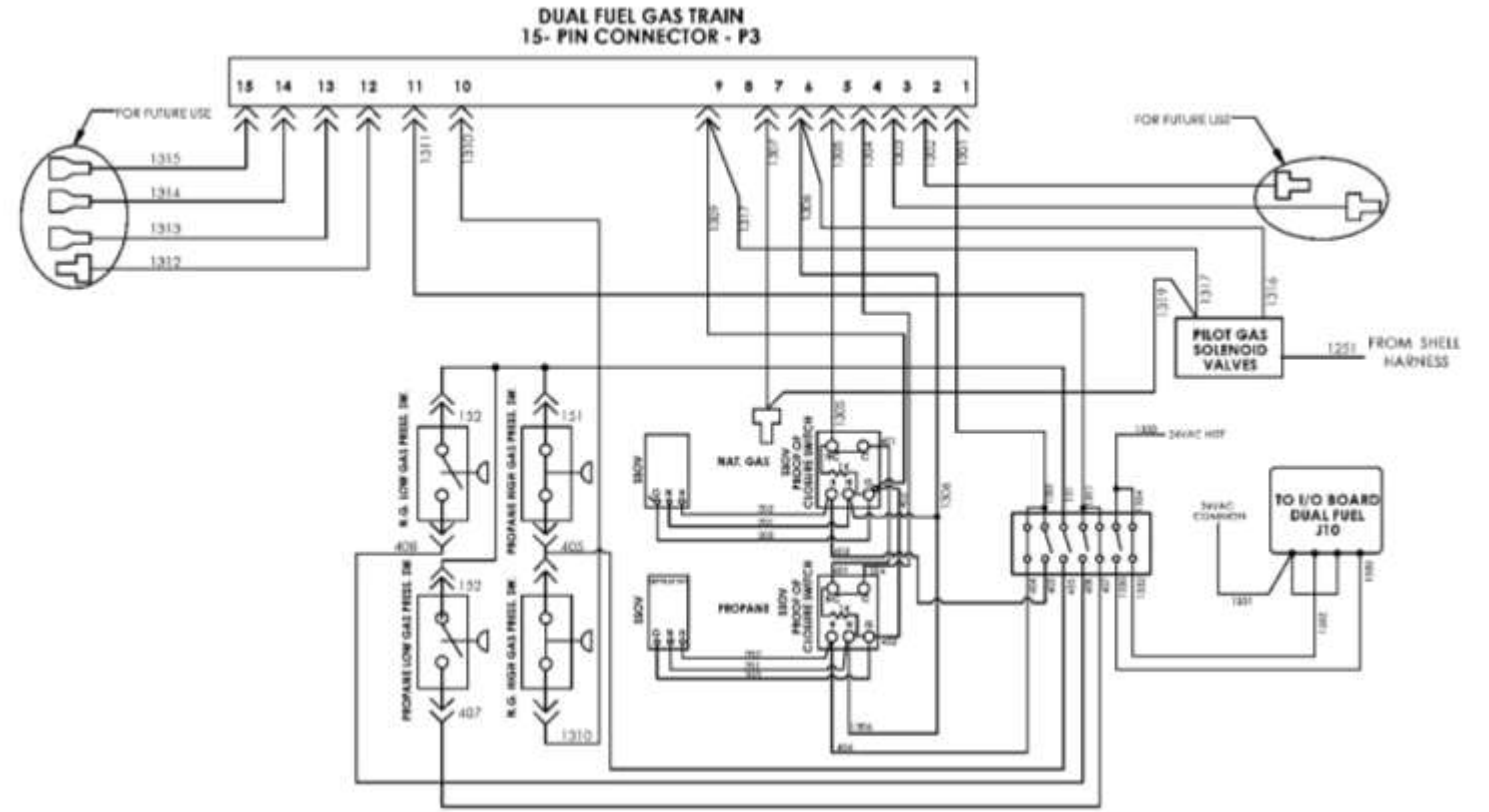
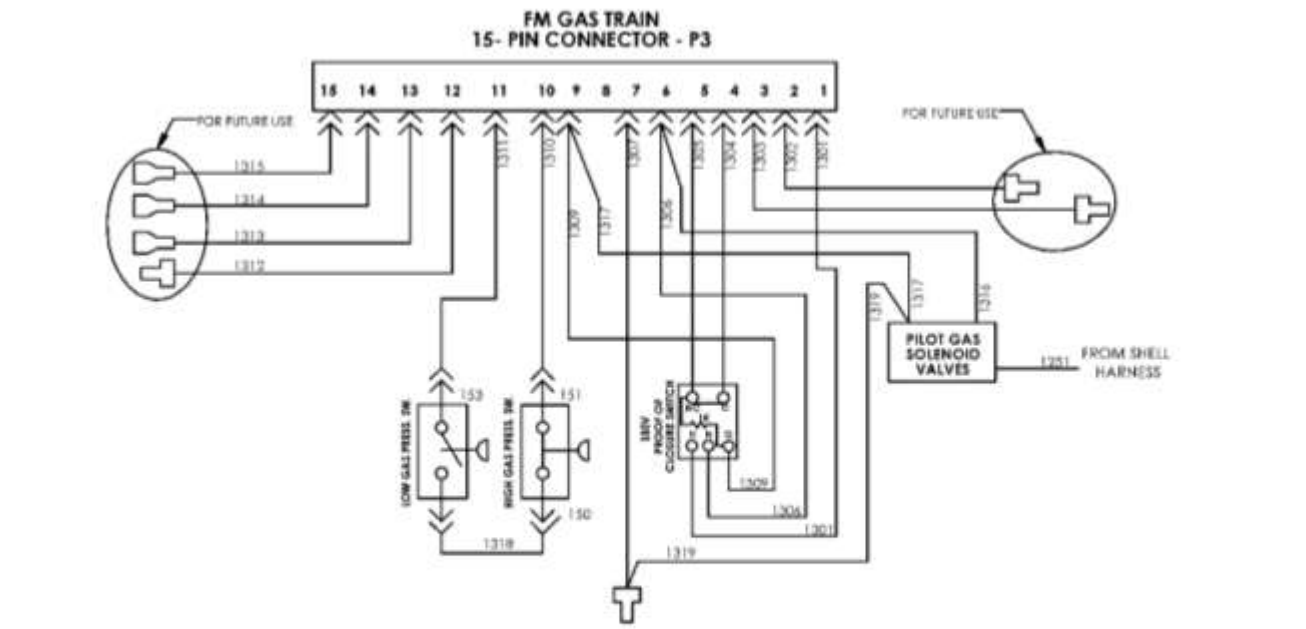

Benchmark 750 – 2000 – Drawing Number: 68094 rev B Sheet 3 of 4

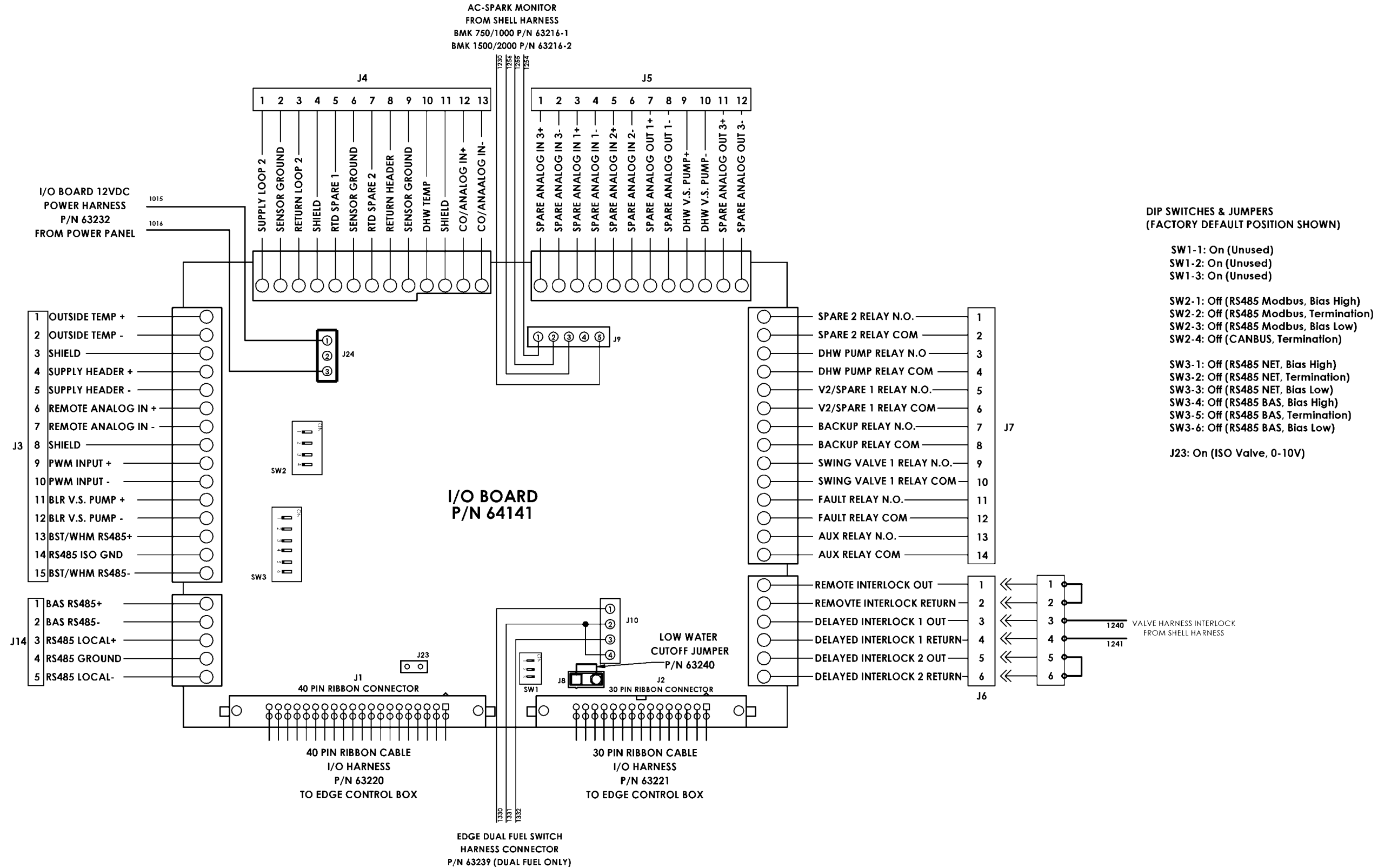

Benchmark 750 – 2000 – Drawing Number: 68094 rev B Sheet 4 of 4

11.2 Benchmark 2500 – 3000 Schematics

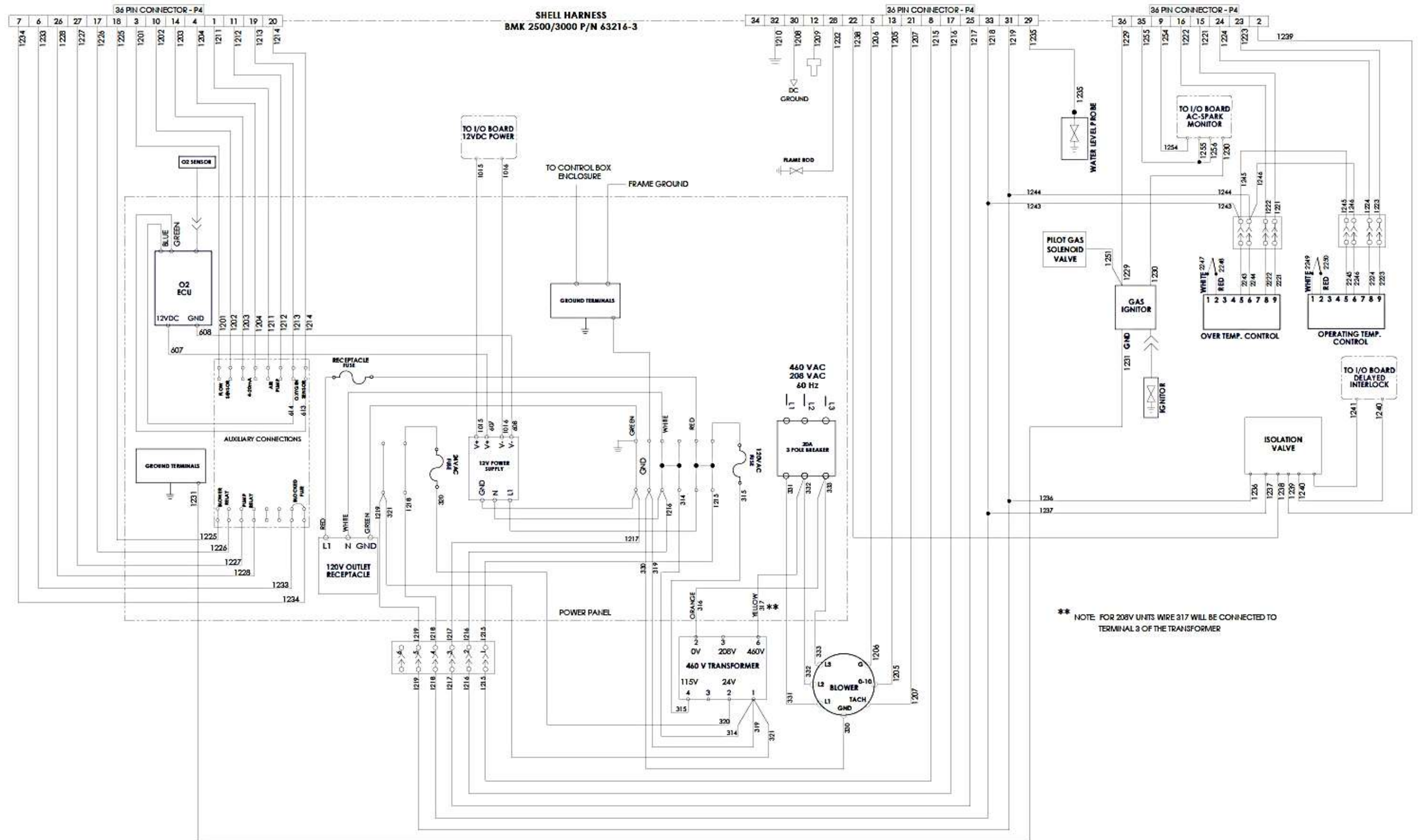

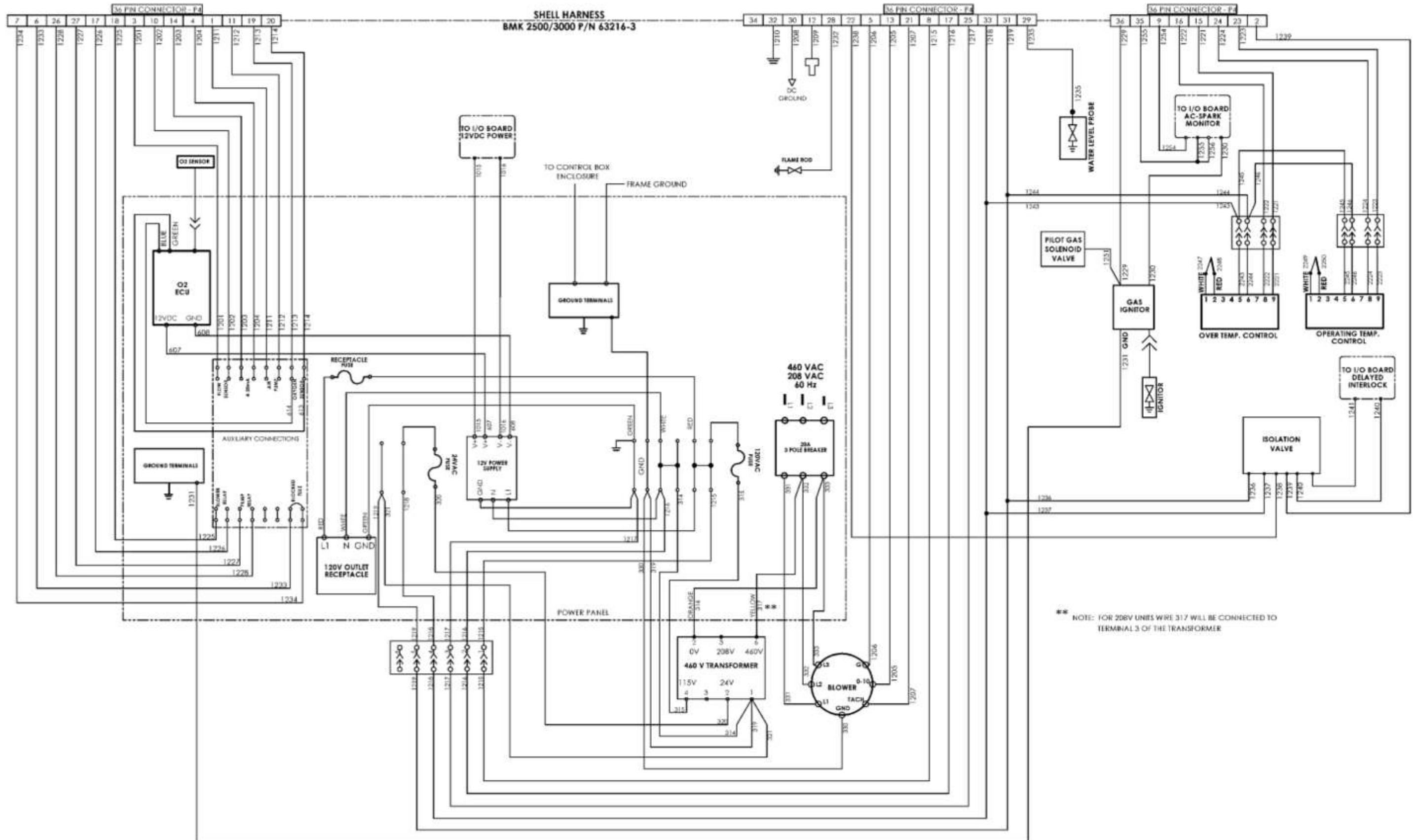

Benchmark 2500 – 3000 – Drawing Number: 68095 rev B Sheet 1 of 4

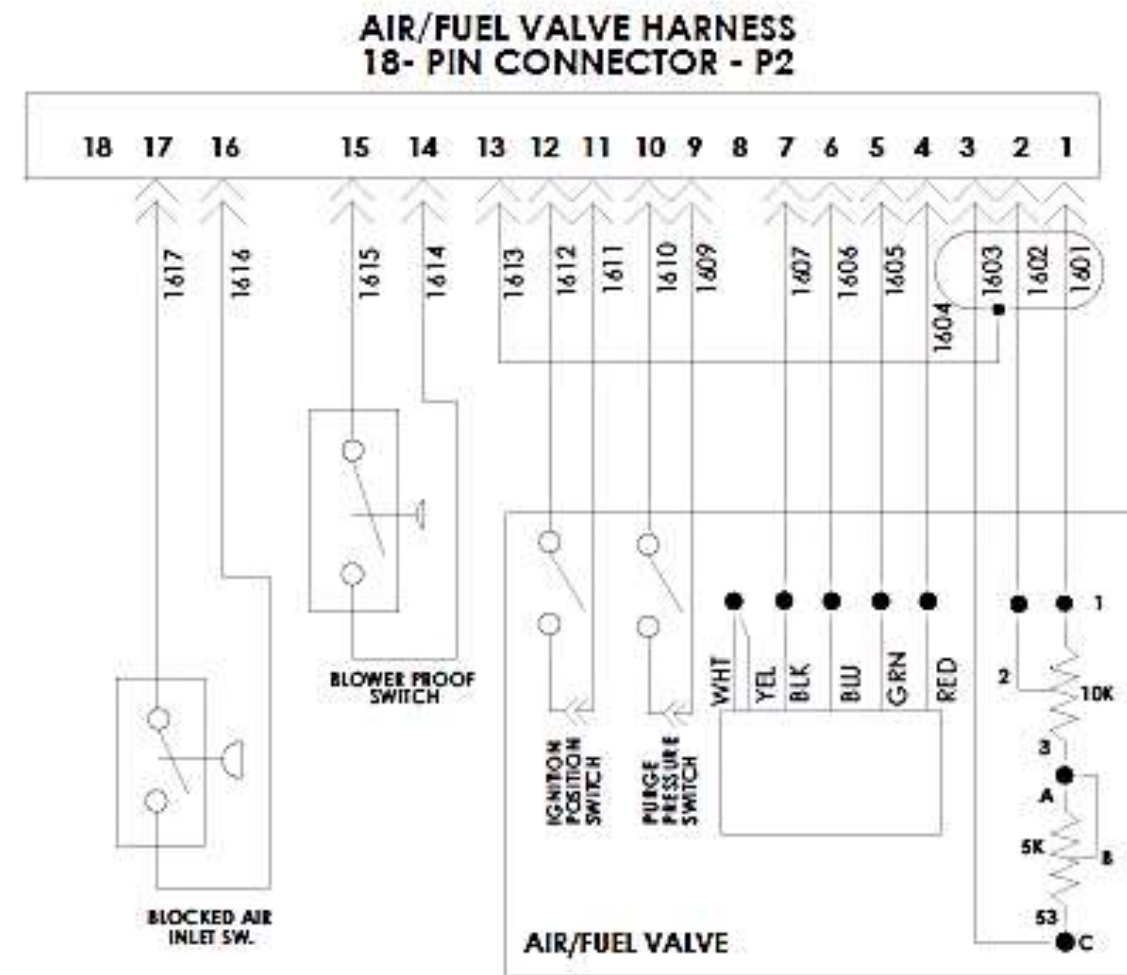
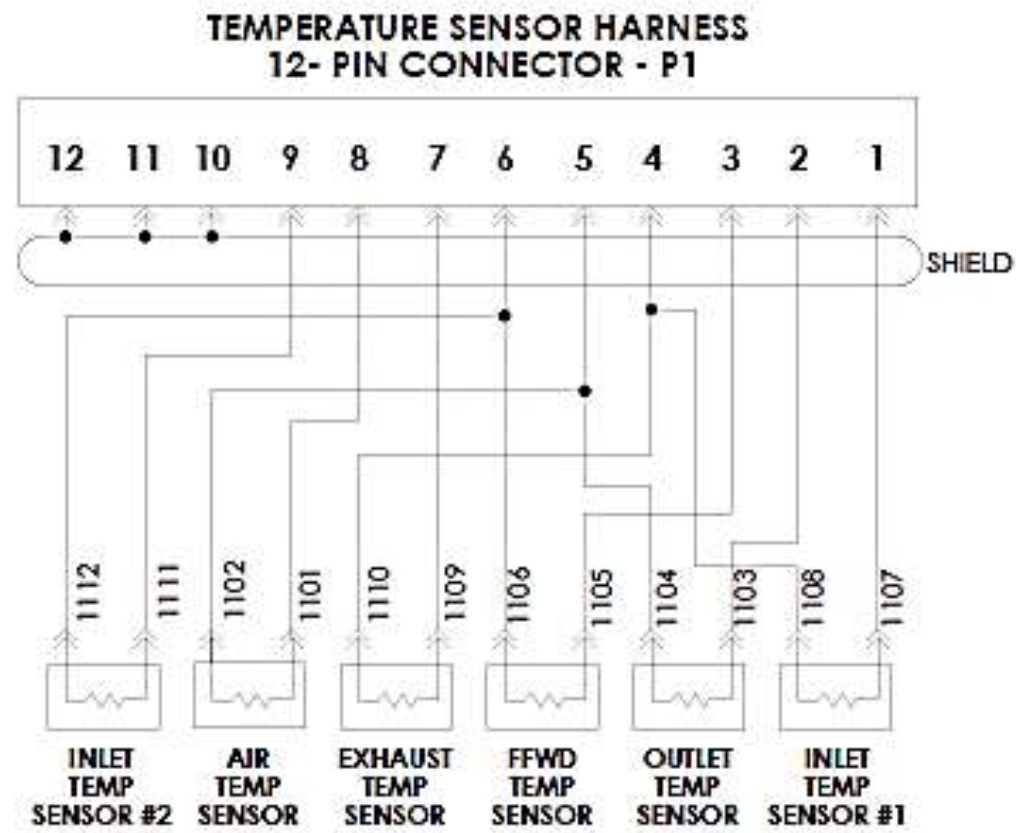

Benchmark 2500 – 3000 – Drawing Number: 68095 rev B Sheet 2 of 4

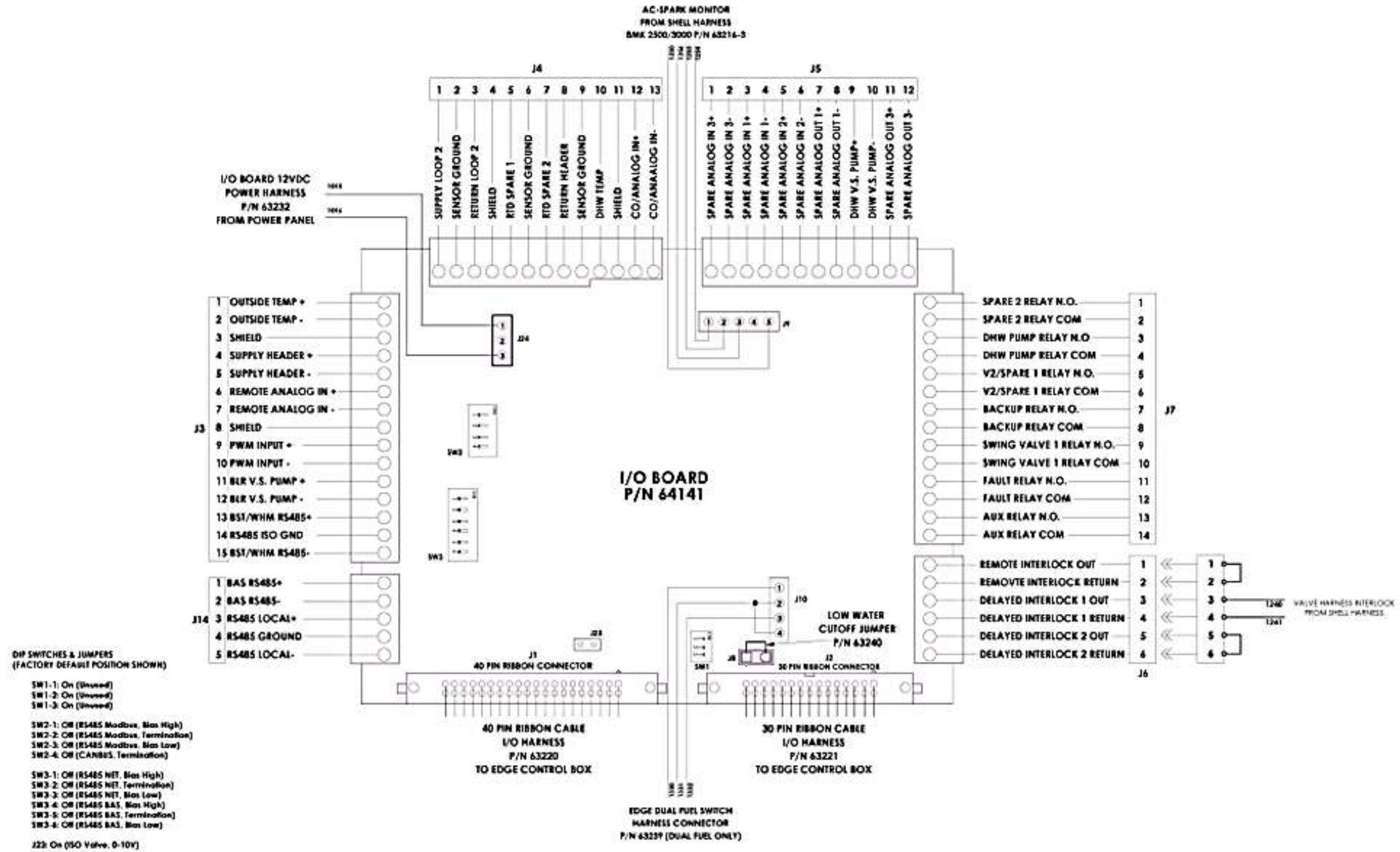

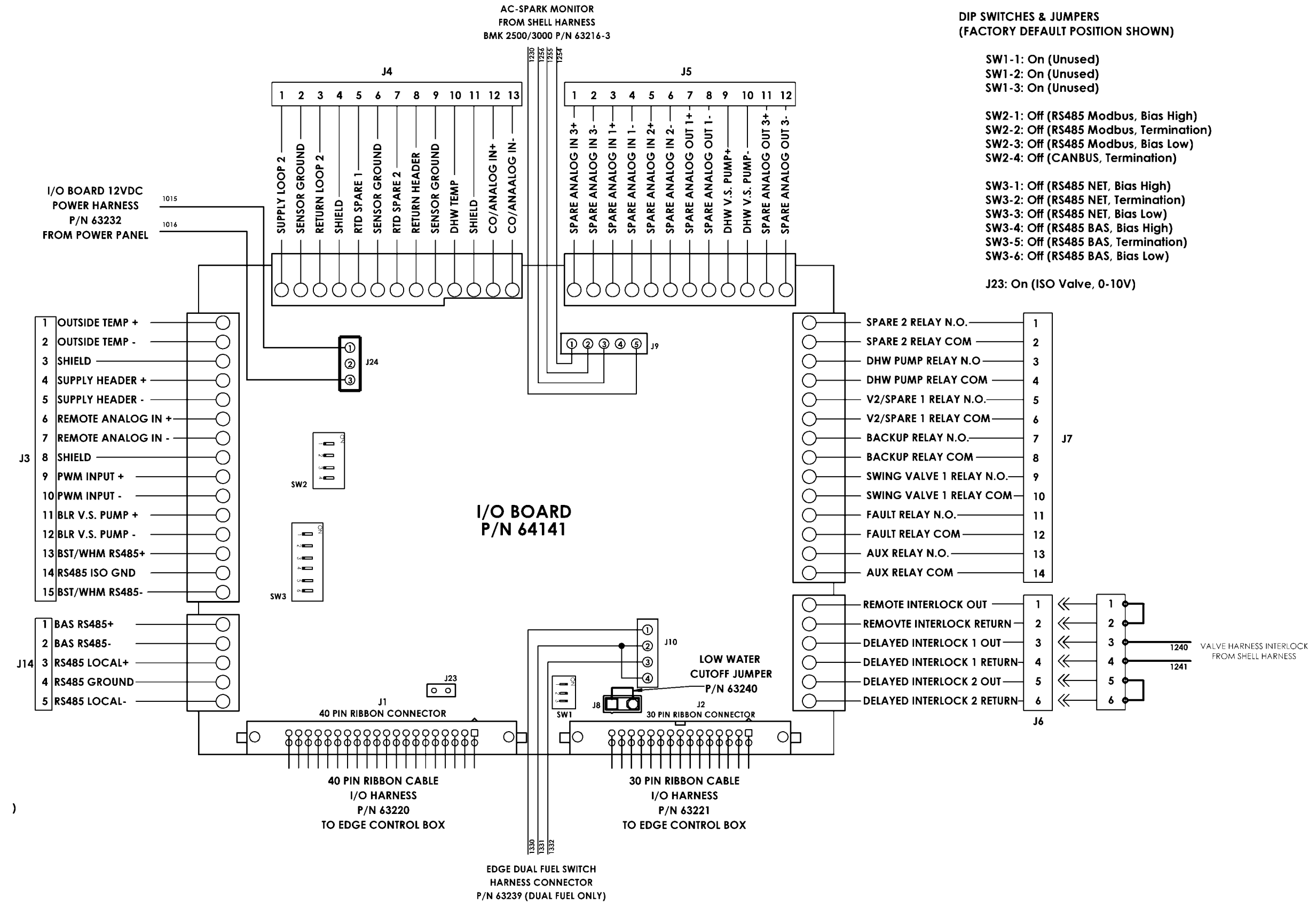

11.3 Benchmark 4000 – 5000N Schematics

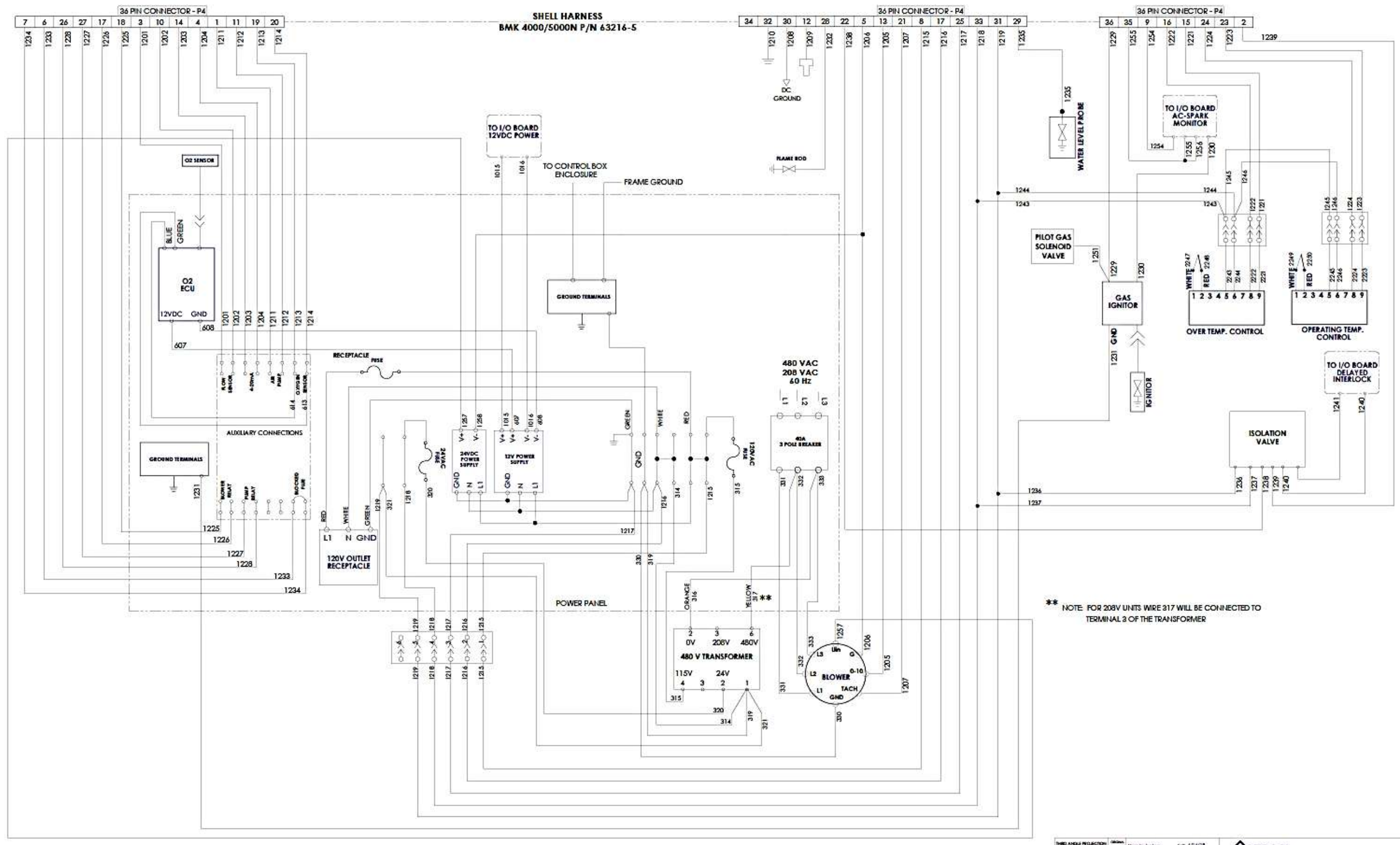

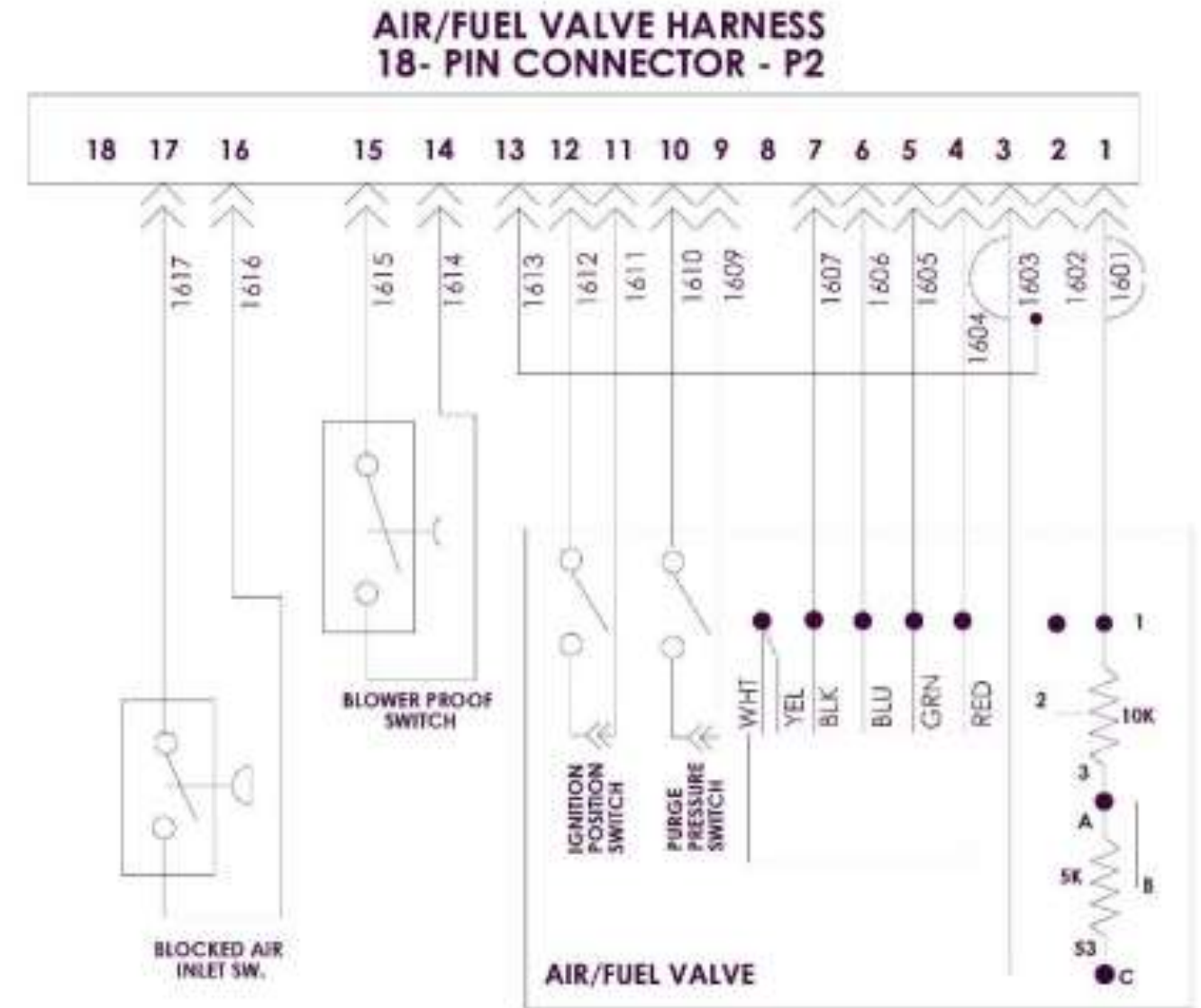
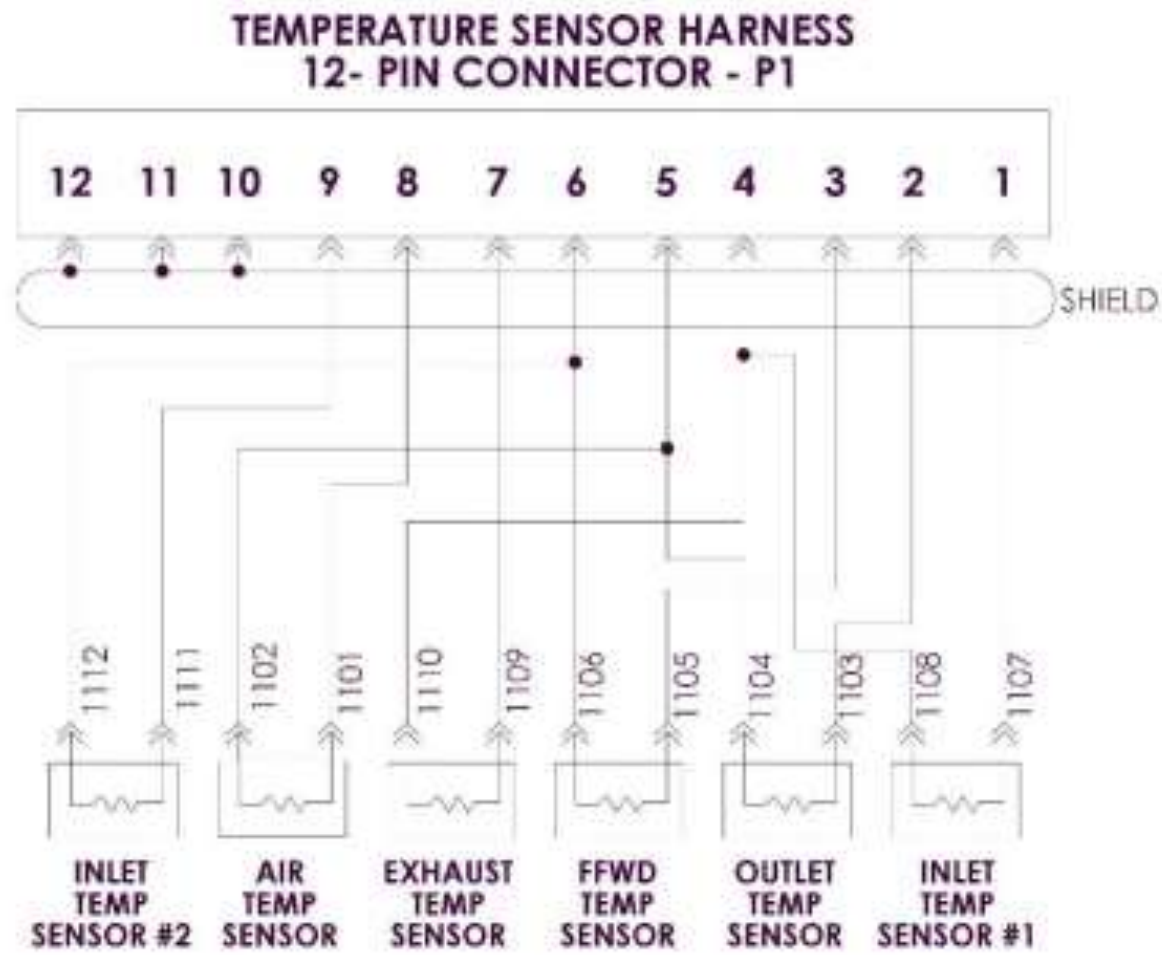

Benchmark 4000 – 5000N – Drawing Number: 68101 rev C Sheet 2 of 6

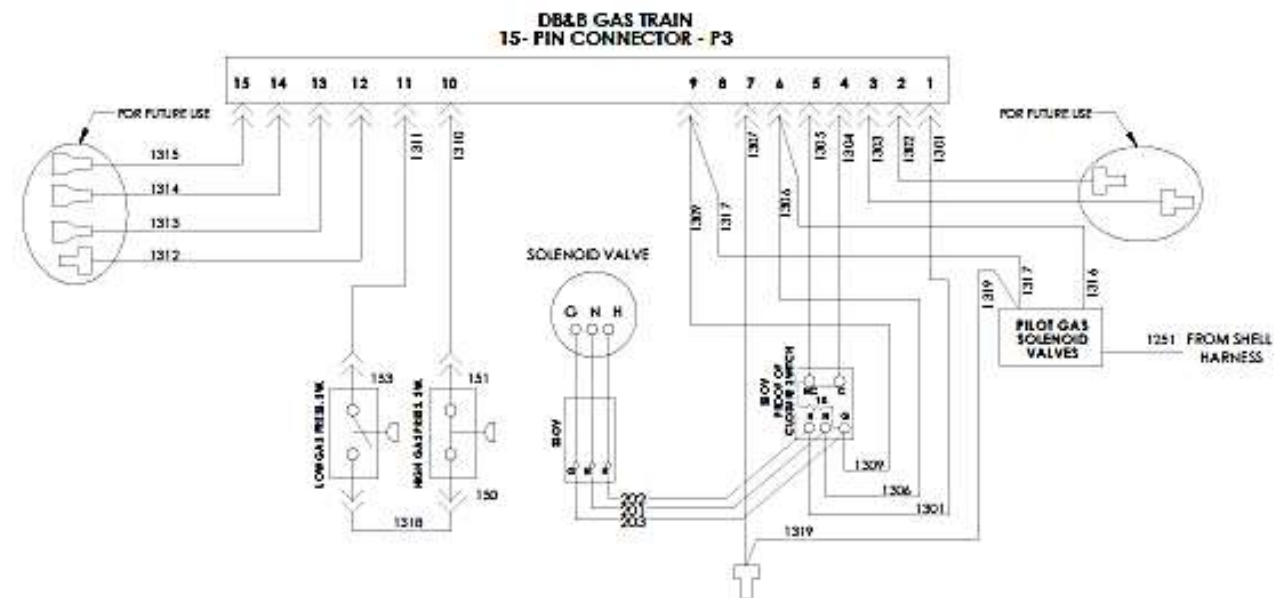
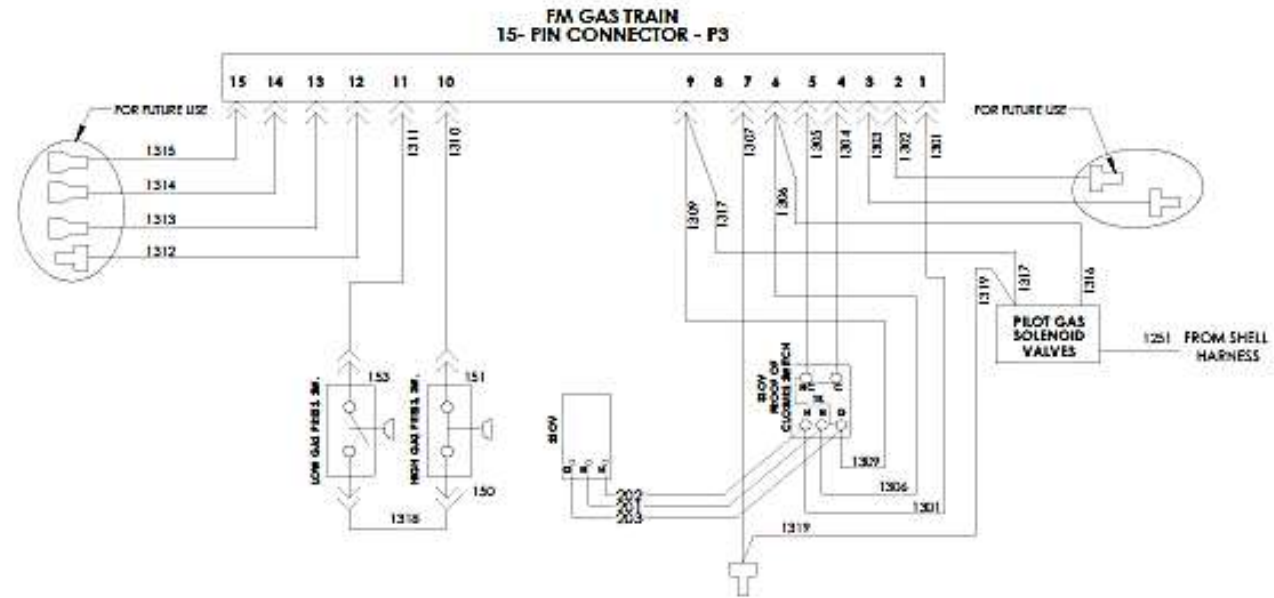

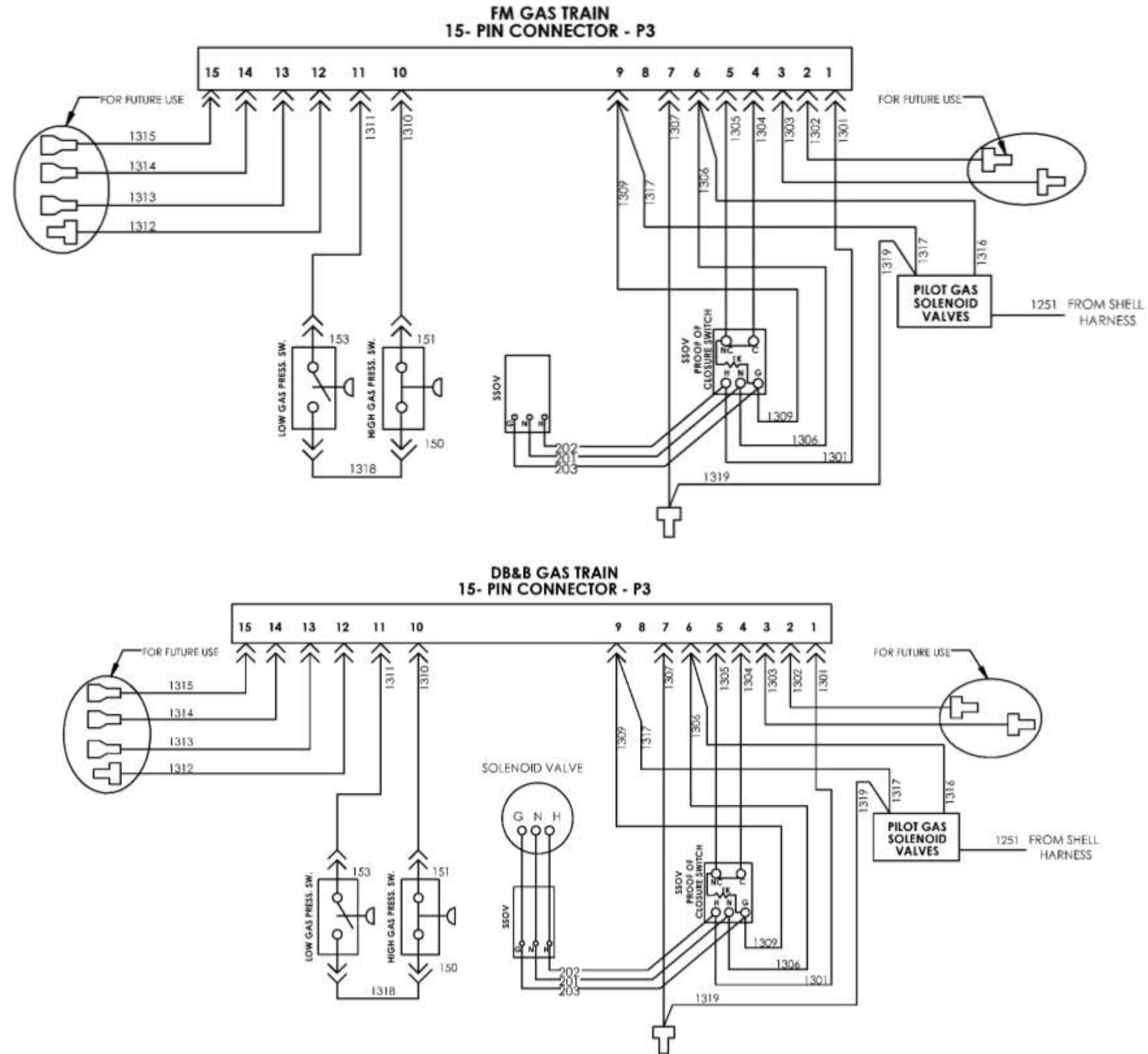

Benchmark 4000 – 5000N – Drawing Number: 68101 rev C Sheet 3 of 6

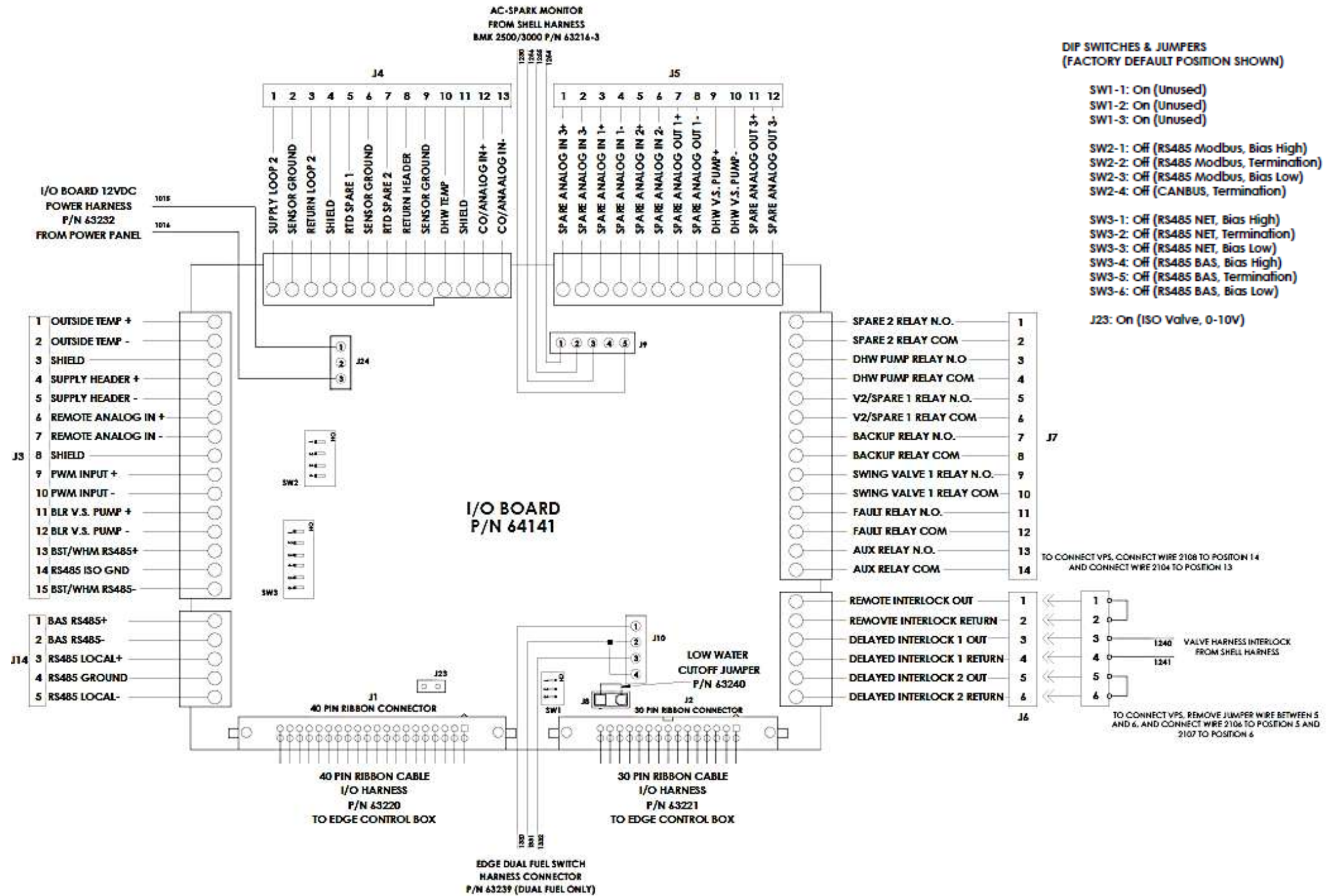

Benchmark 4000 – 5000N – Drawing Number: 68101 rev C Sheet 4 of 6

DUAL FUEL GAS TRAIN

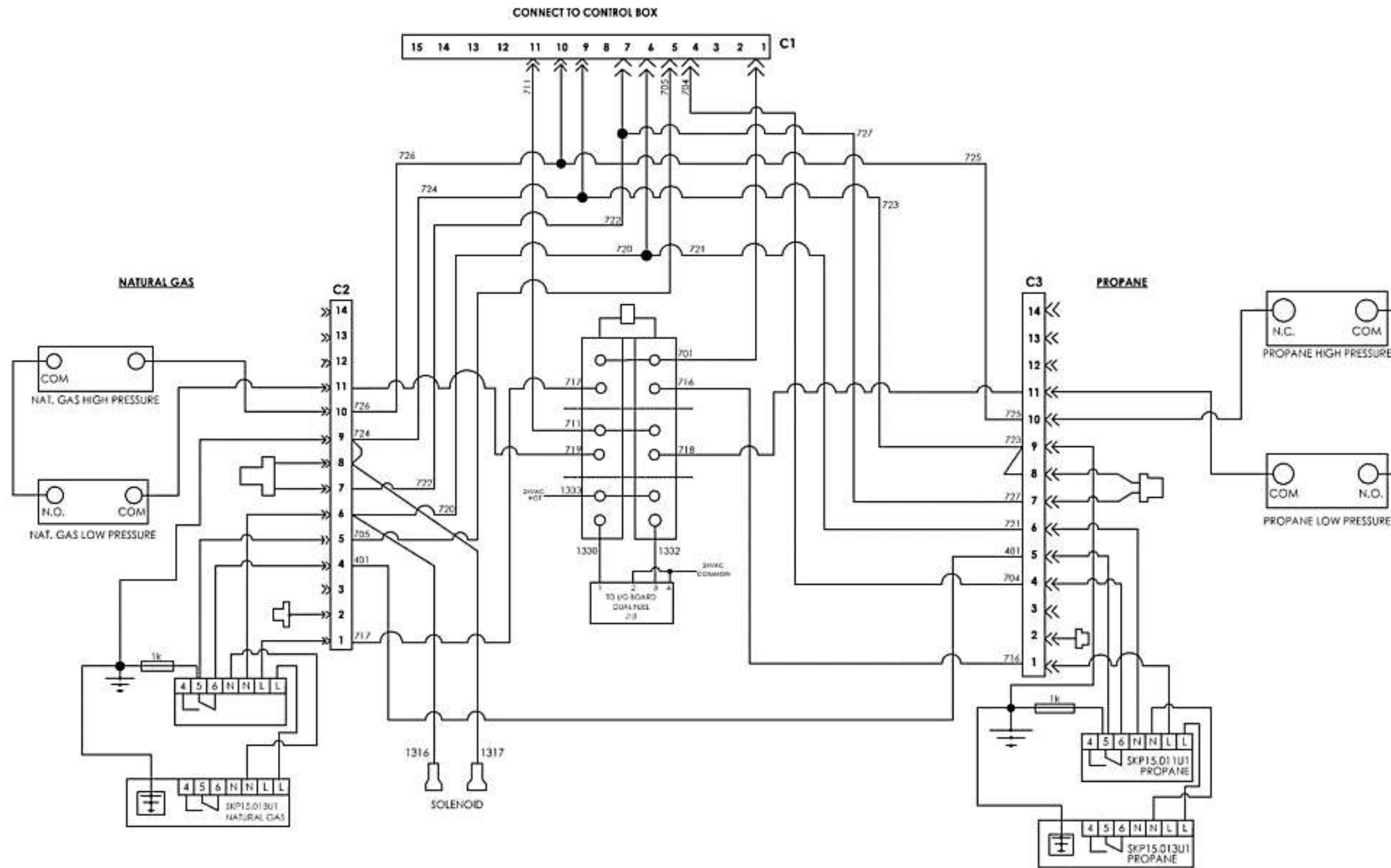

Benchmark 4000 – 5000N – Drawing Number: 68101 rev C Sheet 5 of 6

DUAL FUEL DOUBLE BLOCK AND BLEED GAS TRAIN

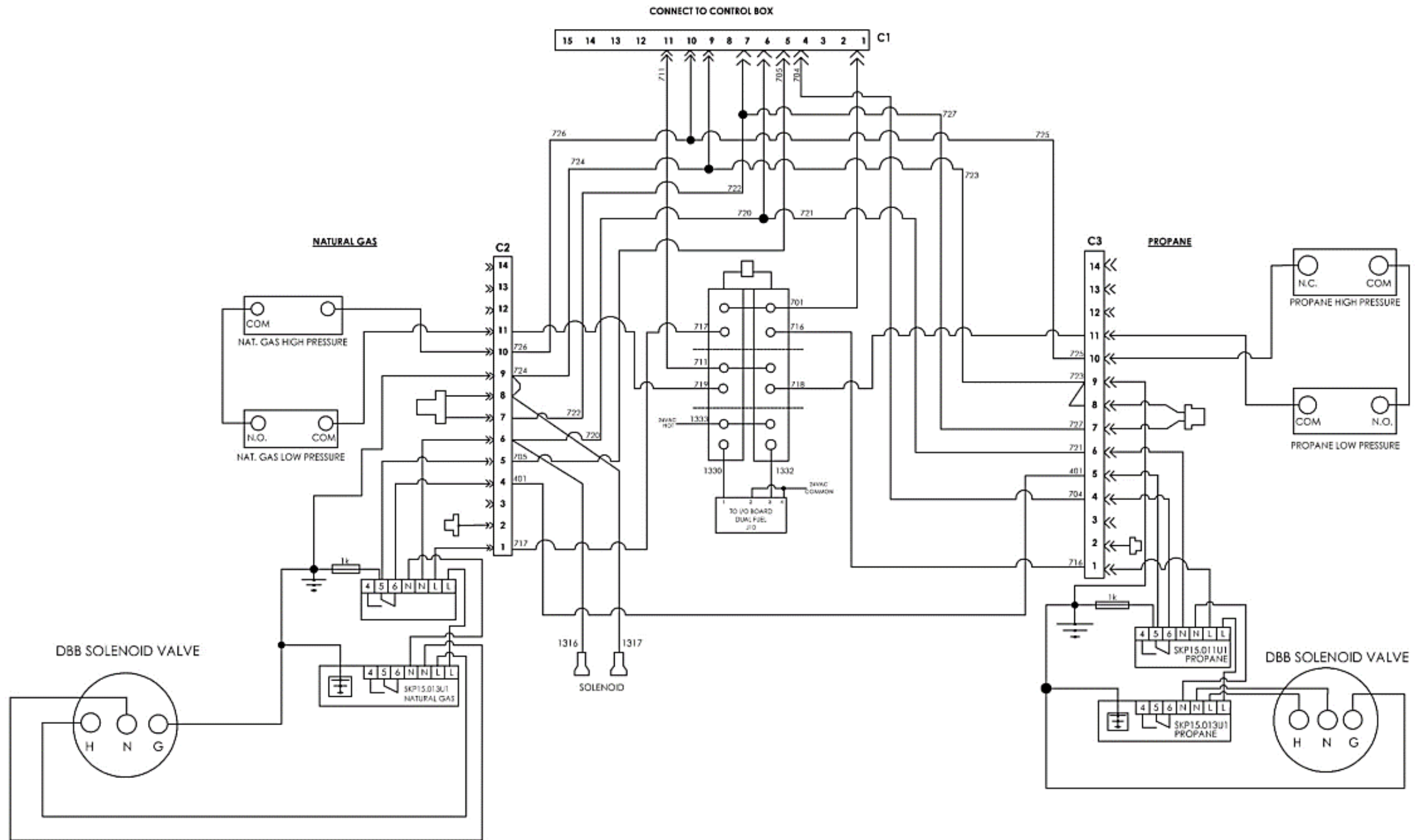

Benchmark 4000 – 5000N – Drawing Number: 68101 rev C Sheet 6 of 6

11.4 Benchmark 5000 – 6000 Schematics

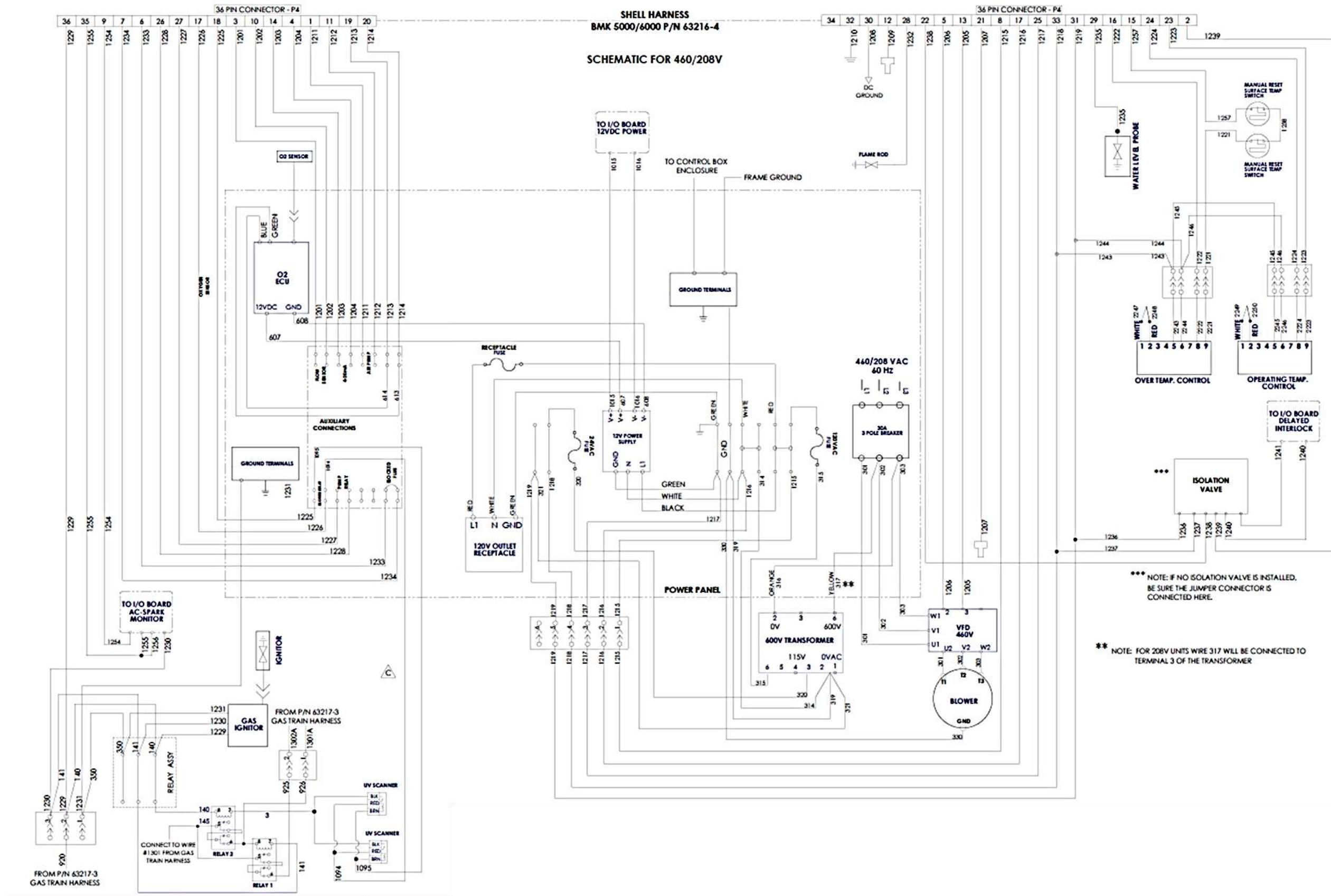

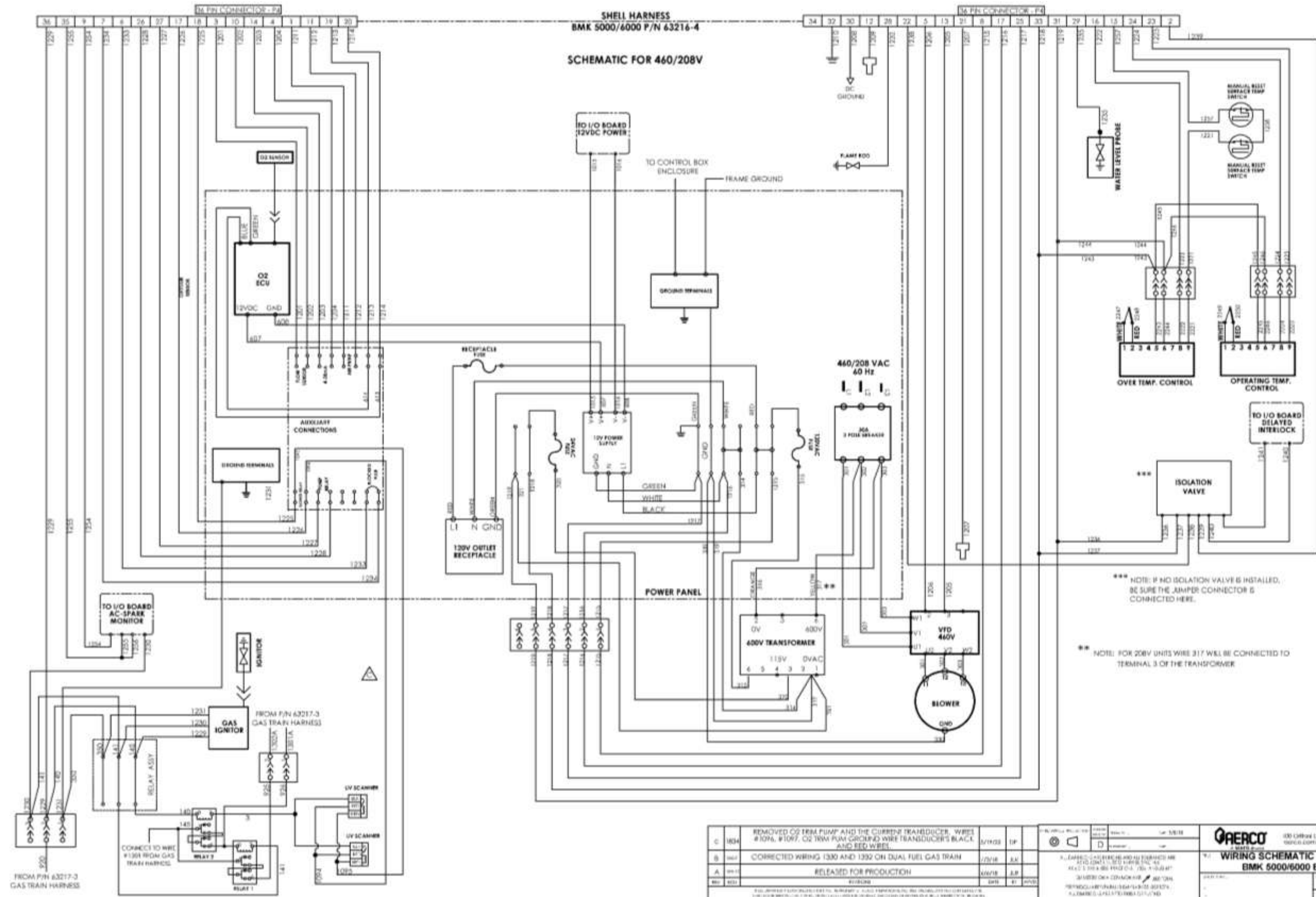

Benchmark 5000 – 6000 Drawing Number: 68096 rev B Sheet 1 of 4

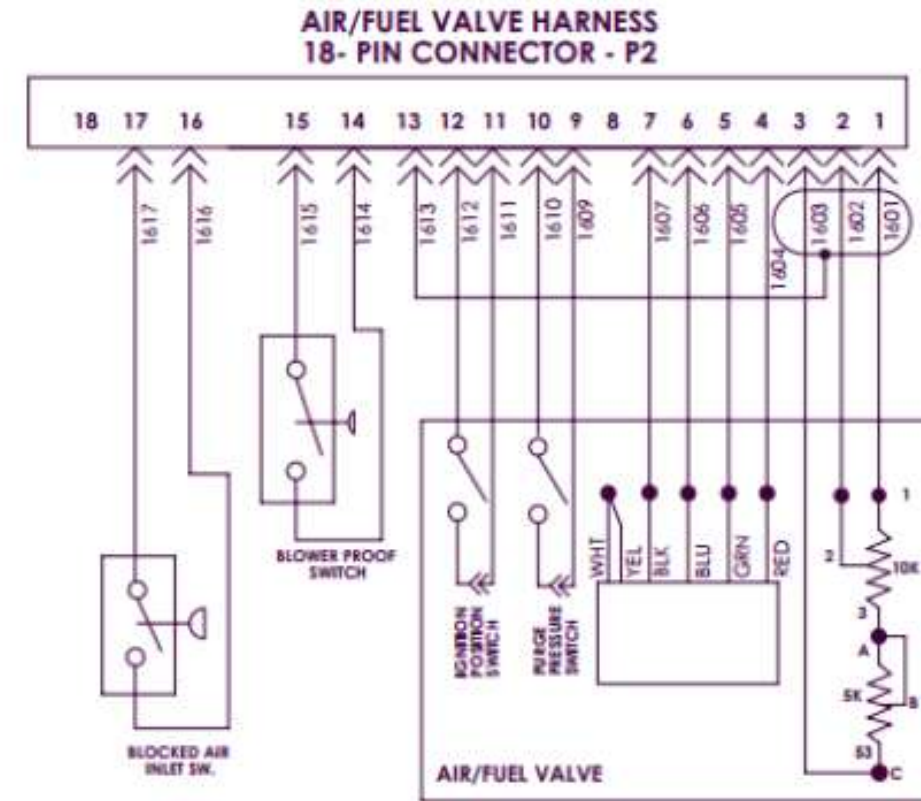
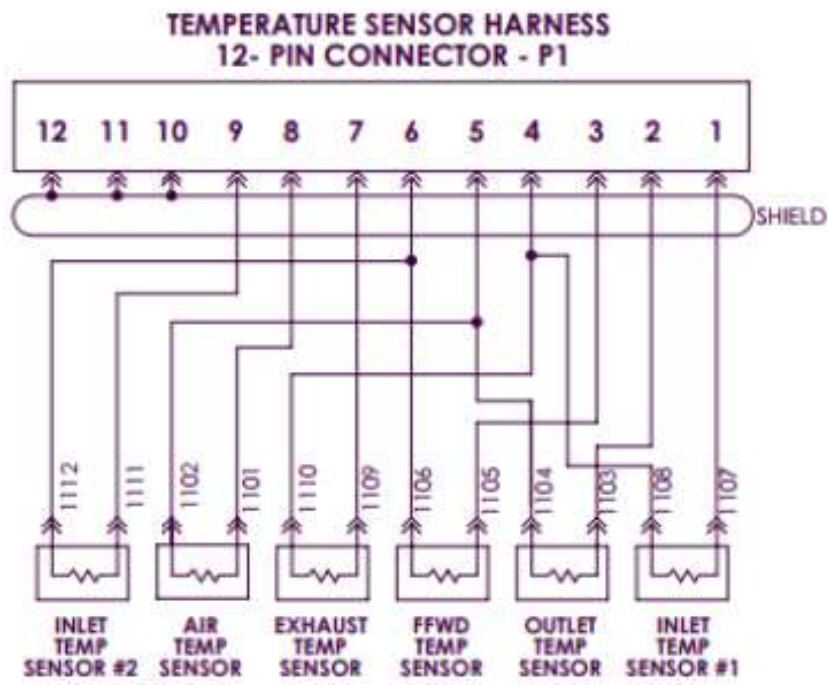

WIRING FOR VFD

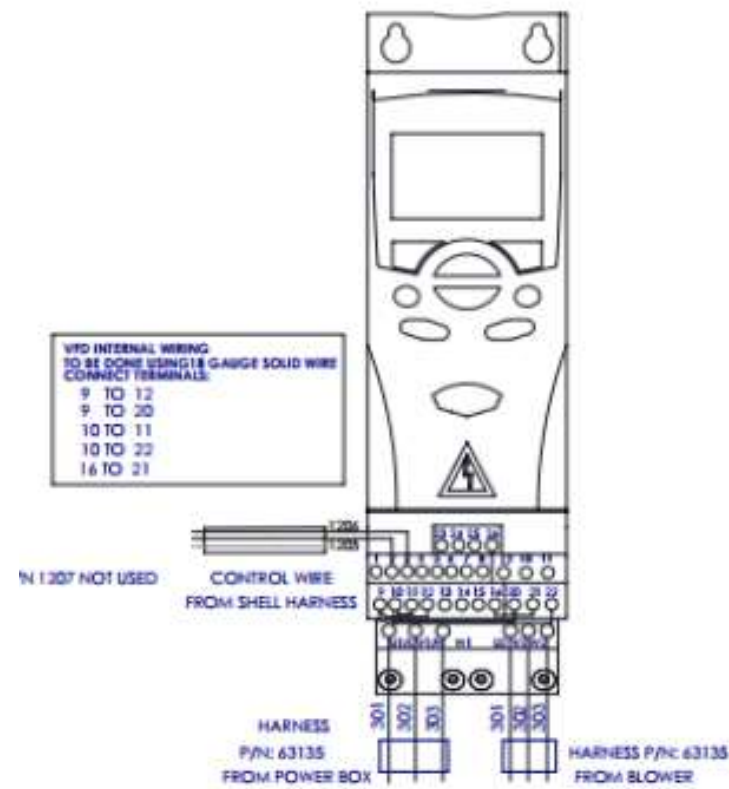

Benchmark 5000 – 6000 Drawing Number: 68096 rev B Sheet 2 of 4

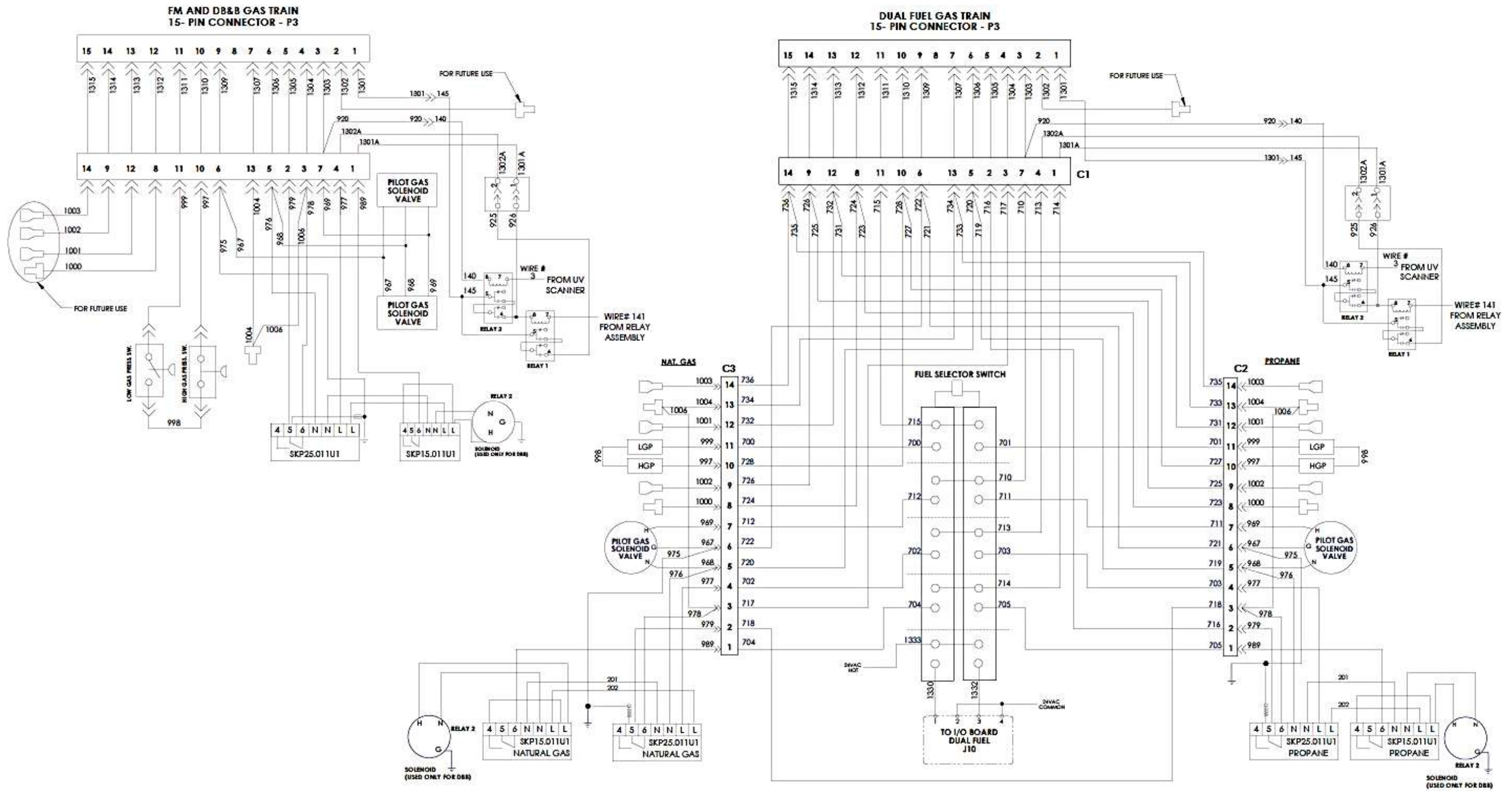

Benchmark 5000 – 6000 Drawing Number: 68096 rev B Sheet 3 of 4

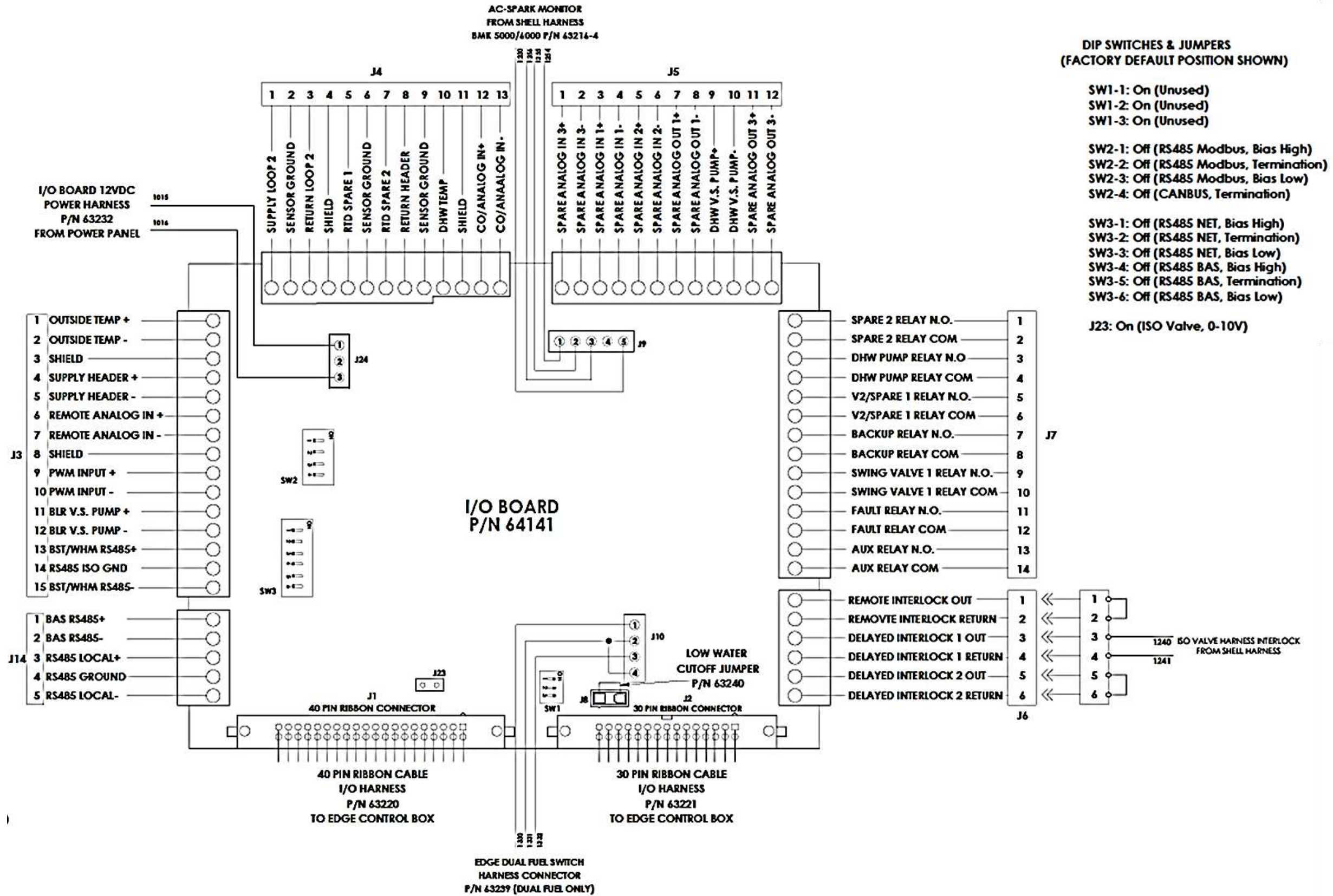

Benchmark 5000 – 6000 – Drawing Number: 68096 rev B Sheet 4 of 4

ok gthatf

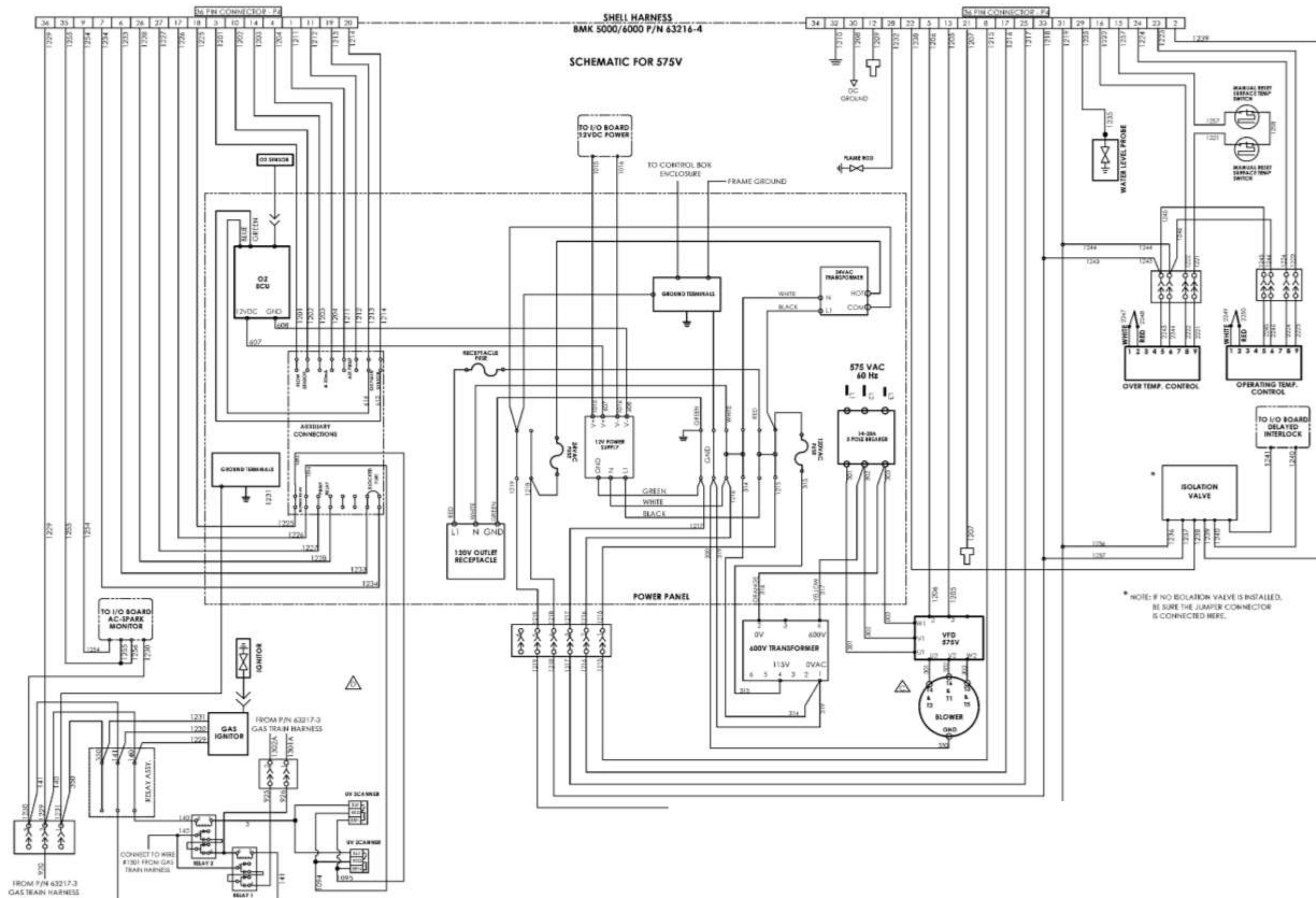

Benchmark 5000 – 6000 575V – Drawing Number: 68097 rev B Sheet 1 of 4

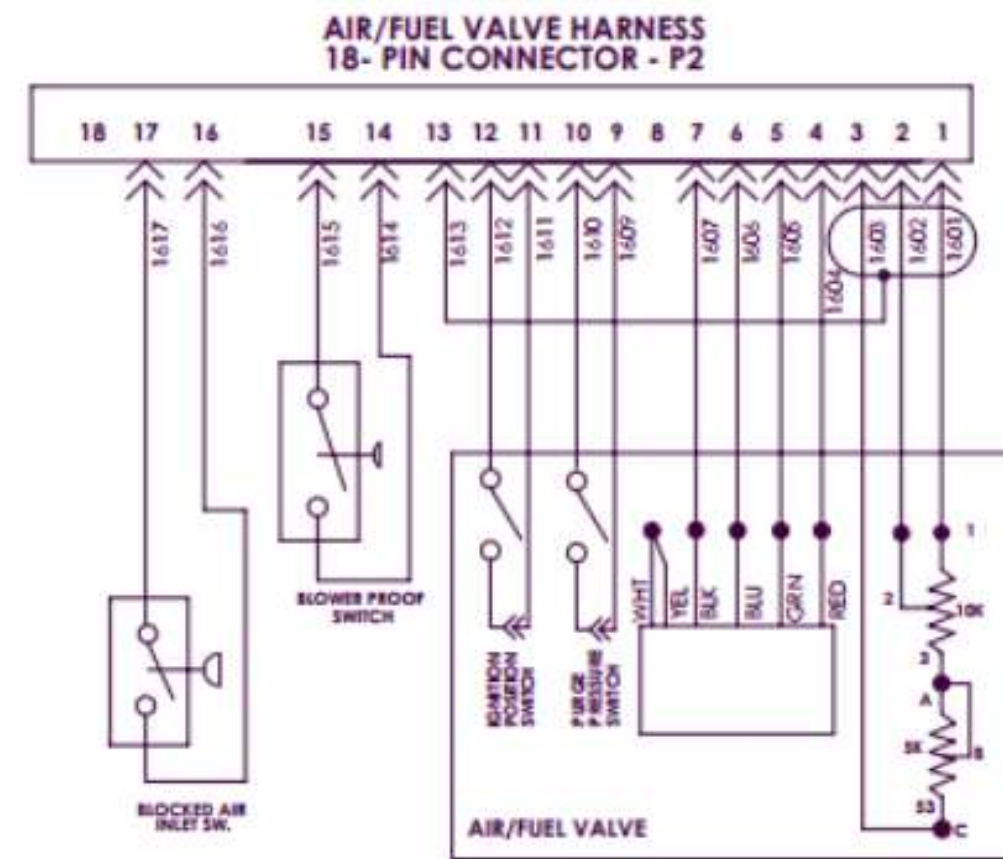
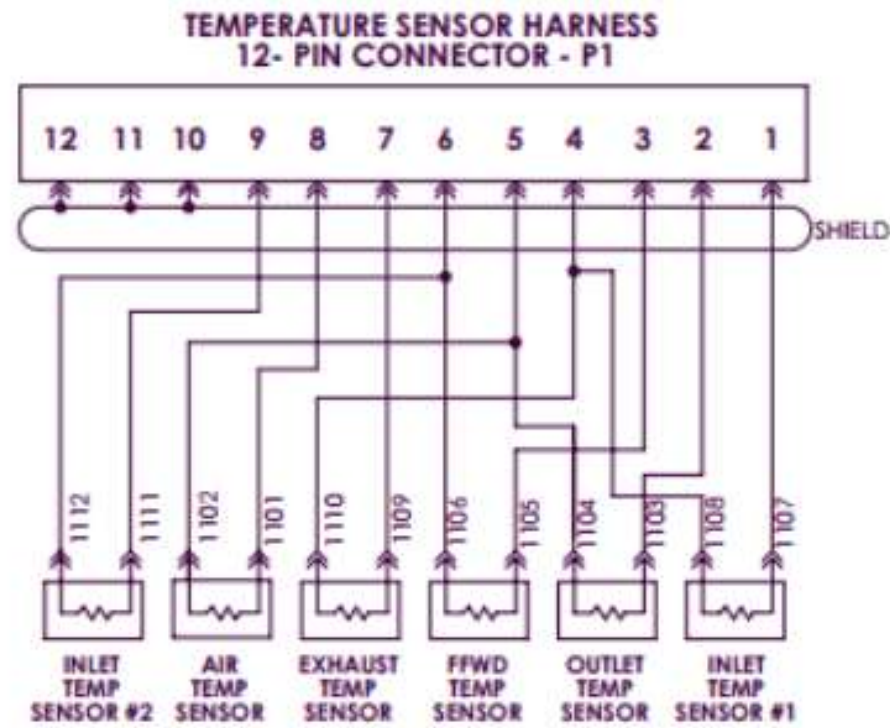

VFD INTERNAL WIRING
575V

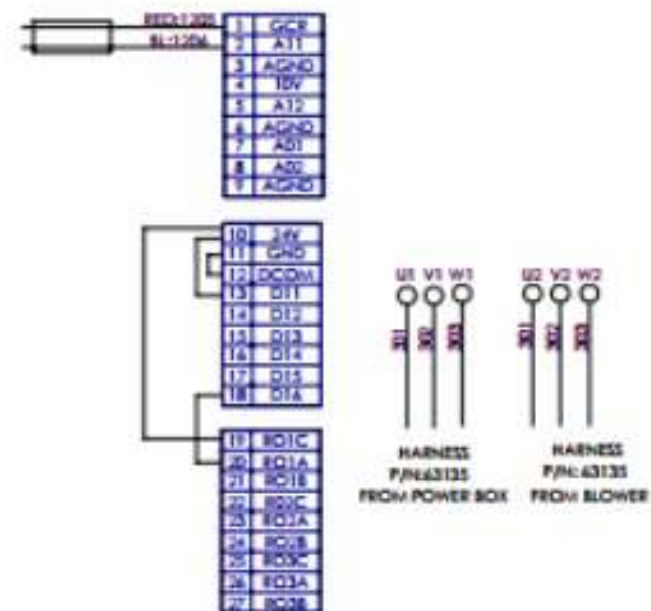

Benchmark 5000 – 6000 575V – Drawing Number: 68097 rev B Sheet 2 of 4

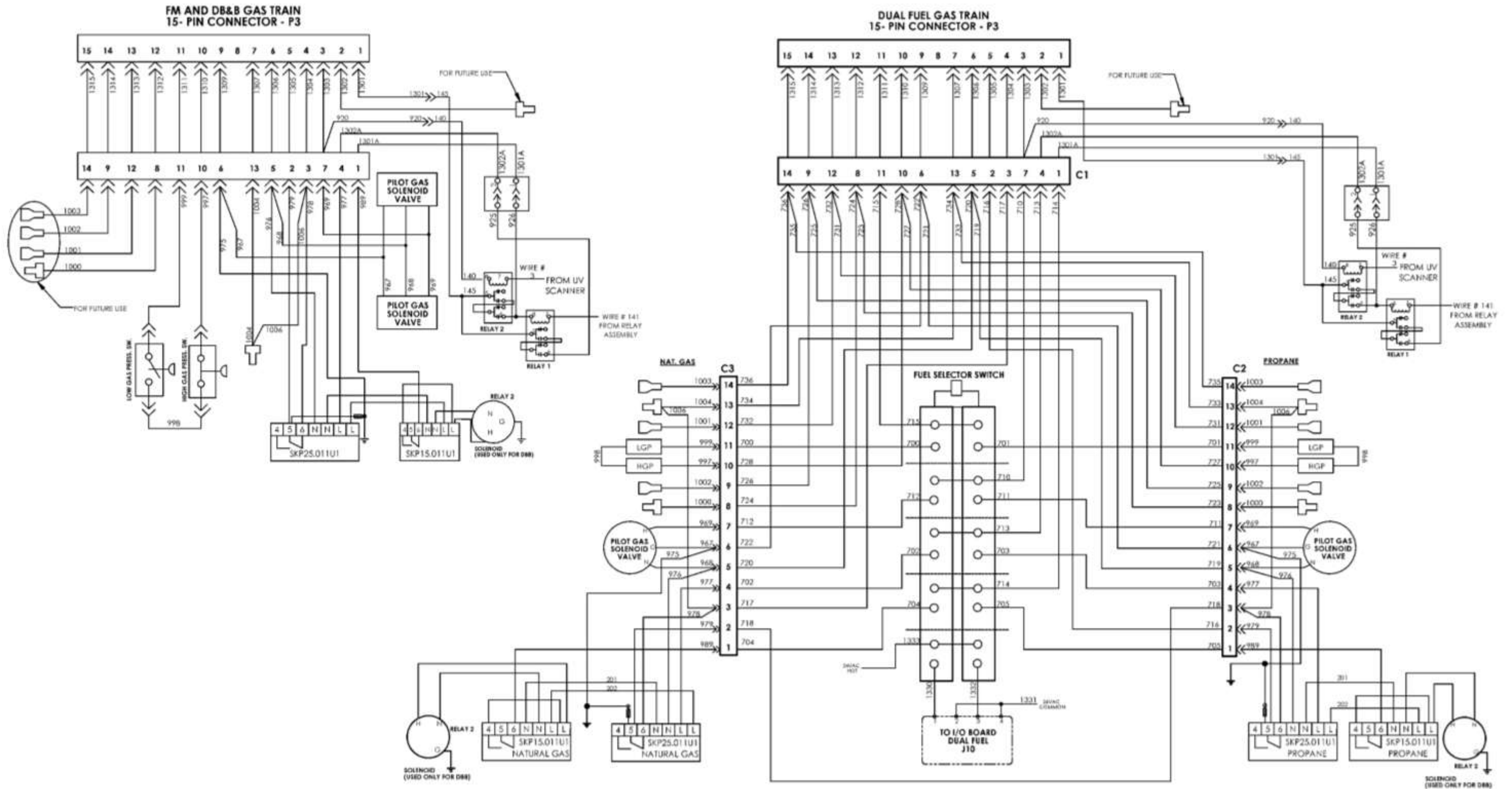

Benchmark 5000 – 6000 575V – Drawing Number: 68097 rev B Sheet 3 of 4

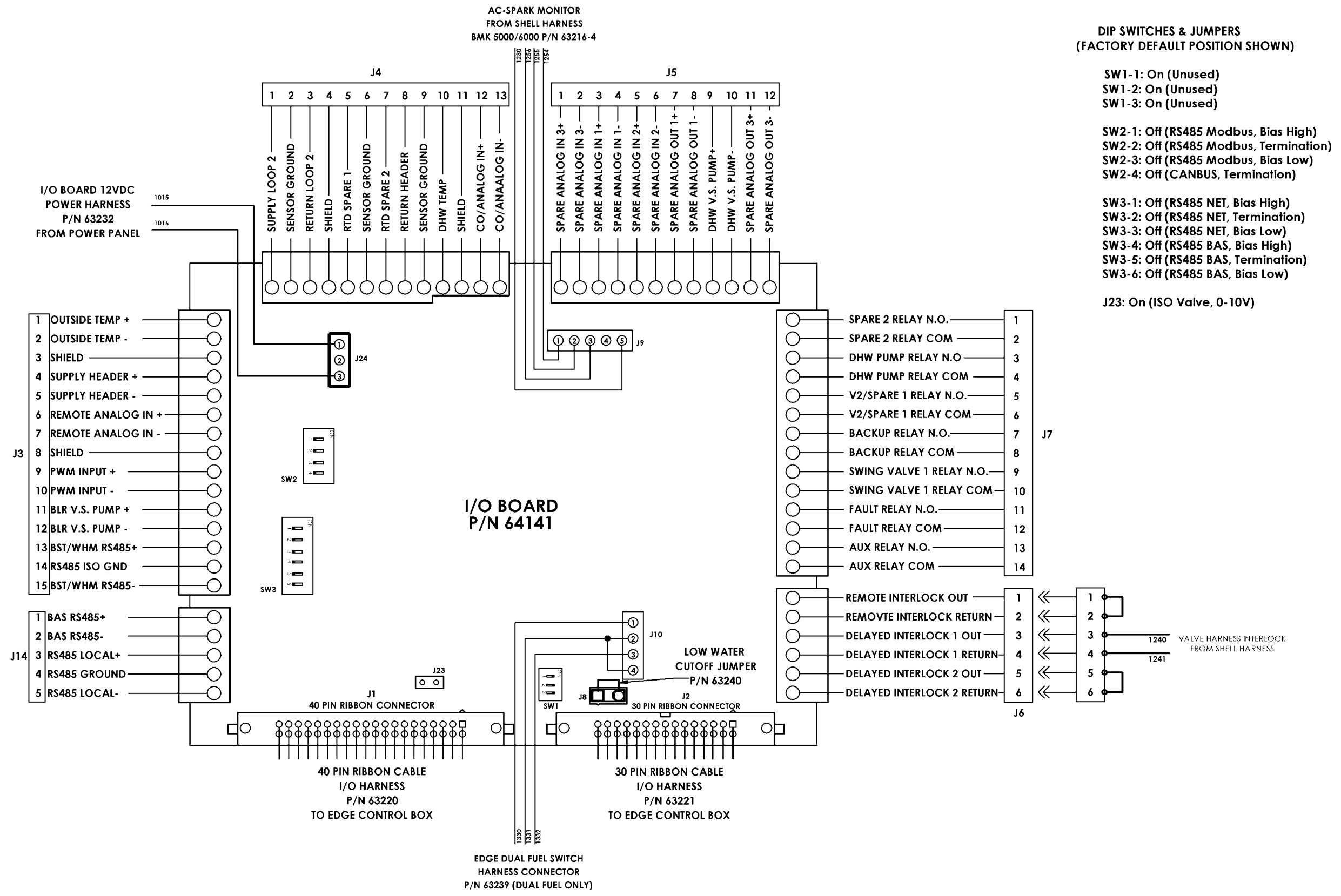

Benchmark 5000 – 6000 575V – Drawing Number: 68097 rev B Sheet 4 of 4



© AERCO International, Inc., 2026